

---

# **BETA** MARINE

---

## **Operator's Maintenance Manual**

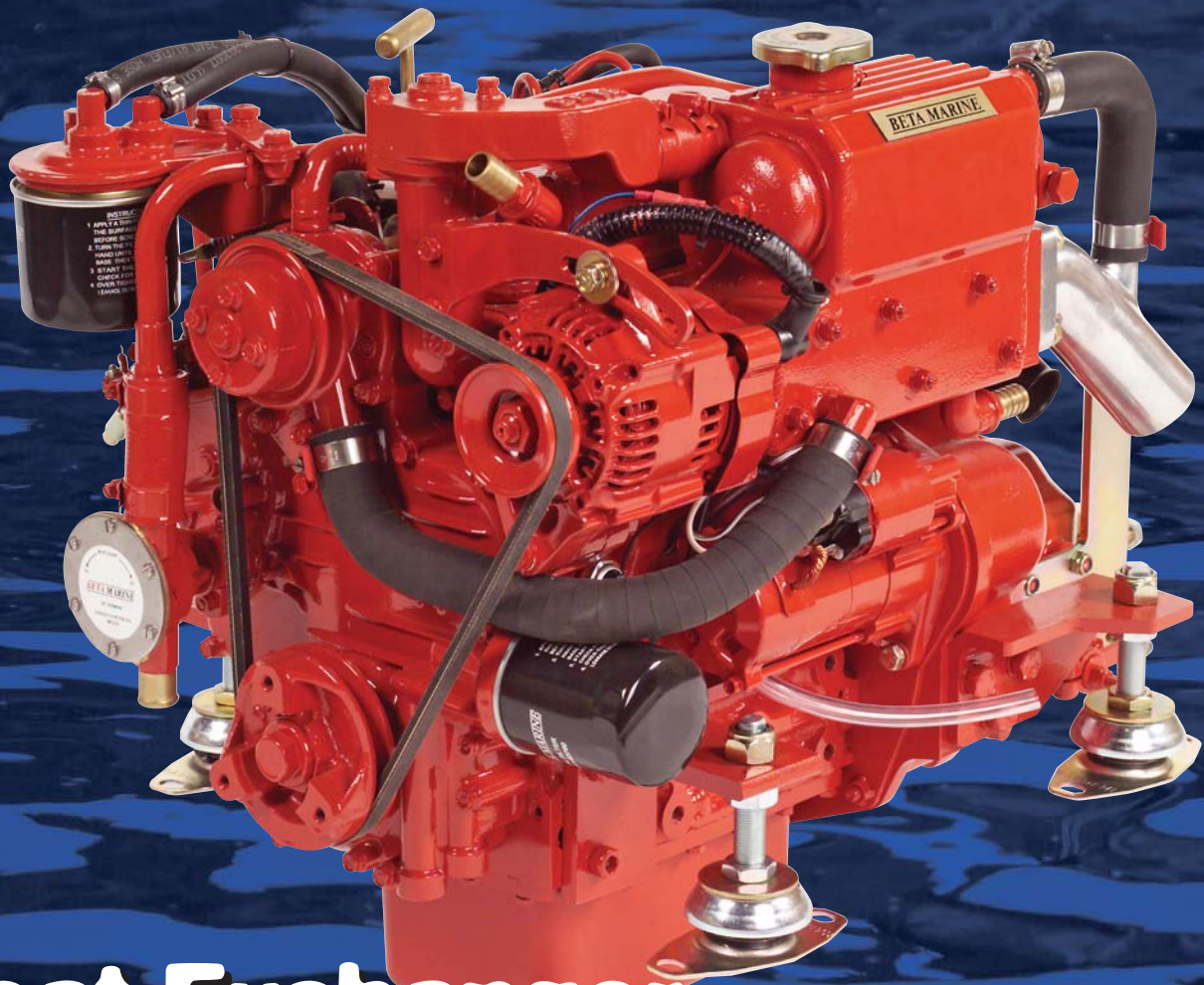

### **Heat Exchanger & Keel Cooled**

**Small Diesel Engine Range: Beta 10,  
Beta 14, Beta 16, Beta 20 & Beta 25**

CALIFORNIA — Proposition 65 Warning: Diesel engine exhaust and some of its constituents are known to the state of California to cause cancer, birth defects and other reproductive harm.

# Engine Details

IMPORTANT - Please fill in details at moment of purchase - it really will help you! (and it will really help us specify the correct spare parts for you).

Engine Type:	Power:	bhp	Speed:	rpm
BETA WOC NO:                      K				
Gearbox Type:				
Purchased From:				
Invoice No.:				
Date Commissioned:				
Specification / Special Details:				



# Contents

<b>My engine details</b> (to be completed now)	Inside front cover
<b>Introduction</b>	
Engine identification	2
Initial receipt of the engine	2
Engine storage	2
<b>Safety precautions</b>	<b>3</b>
<b>Technical specifications</b>	<b>4</b>
<b>Section 1: Installation guidelines</b>	
Engine mounting	5
Engine alignment - drives, flanges, flexible couplings	6
Exhausts and mounting exhausts	7 & 8
Fuel supply and "leak off"	9
Cooling - sea water inlet system	10
Cooling - keel cooling system	10 & 11
Calorifier connections (if fitted)	12
Electrical Installation	13
<b>Section 2: Guidelines for operation of the engine</b>	
<b>Important checks prior to initial use</b>	<b>14</b>
<b>Initial start-up and bleeding the fuel system</b>	<b>14</b>
<b>Starting and stopping</b>	<b>15 &amp; 16</b>
<b>Section 3: Maintenance &amp; Service guidelines</b>	
Maintenance schedule	17 & 18
Lubrication - checking and changing oil	19 & 20
Fuel system - fuel/water separator, fuel lift pump, fuel filter	21
Cooling - fresh water system, heat exchanger	22
Sea water pump, heat exchanger	24
Belt tensioning adjustment	25
Air filter inspection / replacement	25
Electrical maintenance	26
Laying up - winterising	26
<b>Troubleshooting</b>	<b>28</b>
<b>Torque settings</b>	<b>39</b>
<b>Wiring diagrams and general arrangement drawings index</b>	<b>40</b>
<b>Exhaust Emission - Declaration of Conformity</b>	<b>71 &amp; 72</b>
<b>Exhaust Emission - Durability</b>	<b>73</b>
<b>Fast Moving Parts Listing</b>	<b>76, 75 &amp; 74</b>
<b>Maintenance record</b>	Inside back cover

# OPERATION AND MAINTENANCE MANUAL FOR THE FOLLOWING BETA MARINE ENGINES BASED ON KUBOTA MINI SERIES

## Beta 10, Beta 14, Beta 16, Beta 20 & Beta 25

This manual has been compiled to provide the user with important information and recommendations to ensure trouble free and economical operation of the engine.

As manufacturers we have obviously written this "Operators Maintenance Manual" from our 'involved technical viewpoint' assuming a certain amount of understanding of marine engineering. We wish to help you, so if you do not fully understand any phrase or terminology or require any explanations please contact Beta Marine Limited or its distributors and we will be pleased to provide further advice or technical assistance.

All information and recommendations given in this publication are based on the latest information available at the time of publication, and are subject to alteration at any time.

The information given is subject to the company's current conditions of Tender and Sale, is for the assistance of users, and is based upon results obtained from tests carried out at the place of manufacture and in vessels used for development purposes. We do not guarantee the same results will be obtained elsewhere under different conditions.

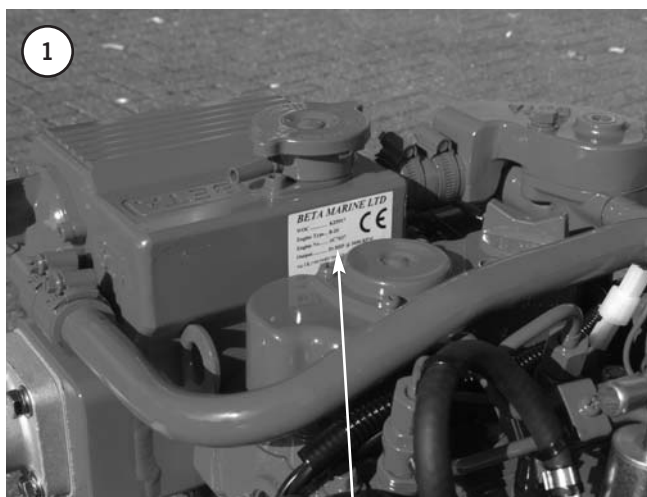

### Engine Identification

**NOTE:** In all communications with the distributor or Beta Marine, **the W.O.C. and engine number must be quoted.**

### Beta 10, Beta 14, Beta 16, Beta 20 and Beta 25

The engine serial number is stamped above the fuel lift pump on the starboard side of the engine, and is shown on the rocker cover label.

### 2 **BETA MARINE LTD**

WOC..... K12345

Engine Type... Beta 20

Engine No..... 1Z1234

Output.....20 BHP @ 3600 RPM

Tel: UK (44) 01452 723492 Fax: UK (44) 01452 883742

Email: sales@betamarine.co.uk

(Quote WOC number for spares)

### Initial Receipt of the Engine

A full inspection of the engine must be made **immediately on delivery** to confirm that there is no damage. If there is any damage then write this clearly on the delivery note and inform your dealer or Beta Marine within 24 hours. A photograph would always help.

### Engine Storage

The engine must be stored in a dry, frost free area and this is best done in its packing case. If storage is to be more than six months then the engine must be inhibited (contact your dealer or Beta Marine). Failure to inhibit the engine may result in the formation of rust in the injection system and the engine bores, this could invalidate the warranty.

# Safety Precautions!

**A Keep the engine, gearbox and surrounding area clean, including the area immediately below the engine**

## **B Drives - Power Take Off Areas**

**i) Gearbox Output Flange **

The purpose of a marine diesel propulsion engine is to provide motive power to propel a vessel. Accordingly the gearbox output shaft rotates at between 280 and 2400 rev/min. This flange is designed to be coupled to a propeller shaft by the installer and steps must be taken to ensure adequate guarding.

**ii) Forward End Drive **

Engines are supplied with unguarded belt drives to power the fresh water pump and battery charging alternator. The installer must ensure that it is not possible for injury to occur by allowing access to this area of the engine. The three pulleys run at high speed and can cause injury if personnel or clothing come in contact with the belts or pulleys, when the engine is running.

**iii) Power Take Off Shaft ** (Engine Mounted Option)

Shaft extensions are available as an option and rotate at between 850 and 3600 rev/min. If contact is made with this shaft when the engine is running, injury can occur.

## **C Exhaust Outlet**

Diesel marine propulsion engines emit exhaust gases at very high temperatures - around 400 - 500°C. Engines are supplied with either wet exhaust outlet (water injection bend) or dry outlet (dry exhaust stub) - see option list. At the outlet next to the heat exchanger / header tank, the exhaust outlet can become very hot and if touched, can injure. This must be lagged or avoided by ensuring adequate guarding. It is the responsibility of the installer to lag the exhaust system if a dry system is used. Exhaust gases are harmful if ingested, the installer must therefore ensure that exhaust lines are led overboard and that leakage in the vessel does not occur.

## **D Fuel**

**i) Fuel Lines **

Diesel engines are equipped with high pressure fuel injection pumps, if leakages occur, or if pipes fracture, fuel at a high pressure can harm personnel. Skin must be thoroughly cleaned in the event of contact with diesel fuel.

**ii) Fuel Supply Connections **

Engines are supplied with 8mm compression fittings. The installer must ensure that when connections are made, they are clean and free of leaks.

## **E Oil**

The Beta propulsion unit is supplied with 2 dipsticks, one for the engine and one for the gearbox. Ensure dipsticks are returned and secure after checking, if not oil leaks can cause infection when touched. All oil must be removed from the skin to prevent infection.

## **F Scalding**

An engine running under load will have a closed circuit fresh water temperature of 85° to 95°C. **The pressure cap on the top of the heat exchanger must not be removed when the engine is running.** It can only be removed when the engine is stopped and has cooled down.

## **G Transportation / Lifting**

Engines are supplied on transportable pallets. Lifting eyes on engines are used for lifting engine and gearbox assembly only, not the pallet and associated kit.

## **GENERAL DECLARATION**

This machinery is not intended to be put into service until it has been incorporated into or with other machinery. It is the responsibility of the purchaser / installer / owner, to ensure that the machinery is properly guarded and that all necessary health and safety requirements, in accordance with the laws of the relevant country, are met before it is put into service.

Signed:



J A Growcoot, C.E.O,  
Beta Marine Limited

### **NOTE: Recreational Craft**

Where applicable, the purchaser / installer / owner and operator must be responsible for making sure that the Recreational Craft Directive 94/25/EC is complied with.

# Technical Specifications

Standard Engines	Beta 10	Beta 14	Beta 16	Beta 20	Beta 25
Cylinder	2	2	2	3	3
Bore (mm)	67	67	72	67	72
Stroke (mm)	68.0	68.0	73.6	68.0	73.6
Displacement (cc)	479	479	599	719	898
Combustion	3 Vortex				
Cooling	Water				
Starter voltage (V)	12	12	12	12	12
Starter output (kW)	0.8	0.8	0.8	0.8	0.8
Starter alternator output (Amps)	40 (standard)				
Glow plug resistance (each)	1Ω	1Ω	1Ω	1Ω	1Ω
Engine speed (RPM) at full load	3,000	3,600	3,600	3,600	3,600
Power output to ISO3046 (BHP)	10.0	13.3	16.7	20.0	24.8
Declared power ISO8665 (kW)	7.4	8.7	11.0	13.1	16.3
Compression Ratio	23.0:1	23.0:1	23.0:1	23.0:1	23.0:1
Fuel timing BTDC	21°	21°	21°	21°	21°
Capacity of standard sump approx. (litres)	2.0 - 2.5	2.0 - 2.5	2.4 - 2.9	3.1 - 3.8	3.7 - 4.5
Capacity of shallow sump approx. (litres)	2.2	2.2	2.6	3.4	3.8
Nett dry weight with gearbox (kg)	89	90	95	104	113
Fuel	Diesel fuel oil A1 / A2				
Coolant	33%-50% maximum antifreeze:water				
Coolant capacity approx.. (H/E litres)	2.25	2.25	2.25	3.00	3.25
Min. recommended battery capacity	12V, 40Ah	12V, 40Ah	12V, 40Ah	12V, 75Ah	12V, 75Ah

**Maximum Angle of Installation:** Maximum 15° flywheel up or flywheel down when static; or up to 25° when heeling.

**Rotation:** Anti-clockwise on flywheel, clockwise on output gearbox flange for use with right hand propeller in ahead, on mechanical gearboxes. Hydraulic gearboxes can be left or right handed. Diesel fuel must conform to BS2869-1970 class A1 or A2. The fuel must be a distillate and not a residual oil or blend.

**Lubricant:**

Engine - engine oil must meet API Classification CF (CD or CE), See section 2 for details

Gearbox - see gearbox operator's manual for the gearbox oil type and capacity

Oil pressure - minimum (tickover) 0.5 bar

**Power outputs:** These comply with BS EN ISO 8665:1996 crankshaft power

**Note:** Declared Powers to ISO8665:1996

1. The declared powers are at the same engine speed as the ISO 3046 figures. This speed is the speed related to the outputs / powers shown.
2. Declared powers are at the gearbox coupling (coupling to the propeller shaft) as per EN ISO 8665:1995 clause 3.2.1 with standard specifications as per our current price lists. Additional accessories or alternative gearboxes may affect the declared powers.
3. Operation at parameters outside the test parameters may affect the outputs / powers which in any case are subject to the ISO tolerance bands.

# Section 1

## Installation Recommendations

The installation details are basic guidelines to assist installation, however due to the great diversity of marine craft it is impossible to give definitive instructions. Therefore Beta Marine can accept no responsibility for any damage or injury incurred during the installation of a Beta Marine Engine whilst following these guidelines.

- All engines shall be placed within an enclosure separated from living quarters and installed so as to minimise the risk of fires or spread of fires as well as hazards from toxic fumes, heat, noise or vibrations in the living quarters.
- Unless the engine is protected by a cover or its own enclosure, exposed moving or hot parts of the engine that could cause personal injury must be effectively shielded.
- Engine parts and accessories that require frequent inspection and / or servicing must be readily accessible.
- The insulating materials inside engine spaces shall be non-combustible.
- **Ventilation** - It is important that the engine compartment has adequate ventilation, and this is your responsibility. If there is no ventilation the engine can overheat and damage can be caused. As a general statement an engine will produce radiated heat - approximately equal to  $\frac{1}{3}$  of the engine output power. Also the 45 & 100 amp battery charging alternators create lots of heat. (A symptom of overheating problems is often black belt dust).

If you have any doubts about the temperature of your engine compartment please check with a thermometer on a hot day, the maximum temperature in the engine compartment should be less than 60°C - the cooler the better! Engine compartment ventilation is normally best with two holes; **an inlet** allowing colder air to enter near to the alternator and drive belts and a **second outlet** (a third bigger than the inlet) for the hot air to rise and ventilate out from the top of the engine compartment. Adequate ventilation must be included with all installations.

- **General - Keel Cooled Engines**, sometimes overheating is caused by:
  - (a) Not fully venting the engine cooling system of air. It is necessary to remove all air from the cooling system - including the "skin" tanks and (if fitted) the Calorifier and associated piping.
  - (b) Incorrectly sized "skin" tanks that have been sized for 'usual' canal use, rather than maximum engine output that can sometimes be required on fast flowing rivers. An additional "skin" tank may need to be fitted; please refer to our website.

## Engine Mounting

To ensure vibration free operation, the engine must be installed and correctly aligned on substantial beds, extending as far forward and aft as possible, well braced and securely fastened to form an integral part of the hull.

The engine must be installed as low as possible on the flexible mount pillar stud. This will limit vibration and extend the life of the flexible mount. To assist with engine replacement we offer 'Special Engine Feet' manufactured to your dimensions, as an optional extra to suit your existing engine bearers and shaft alignment/installation.

### Warning

- (1) Do not set the engine feet high up the flexible mount pillar stud. This will cause excessive engine movement and vibration. Pack under the flexible mount with steel shims securely bolted into the engine bearer.

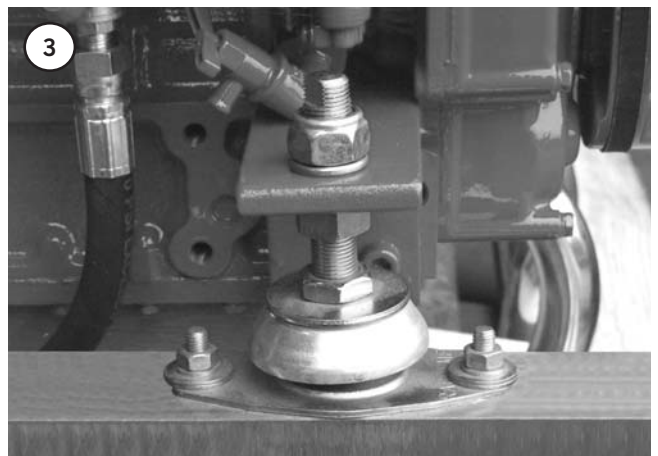

- (2) The pillar stud on the flexible mount is secured into position by the lower locknut, do not forget to tighten this. **Also ensure that the stud is not screwed too far through the mounting body so that it can touch the bearer. This will cause vibration and knocking noises which are very hard to find!**

## Engine Installation at an Angle

Beta Marine propulsion engines can be installed at angles up to a maximum of 15° flywheel up or flywheel down when static, or can be run at up to 25° when heeling. When our engines are installed at varying angles of inclination the normal markings on the dipstick should be disregarded.

It is probably better to totally drain the lubricating oil from the sump, replacing the oil filter with a new one; then add the recommended amount of lubricating oil – noting its position on the dipstick – and then marking the dipstick. If in doubt ask Beta Marine.

## Alignment

To obtain accurate alignment the flexible mountings must be adjusted until alignment is attained, and the mountings must then be locked in position.

The engine/gearbox unit has to be aligned with the propeller shaft in two ways. The traditional engine alignment method involves measuring with either feeler gauges or a DTI (Dial Test Indicator) mounted on a magnetic foot so that they are aligned within 0.125mm (0.005").

## Angular Alignment

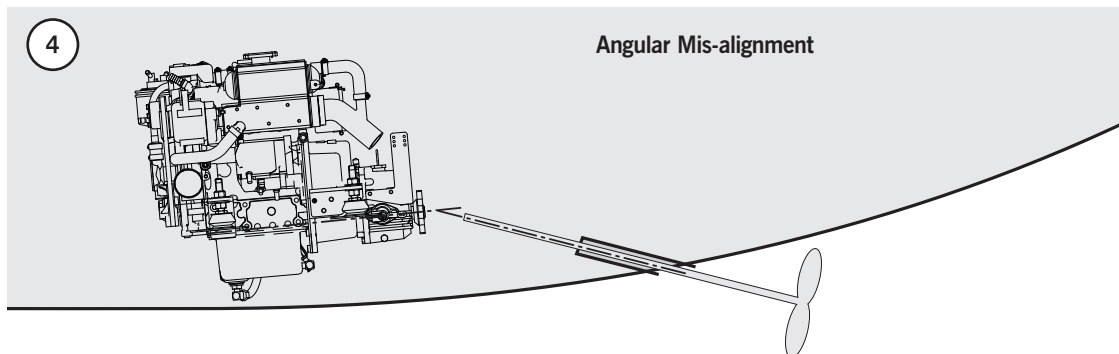
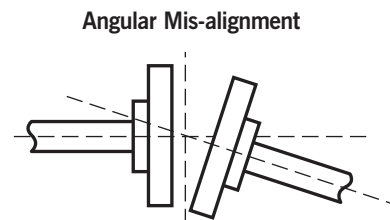
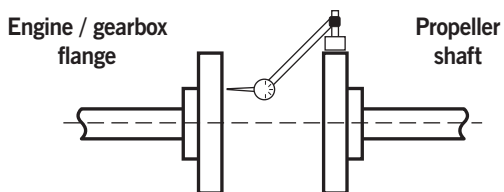

## Parallel Alignment

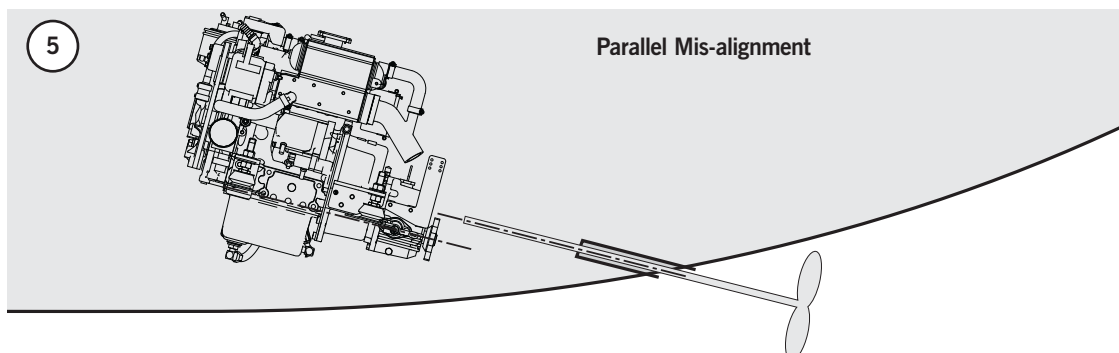
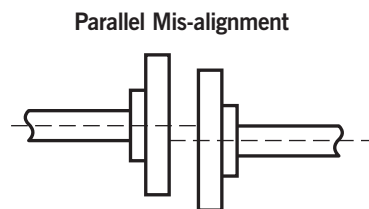
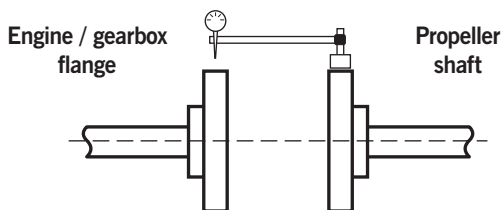

The engine mountings and the couplings must now be tightened in position and the alignment re-checked.



## Flexible Output Couplings

A flexible coupling should be mounted on the gearbox output flange and is strongly recommended in almost every case. Flexible couplings do not accommodate bad alignment, they are designed to absorb torsional vibrations from the propeller (transmitted along the propeller shaft).

---

## Exhausts

We recommend care when designing your exhaust system. The most important aspect is to ensure that the engine will not 'hydraulic lock' - by allowing cooling water into the combustion chamber through the exhaust system.

The basic criteria is when your engine is installed below the water line, the potential for water entering the engine is considerably increased. The important position that must be measured is from the water line to the point at where the cooling water is injected into the exhaust - this should measure 30 cms above the water line.

In yachts, engines are mostly installed low down and often below the water line. There are several ways to avoid cooling water entering the engine:

- (a) Syphoning of cooling water can occur when the rubber impellor of the sea water pump becomes worn. If our standard injection bend is too low then we can offer a high-rise injection bend that adds 15 cms to the height. If this is still not enough then you have to fit an 'antisiphon' valve at least 30 cms above the water line. These valves need to be checked regularly as they have been known to block up with time.
  - (b) We recommend that you always fit a waterlock / silencer to stop any water in the exhaust system back filling the engine. The water lock should always be fitted at least 30 cms from the injection bend and about 15 cms below the injection bend. The waterlock should have sufficient capacity to hold an exhaust system full of water - draining into it.
  - (c) We recommend that you always create a 'gooseneck' with the exhaust hose (or purchase a propriety one) by raising the exhaust hose 40 cms above the waterline before exiting the transom at least 5 cms above the waterline. This will stop any waves pushing seawater down the exhaust.
  - (d) Keep exhaust systems to a minimum length and have gradual bends (NOT right angle elbows). Exhaust back pressure should be as low as possible; it is increased by long exhaust length and sharp bends. Back pressure should be measured; with the complete exhaust system connected and the engine running at full speed. The correct measuring point is before the injection bend (at the manifold flange).
- Beta 10 to Beta 25 maximum 70 mmHg;  
Beta 30 to Beta 60 maximum 80 mmHg,  
and Beta 75 to Beta 105 maximum 90 mmHg.
- (e) Wet Exhaust hose should be matched to the injection bend diameter.
- Beta 10 to Beta 60 is 50 mm internal diameter;  
and Beta 75 & Beta 90 is 60 mm internal diameter.
- (f) An engine correctly installed in accordance with this handbook will meet the emission requirements of the RCD (Recreational Craft Directive).

---

## Typical Yacht Exhaust Installation

### Warning

- (1) One of the most common problems with engine installations (and often expensive), is 'hydraulic lock' (water entering the engine combustion chamber). Water entering the pistons / combustion chamber can cause bent con rods, emulsified engine oil and a wrecked fuel pump! It's best avoided!
- (2) The diagram shows a typical exhaust installation. The rubber hose connecting the heat exchanger to the injection bend must be replaced by a hose of sufficient length, connecting to a "T" piece or anti-syphon valve that is above the maximum seawater level when heeled (at least 30 cms / 12 inches above the water line) on the centre line of the boat. The pipe then returns to the injection bend and the seawater is pumped down the exhaust pipe.

6

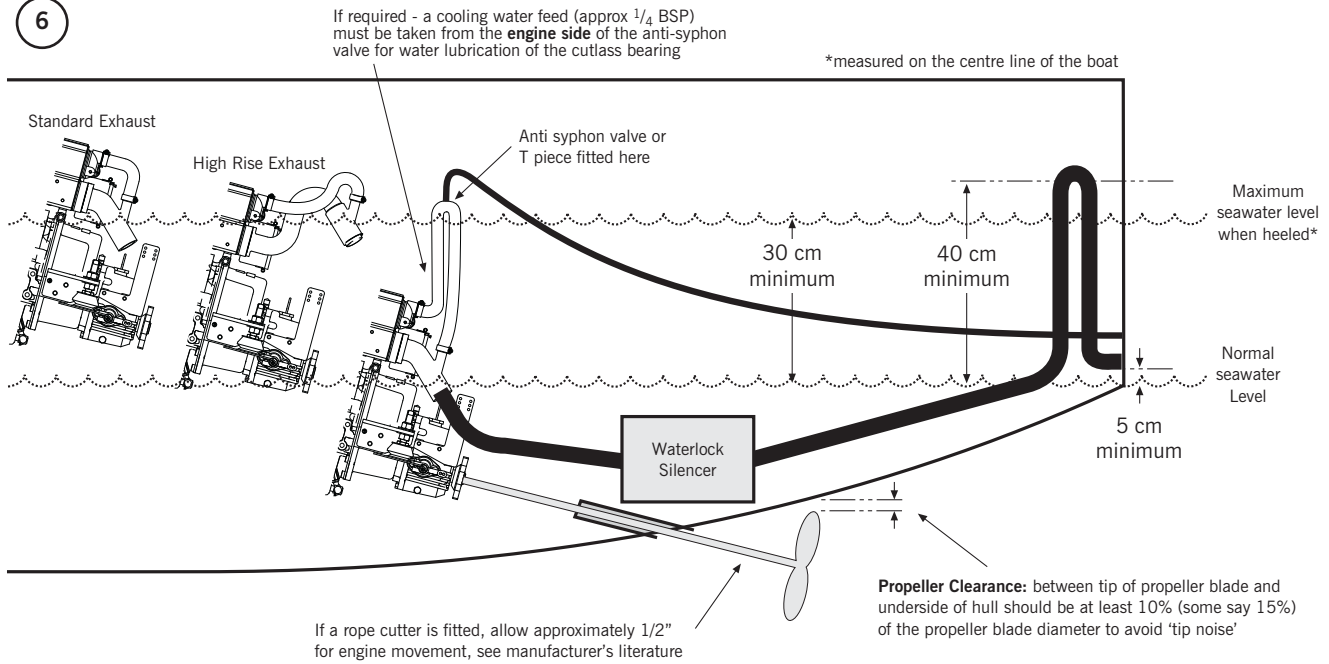

## Dry Exhaust System

- An engine correctly installed in accordance with this handbook will meet the emission requirements of the RCD (see back of manual).
- Keep exhaust systems to a minimum length and have gradual bends (NOT right angle elbows). Exhaust back pressure is increased by longer exhaust length and sharp bends. Back pressure should be measured; with the complete exhaust system connected and the engine running at full speed; and should NOT exceed 70 mm Hg (3.1 inches Hg). The correct measuring point is before the dry exhaust bellows (at the manifold flange). We can supply a Manometer kit for testing 'Back Pressure'.
- The dry exhaust system installed in a canal boat or work boat should be 1 1/2" minimum internal diameter.

The engine is fitted with a 1 1/2" BSP male connector stub as standard - Valid for exhaust systems up to 3 metres in length. A flexible exhaust bellows and dry exhaust silencer should be used. It is up to the installer to work out his own pipe run but care should be taken as follows:

- Never use a flexible exhaust bellow as a bend, it will crack, always keep them straight.
- Ensure that rain water cannot enter the exhaust port and run back down the system, flooding the silencer and eventually the engine. (See drawings below).
- The system should be lagged if there is any danger of the crew getting near it.
- A dry exhaust system will give off considerable heat and suitable ventilation must be provided.

7

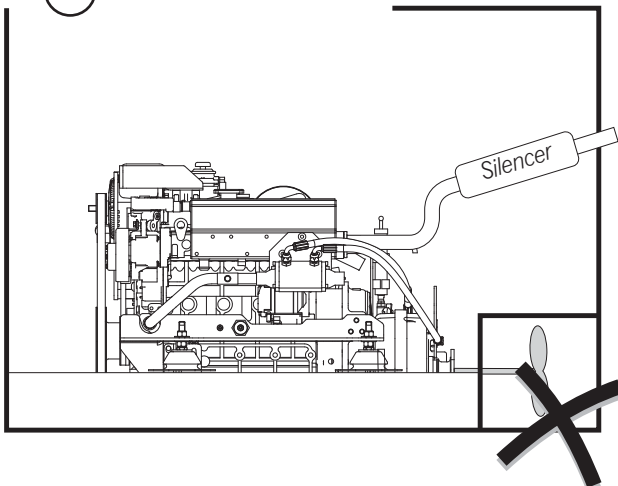

8

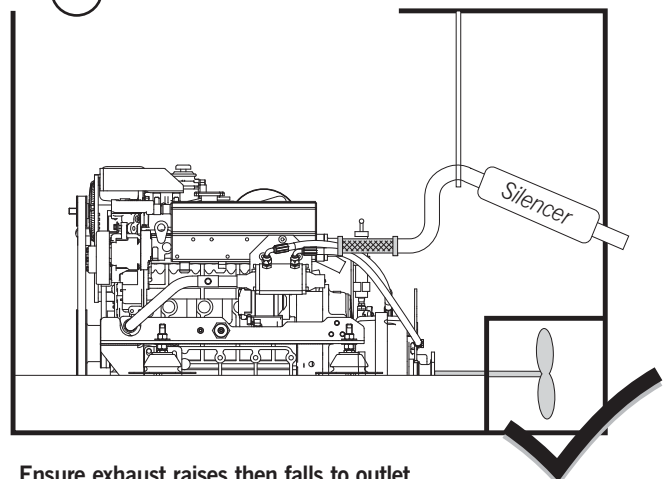

Ensure exhaust raises then falls to outlet

## Engine Connections

Actual Connector:	Required Pipe Size:
Fuel supply and fuel leak-off connections are 8 mm conex with olives	8 mm OD piping for both, a flexible section is required
Heat Exchanger - Yachts	
Seawater cooling pump connections are 22 mm OD Exhaust water injection bend is 50 mm OD	Sea water pump inlet = 22 mm ID hose Flexible rubber exhaust pipe of correct quality = 50 mm ID hose
Keel Cooling - Narrowboats	
Keel cooling connections are 22 mm OD copper pipe Keel cooled exhaust stub is 1½" BSP male thread	Engine inlet and outlet = 22 mm ID hose 1½" BSP female thread flexible exhaust pipe

## Fuel Supply & Leak Off

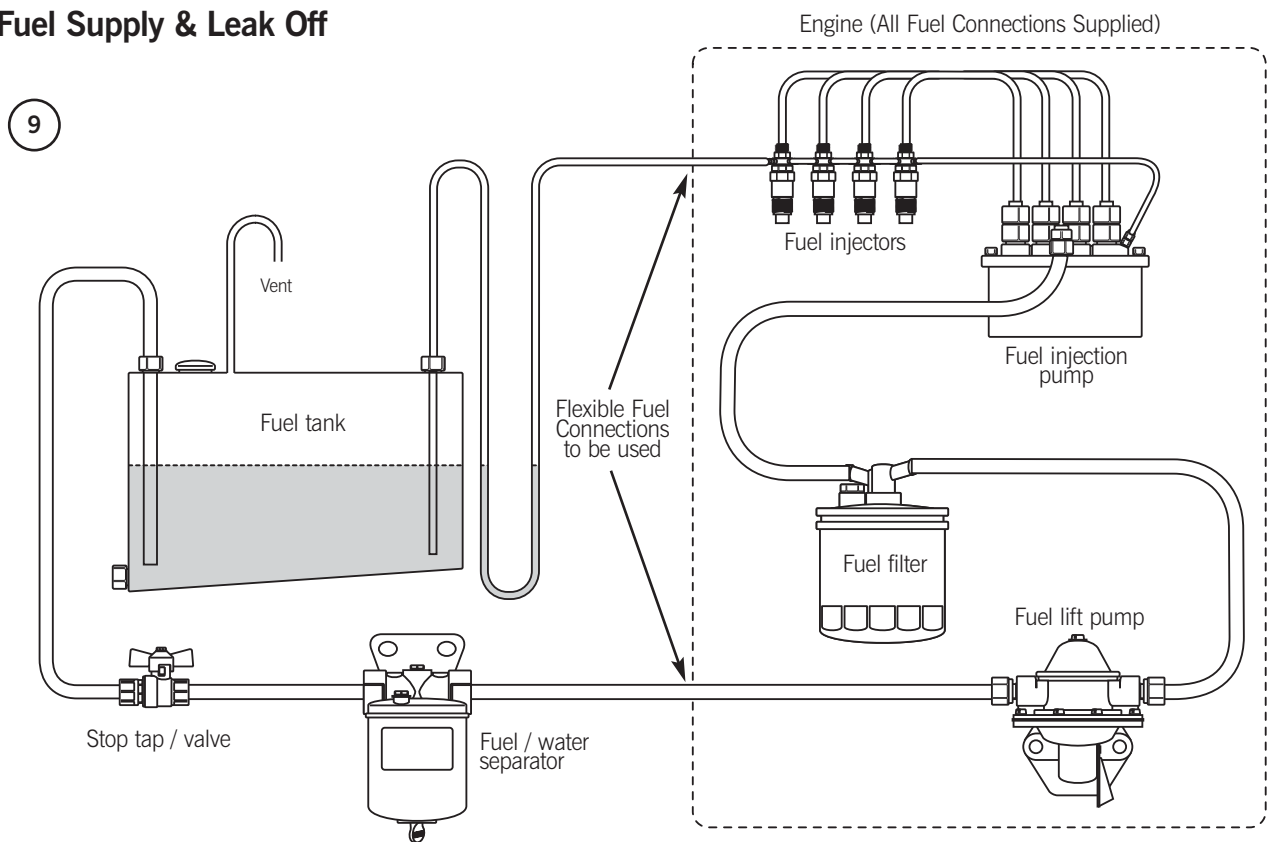

### Notes:

- 1) A fuel/water separator must be installed.
- 2) The mechanical fuel lift pump is fitted to all engines as standard, but if a suction head of 0.25m or more is required, then an electric fuel lift pump must be fitted (ask your dealer or Beta Marine).
- 3) It is very important that the excess fuel from the injectors is fed back to the fuel tank and not back to any point in the supply line. This will help prevent air getting into the system.
- 4) The fuel return (leak off) pipe must loop down to be level with the bottom of the tank before it enters the top of the tank - see drawing. This prevents fuel 'drain down'.
- 5) Fuel lines and hoses connecting the fuel tank to the engine, must be secured, separated and protected from any source of significant heat. The filling, storage, venting, fuel supply arrangements and installation must be designed and installed so as to minimise the risk of fire. When connecting the engine to the fuel supply and return lines, flexible fuel hoses must be used (next to the engine) and must meet the requirements set in standard ISO7840:1995/A1:2000 and/or as required by your surveyor / authority.
- 6) Any fuel leaks in the system when static are likely to cause poor starting and erratic running and must be corrected immediately. These leaks will allow air to be sucked in when the engine is running.

## Seawater Inlet System (Heat exchanger Cooled Engines)

Your engine is fitted with a gear driven sea water pump which sucks in seawater (raw water) to cool the closed circuit system via the heat exchanger.

1. It is very important that the seawater inlet should have a strainer system either built into the sea cock or a high level system with visual inspection glass (as shown) mounted just above the water line.
2. The inlet sea cock should be 1" BSP to which a 7/8" / 22 mm hose connector can be fitted. The sea water pump is 22 mm OD to suit the 22 mm ID hose.
3. Good access to the inlet sea cock is essential so that plastic bags or seaweed trapped in the intake can be poked out.
4. All pipe work should have approved marine grade stainless steel hose clips. Any loose clamps or bad connections can cause flooding and sinking of the vessel
5. If water is required for stern tube lubrication then this should be taken from a 'T' piece in the pipe going from the heat exchanger outlet to the water injection bend.
6. Scoop type water pickups should **never** be used, as water will be forced through the pump and into the exhaust system whilst the vessel is sailing. This is very dangerous as the exhaust will eventually fill and sea/raw water will back up into the engine through the exhaust valve. Catastrophic failure will result as soon as the engine is restarted. **Note:** The maximum lift of the sea water pump is 2m when primed.

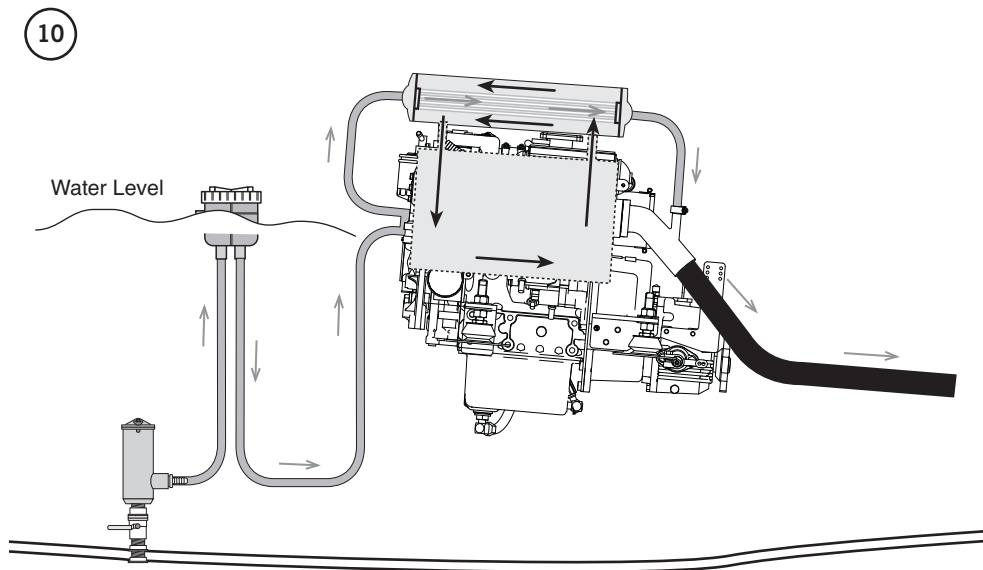

## Canal Boats with Keel Cooling

The Beta 10 to Beta 25 propulsion engines are available with keel cooling if required. The keel cooling supply and return pipes are 22mm diameter; requiring flexible rubber hoses with a 22mm bore. These rubber hoses should be designed and manufactured as hot water heater hoses suitable for operation up to 100 degrees centigrade.

**Narrowboats:** With keel cooling the coolant (same fresh water / antifreeze solution as heat exchanger cooling) flows around the engine and also the keel cooling tanks, before returning to the engine. These keel cooling tanks are normally welded into the 'swim' of the narrowboat, using the 8mm steel plate hull as one side of the tank to transfer the engine heat to the canal water. The required surface area for keel cooling our engines in narrowboats is as detailed.

**A x B = Surface Area**  
(Must Be Below Water Level)

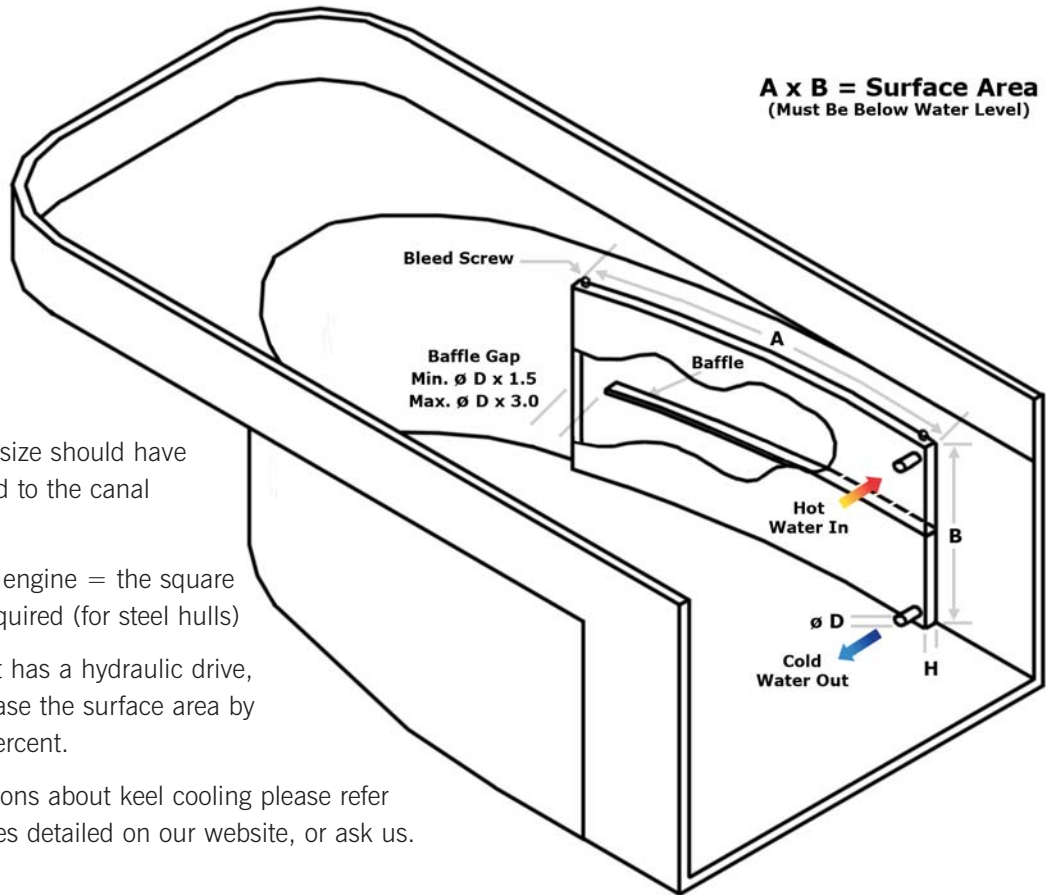

The keel cooling tank size should have a surface area exposed to the canal or sea water of:

0.25 x the bhp of the engine = the square feet of cooling area required (for steel hulls)

**Important:** If you boat has a hydraulic drive, you will need to increase the surface area by approximately 30% percent.

If you have any questions about keel cooling please refer to our design guidelines detailed on our website, or ask us.

Engine Model	Steel Tanks Size (ft)	Steel Tanks Size (m <sup>2</sup> )
Beta 14	3.5	0.33
Beta 16	4.0	0.38
Beta 20	5.0	0.46
Beta 25	6.3	0.59
Beta 30	7.5	0.70
Beta 35	8.8	0.82
Beta 38	9.5	0.88
Beta 43	10.8	1.00
Beta 50	12.5	1.16
Beta 60	15.5	1.43

Efficient keel cooling tanks are side mounted, see illustration. The ideal keel cooling tank should have:

- a) The 'baffle' continuously welded to the outer skin and should be close fitting to the inner skin.
- b) The tank should be thin in section (30mm to 40mm) as it is the heat transfer to the canal or river water that is important.
- c) The tank must have air bleed valves fitted on the top at both ends of the tank.
- d) The hot water feed enters at the top of the tank and the engine return comes out of the bottom.

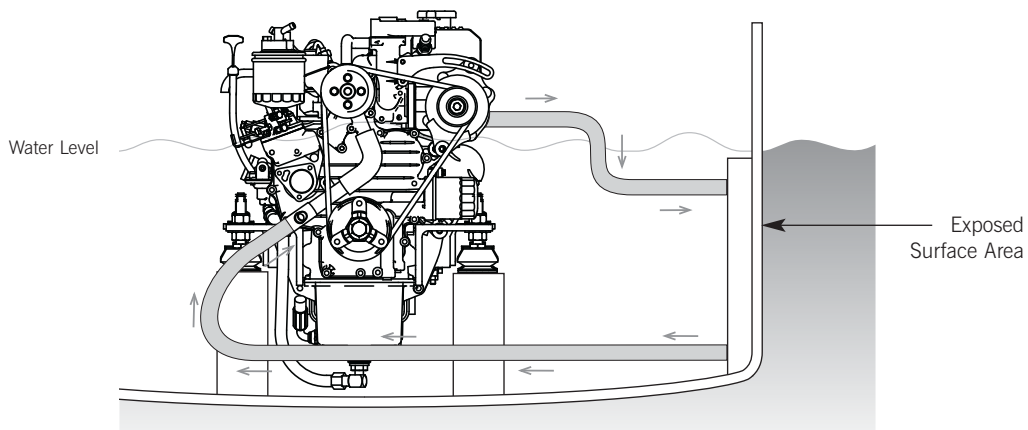

## Calorifier System

All Beta 'Green Line' engines are fitted with 'Calorifier Connections' to allow the hot coolant from the closed cooling system to circulate through a calorifier tank, which in turn heats up domestic water. Photos are shown below.

1. The big problem with a Calorifier is removing all the air from the piping /system. If you cannot get the air out, then the Calorifier will not work!
2. Try and keep the supply and return pipes either horizontal or sloping down in a continuous fall. This avoids air pockets being created.
3. If your calorifier is installed above the engine then a 'Remote Header Tank kit' must be fitted.
4. Extra care must be taken when first filling the calorifier system with coolant (a solution of water plus 30% to 50% antifreeze) as the header tank may appear to be full but it soon disappears into the calorifier pipe work. Run the engine off load for 10 minutes then check the level as described in 'Filling the Fresh Water System'. Also check to see if the pipe going to the calorifier is getting warm after 15 minutes. Top up the water level as required and run for another 10 minutes, then repeat.
5. If the water level is steady but no warm water is getting to the calorifier then very carefully open the calorifier bleed valve (see manufacturers instructions) or if none is provided then very carefully loosen the jubilee clip securing the supply pipe to the calorifier. Air should escape. Refasten securely when no further bubbles are seen.

**Caution:** Do not do this when the engine is hot as scalding hot water may be forced out of the pipe under pressure.

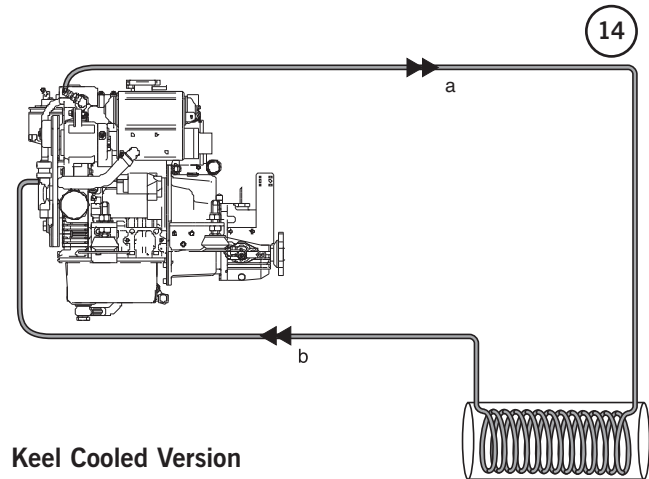
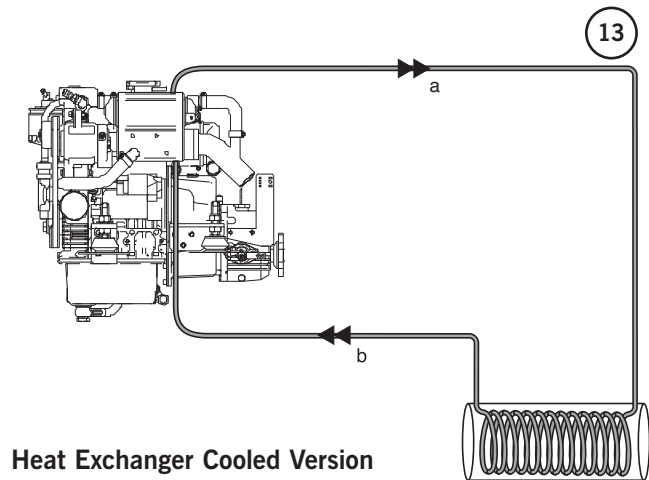

## Heat Exchanger Calorifier System

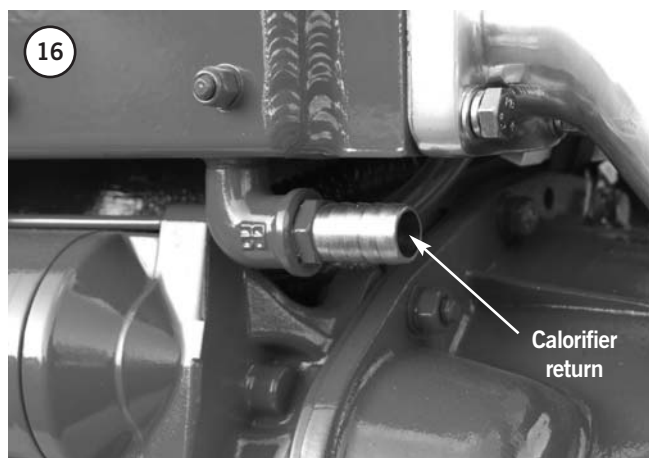
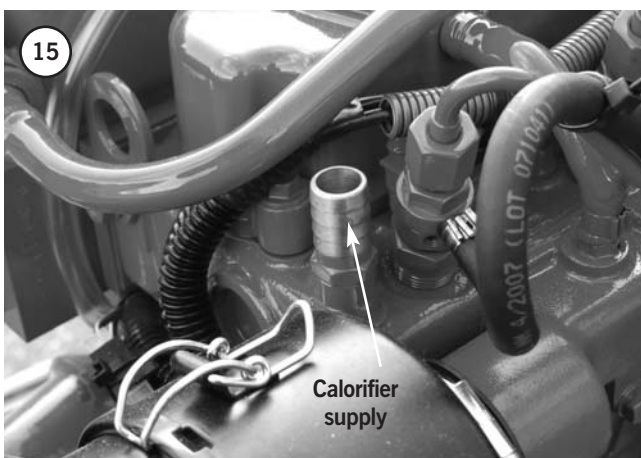

## Electrical Installations

Beta Marine has 6 control panels: A, AB, ABV, ABVW B or C.

The Beta 10 to Beta 25 use the A, ABV, ABVW, B and C control panels.

The engine harness is common to all.

1. These control panels must not be installed where sea water spray can get at them. A suitable flap or cover must be fitted. The ABVW panel is fully waterproof.
2. Control Panels must be fitted in a location where the helmsman can either see or hear the alarm system.
3. For standard wiring diagrams, see back of manual.
4. Our standard wiring harness has a 3 metre loom.  
As an optional extra, Beta can provide various lengths of extension looms for runs of over 3m, but this kit includes a start relay to overcome the voltage drop. (See drawing 300-58520). Care must be taken when pushing the two halves of the plug together to ensure that individual pins do not fall out. To prevent corrosion and assist in assembly we recommend that the plug is packed with petroleum jelly (Vaseline) and then carefully pushed together.

The plastic boots should cover both halves and overlap. A cable tie is then put around to hold the two halves in position and help prevent any ingress of water.

5. All cables must be adequately clipped and protected from abrasion.
6. Electrical systems shall be designed and installed so as to ensure proper operation of the craft under normal conditions of use and shall be such as to minimise risk of fire and electric shock.
7. Attention shall be paid to the provision of overload and short circuit protection of all circuits; except engine starting circuits, supplied from batteries.
8. Ventilation shall be provided to prevent the accumulation of gases, which might be emitted from batteries. Batteries shall be firmly secured and protected from ingress of water.
9. All electrical equipment must be protected from sea water. Sea water or rust in the starter will invalidate the warranty.

## Typical Starter Motor Ratings

Starters used in Kobuta engines have the following standard capacities:

Engine	Starter Capacity (kW)
Less than 700cc	0.8 - 1.0
700 to 1,500cc	1.0 - 1.4
1,500 to 3,000cc	1.4 - 2.0
Over 3,000cc	2.0 - 2.5

## Suggested Minimum Engine Starter Battery Size

Engine	Typical Battery Capacity (AH) at a 20hr Rate	Typical C.C.A Cold Cranking Amperage
Beta 10, Beta 14, Beta 16, Beta 20	35 - 50 AH	350 - 400
Beta 25, Beta 28, Beta 35, Beta 38, Beta 43	65 - 75 AH	450 - 540
Beta 50, Beta 60	100 - 120 AH	580 - 670
Beta 75, Beta 90	150 - 180 AH	1050 - 1200

## Keyswitch Terminations

The standard panel keyswitch can be used to tap off a switched positive ignition feed to power additional gauges. In this way these gauges will only be live whilst the engine is running, the engine is starting or the heaters are being used. For silver keyswitches, the terminal to achieve this ignition switched positive is marked 'AC'. For black keyswitches, the terminal to achieve this ignition switched positive is marked '15/54'. For panels without any keyswitch, gauges can be driven from the 1 mm<sup>2</sup> brown wire which terminates at 11 way connector terminal 4. This is a lower power switched positive, any additional power required from this connection must be feed through a relay, as noted below.

**Note:** these keyswitch terminals are rated at 10 amps maximum, since they are already utilised for panel and alternator feeds Beta Marine recommend any additional requirements from these terminals must be fed through a relay. This relay should then be connected to it's own fused positive supply directly from the engine battery. Beta drawing 202-06421 illustrating the wiring of a typical electric fuel lift pump with ignition switched relay is included in this manual.

# Section 2

## Guidelines for Operation of Engine

### Important Checks Prior to Initial Use

1. Generally, a new engine has the oil and anti-freeze removed after the works test. Fill the engine with the correct oil and antifreeze (see sections on Engine oil and Cooling). **Check gearbox oil level** - see gearbox 'Owners Hand Book'.
2. Ensure the engine is free to turn without obstructions.
3. Ensure battery is fully charged and connected with the battery isolator in the 'ON' position.
4. Ensure "Morse" speed and gearbox cables are fitted correctly and that cable travel lengths are correct. Gear selection lever - all mechanical gearboxes: care must be taken to ensure that the remote control cable is adjusted so that the selector lever on the gearbox moves **full** travel and is brought "hard up" against its end stop in both directions. Failure to achieve the correct adjustment will reduce efficiency of the clutch and may cause slippage at low revs. Warranty will not be accepted on gearboxes returned in the warranty period for failure due to incorrect adjustment.
5. Open the sea water cock - carefully checking there are no water leaks.
6. **Bleeding the fuel system for initial start up.**
  - a) The fuel system must have all the trapped air carefully 'bled' out; starting at the fuel tank and progressively working through to: the fuel/water trap, the fuel filter, to the fuel injection pump.
  - b) Open the fuel tank stop tap/valve and then bleed the fuel/water separator of air as shown in manufacturer's literature.
  - c) Fuel should now arrive at the fuel lift pump.
  - d) Open the fuel bleed screw on top of the fuel filter by 1 to 2 turns, (see photo 18).

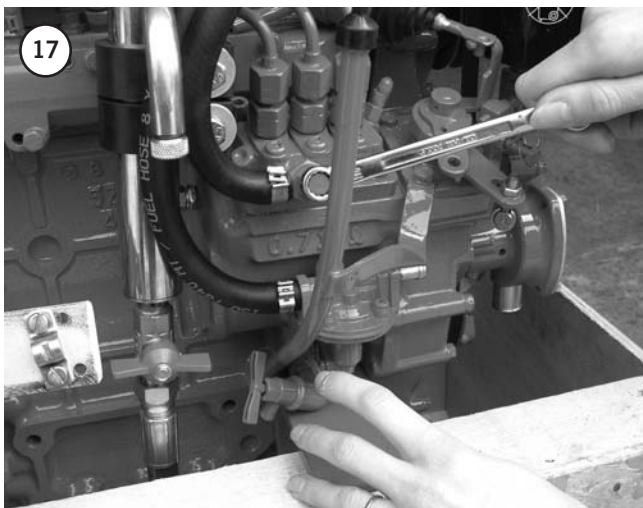

- e) Move the hand priming lever on fuel lift pump up and down (see photo 17) until fuel with "no bubbles" comes out of the fuel filter bleed screw (see photo 18). The hand priming lever normally has about 90° travel; **but the camshaft lobe may block this travel requiring you to rotate the engine to obtain full travel.**
  - f) Shut/tighten the bleed screw.
  - g) Open the bleed screw on the fuel injection pump and again 'bleed' through to the injection pump. Continue to hand prime for 30 seconds to push fuel and any remaining air through the fuel pump. Clean all areas thoroughly of fuel with tissue paper.
7. Ensure engine is **out of gear** and set to  $\frac{1}{3}$  throttle - see "single lever control" instructions/manual.
  8. Start engine (see normal starting). Note the engine may have to be turned over with the starter for a few seconds before it fires. Do not run the starter for more than 20 seconds. If the engine has not started after 20 seconds there is probably still air in the fuel system; disengage the starter and continue to hand prime the engine with the fuel lift pump lever for a further 30 seconds, then repeat. If engine does not start after 3 attempts then allow 5 minutes for the starter to cool down before repeating 6 (c) to 8. **Note: The starter motor windings can be burnt out with continuous cranking.**

### Warning Caution - To avoid personal injury:

- Do not try to start the engine until you know how to stop the engine.
- Do not bleed a hot engine as this could cause fuel to spill onto a hot exhaust manifold creating a danger of fire.
- Do not mix petrol / gasoline or alcohol with diesel fuel. This mixture can cause an explosion.
- Do not get diesel fuel or oil on the flexible mounts - they will deteriorate rapidly if soaked in these.
- All fuel must be removed from skin to prevent infection.



## Normal Starting

### Beta Control Panels - A, AB, ABV, B and C Deluxe - with keyswitch.

**To operate the engine:** with the engine out of gear, set speed control lever to 1/3 throttle.

- 1) Turn key anti-clockwise to 'HEAT' position and hold for ten seconds.
- 2) Turn key clockwise to 'RUN' position. At this stage the instrument panel should illuminate:
  - Green lamp for panel 'power on' should illuminate.
  - Buzzer should sound.
  - Red lamp for 'low oil pressure' should illuminate.
  - Red lamp for 'high engine temperature' should not illuminate (when engine is cold / cool / warm). This lamp will only ever illuminate if the engine is over temperature.
  - Red lamp for 'no starter battery charge' should illuminate.
  - Red lamp for 'no domestic battery charge'. **Only fitted with panels AB and C and will illuminate only if 2nd 'domestic' alternator is fitted.**
- 3) Turn to 'START' position and engine will motor, hold in position until engine fires (see initial start-up section for maximum time starter can be used).



- 4) Release key (when engine has started) to 'RUN' position.
  - All red warning lamps should extinguish and buzzer should stop sounding. The oil pressure lamp may take a few seconds to switch off and the charge fail lamp may remain on until engine rpm is increased to approximately 1,000rpm if the engine was started on tickover.
  - Green lamp for 'panel power on' should still function.
  - If the 'charge fail' lamp remains on then "blip" the engine speed up to 2000 rev/min and it will go out (split charge relay drain).

### Beta Control Panel ABVW - Keyless (without keyswitch)

This panel controls the engine with three water resistant push buttons instead of a keyswitch, and is less prone to damage and corrosion from sea water spray.

**To operate the engine:** with the engine out of gear, set speed control lever to 1/3 throttle.

- 1) Press and hold 'HEAT' button for ten seconds maximum.
  - Green lamp for panel 'power on' should illuminate.
  - Buzzer should sound.
  - Red lamp for 'no starter battery charge' should illuminate.
  - Red lamp for 'high engine temperature' should not illuminate (when engine is cold / cool / warm). This lamp will only ever illuminate if the engine is over temperature.
  - Red lamp for 'low oil pressure' should illuminate.
- 2) Press 'START' button and hold in position until engine fires (see initial start-up section for maximum time starter can be operated). Release button (when engine has started)
  - All red warning lamps should extinguish and buzzer should stop sounding. The oil pressure lamp may take a few seconds to switch off and the charge fail lamp may remain on until engine rpm is increased to approximately 1,000rpm if the engine was started on tickover.
  - Green lamp for 'panel power on' should still function.



- 3) To stop the engine press the 'STOP' push button, hold in until engine stops. This button also switches the power off to the gauges, engine and 'power on' lamp.
- 4) To re-start the engine, simply repeat steps from '1' above, there is no need to switch battery isolators off whilst remaining on board.
- 5) If leaving the boat, isolate start battery from engine and panel, to prevent accidental start up of engine and stop power leakage.

## Stopping

Every propulsion engine is fitted with a stop solenoid. To stop the engine simply press stop push button, hold in until engine stops, then turn key from 'RUN' to 'OFF' position. Do not turn the key to the off position when the engine is running, this will not allow the alternator to charge the battery.

### **Warning!**

**Do not leave the key in 'HEAT' position for more than 15 seconds - this will damage the heater plugs and eventually lead to poor starting.**

### **When leaving the boat for an extended period:**

- Turn off sea-cock (heat exchanger cooled engines).
- Turn off battery isolator.

**Notes for all panel types: Do not depress the stop button for more than ten seconds as this will lead to overheating and failure of the solenoid.** These engines are equipped with a mechanical stop lever in the event of electrical system failure. This lever is located on the starboard side of the engine above the speed control lever. See illustration below. Move the stop lever aft to stop the engine then return it to the run position.

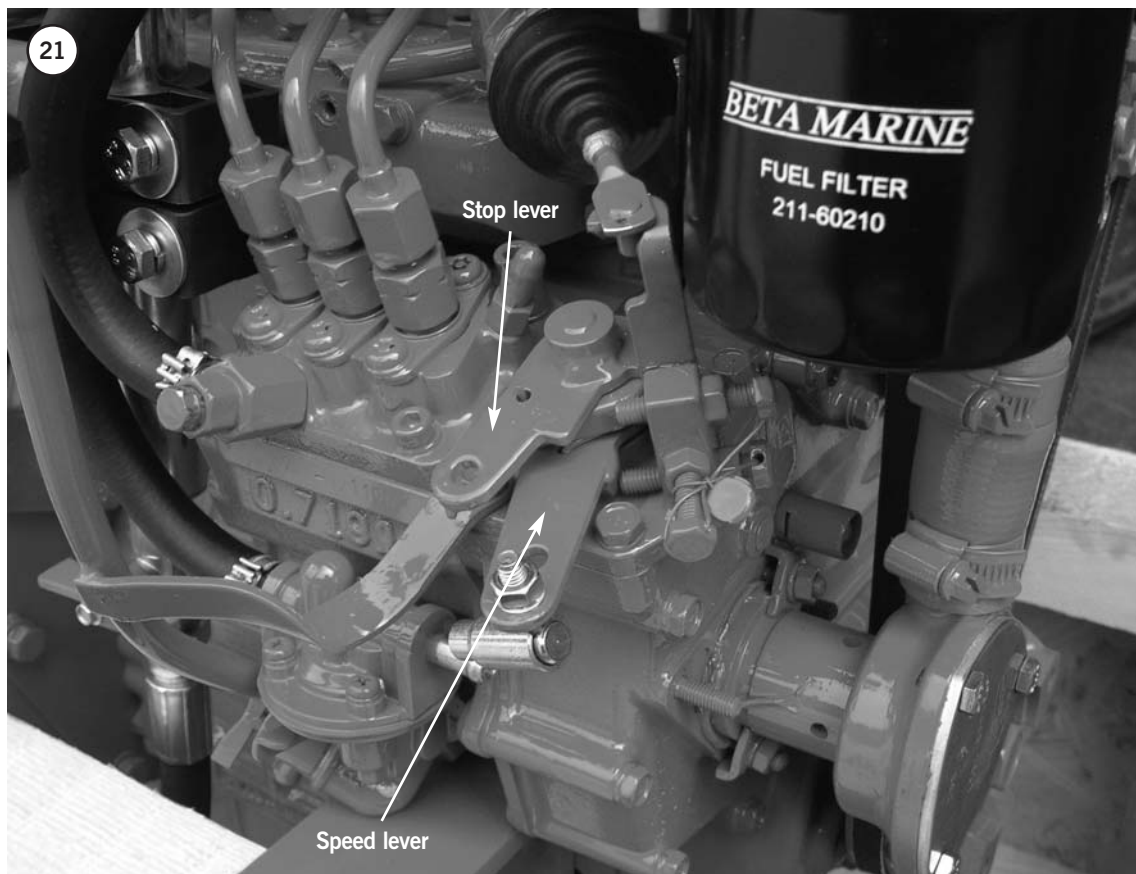

# Section 3

## Maintenance Schedule

### Daily or every 8 hours running

- Check engine oil level.
- Check gearbox oil level.
- Check coolant level.
- Check battery fluid.
- Check drive belt tension
- Ensure raw water inlet strainer is clear.
- Check stern gland lubrication (if used).
- Drain off any water in fuel/water separator.

### After the first 25 hours running

- Change gearbox lubricant (See separate gearbox manual).
- Check that all external nuts, bolts and fastenings are tight. See table for torque values. **Do NOT over tighten.** Special attention should be paid to the flexible mount lock nuts, these should be checked for tightness, starting with lower nut first in each case. If the lower nuts are found to be very loose, then the alignment of the shaft to the gearbox half coupling should be re-checked. Poor alignment due to loose flexible mount nuts will cause excessive vibration and knocking.
- Check the belt tension on any second alternators fitted and adjust, see page 11.
- Check ball joint nyloc nuts for tightness on both gearbox and speed control levers. Grease both fittings all over.

### After first 50 hours

- Change engine lubricating oil.
- Change oil filter.
- Check for leaks on header tank tubestack. Tighten end cap bolt if required.
- Drain off any water in fuel/water separator.

### Every 150 hours

- If shallow sump (option) is fitted, change engine lubricating oil and filter.

### Every year or 250 hours if sooner

- Change engine lubricating oil (standard sump)
- Change lubricating oil filter
- Check air cleaner element
- Check sea water pump impeller and change if worn.
- Check wasting anode condition, replace when necessary. In some environments this may be six monthly or less.
- Remove heat exchanger tube stack, by undoing the bolt each end of the tube stack. Remove end cover, pull out tube stack and clean. Replace rubber 'O' rings and re-assemble. Top up with antifreeze. Immediately engine is started check for leaks.
- Spray the key switch with WD40 or equivalent to lubricate the barrel.
- Check that all external nuts, bolts and fastenings are tight. See table for torque values.
- Check ball joint nyloc nuts for tightness on both gearbox and speed control levers.

### Every 750 hours (In addition to 250 hours maintenance)

- Change air cleaner element.
- Change fuel filter.
- Change antifreeze.
- Change gearbox oil.
- Check electrical equipment, condition of hoses and belts, replace as necessary.

# Maintenance Schedule

	Daily or every 8hrs running	After first 25hrs	After first 50hrs	Every 150hrs with shallow sump	Every Year or 250hrs if sooner	Every 750hrs
Check engine oil level	●					
Check gearbox oil level	●					
Check engine coolant level	●					
Check battery fluid	●					
Check drive belt tension	●					
Ensure raw water inlet strainer is clear	●					
Check stern gland lubrication	●					
Drain off any water in fuel / water separator	●					
<b>Change</b> gearbox oil		●	See separate gearbox manual			
Check all external nuts, bolts and fastenings are tight. Check belt tension. Check for leaks		●	●		●	●
<b>Change</b> engine oil			●	●	●	●
<b>Change</b> oil filter			●	●	●	●
<b>Lubricate</b> keyswitch on control panel with "vaseline" or WD40			●		●	●
Check coolant "sacrificial" zinc anode and replace if necessary - sometimes frequently			●		●	●
Check general condition			●		●	●
Remove heat exchanger tube stack and <b>replace</b> rubber O-rings					●	●
Check sea water pump impeller and <b>change if worn</b>					●	●
Check air cleaner element and <b>change if required</b>					●	●
<b>Change</b> air cleaner element						●
<b>Change</b> diesel fuel filter						●
<b>Change</b> gearbox oil						●
Drain and <b>replace</b> engine coolant / anti-freeze						●

## Lubrication

**Engine oil:** Engine oil quality should have the minimum properties of the American Petroleum Institute "API" classification CF (CD, or CE).

The following table gives grades of oil viscosity required for various ambient temperature ranges.

**Note:** A good quality SAE 15W/40 mineral based multigrade oil as used in most car diesel engines will meet requirements. Do not use lubricant additives, and the use of synthetic oil is not recommended.

Ambient Temp.	Single Grade	Multi-Grade
-30°C to 0°C	SAE 10W	SAE 10W/30
-15°C to +15°C	SAE 20W	SAE 15W/40
0°C to +30°C	SAE 30	SAE 15W/40
25°C and above	SAE 30	SAE 15W/40

## Checking Engine Oil Level

For quantities of oil required see section marked 'Technical Specification', page 4.

When checking the engine oil level, do so before starting, or more than five minutes after stopping.

1. To check the oil level, draw out the dipstick, wipe it clean, re-insert it, and draw it out again. Check to see that the oil level lies between the two notches.

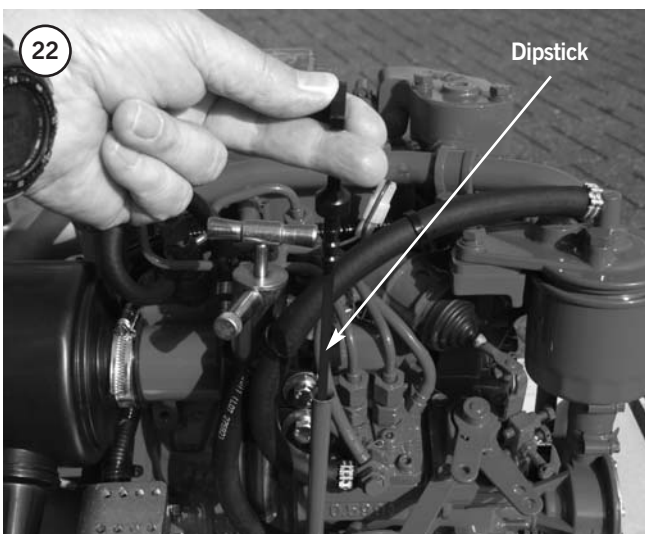

2. If the level is too low, add new oil to the specified level - **Do not over fill.**

**Important:** When using an oil of different make or viscosity from the previous one, drain old oil. Never mix two different types of oil. Engine oil should be changed after first 50 hours running time and then every year or every 250 hours if sooner. Oil filter is a cartridge type mounted on the port side of the engine.



## Changing Engine Oil

- (1) Run the engine for 10 minutes to warm up the oil.
- (2) Drain the engine sump of the used engine oil. Your engine is provided with a sump drain pump (except Beta 10 - an option). Unscrew the end cap on the end of the pump spout, turn the tap to 'on'. Use the hand pump as shown, to pump out the oil into a bucket. When empty turn the tap to 'off' position and replace end cap. See photo 24.

**Note:** On Beta 10 / engines not fitted with sump drain pump, the engine oil must be drained off by unscrewing the sump drain plug (see drawing 100-00030 at back of manual). This is best done with the oil filler cap removed. Replace the plug and tighten firmly.

- (3) Unscrew the oil filter and replace with a new one. See photo 25.

**Note:** It is best to have a plastic bag wrapped round the filter to catch any oil left in the system (Always keep your bilges clean!) Before screwing in the new filter spread a thin film of oil round the rubber gasket to ensure a good seal and screw in - hand tight.

- (4) Fill the engine with new oil as described in the previous paragraph.
- (5) Run the engine and check for oil leaks.

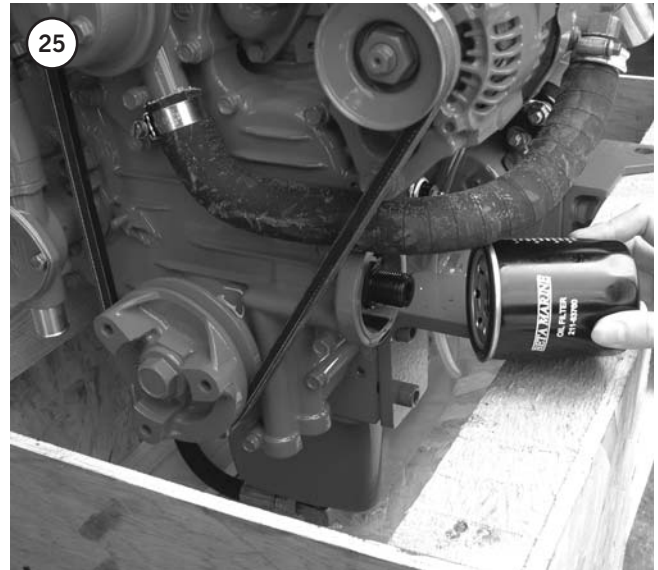
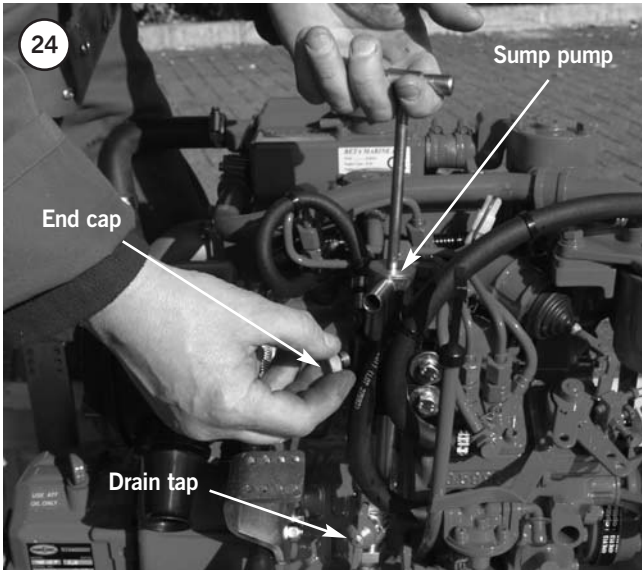

## Checking Gearbox Oil Level

- 1) The gearbox is fitted with a dipstick and oil filler plug, see photo 26.
- 2) Each engine is supplied with a gearbox 'operators manual' which specifies the type of lubricating oil to be used, the capacity and frequency of changing of the oil.
- 3) New engines are often supplied with the gearbox topped up with lubricant but **check the level before starting the engine for the first time.**
- 4) The oil can be changed via the drain plug at the bottom of the box or sucked out with a hand pump via the filler plug.
- 5) A guide to the type of oil to be used is as follows:



Gearbox	Lubricant	Capacity (approx.)
TMC40	Use ATF Oil	0.20 litres
TMC60	Use ATF Oil	0.65 litres
TMC60A	Use ATF Oil	0.65 litres
PRM80	Use Engine Oil 15W40	0.60 litres
PRM120	Use Engine Oil 15W40	0.80 litres
ZF15MIV	Use ATF Oil	1.00 litres

**Note:** ATF is Automatic Transmission Fluid. For additional information see: [www.prm-marine.com](http://www.prm-marine.com)

## Fuel System

### Important

- **Always fit a fuel / water separator in the fuel supply system.** Water in the fuel can seriously damage the injection system and a replacement fuel injection pump is expensive.
  - If a fuel supply shutoff valve is fitted do not use a taper tap, only use a ball valve tap. The ball valve type are more reliable and less likely to let air into the fuel system.
  - Be sure to use a strainer when filling the fuel tank. Dirt or sand in the fuel may cause trouble in the fuel injection pump.
  - Always use diesel fuel. Do not use paraffin / kerosene, which is very low in cetane rating, and adversely affects the engine.
  - Low sulphur diesel fuel - regulations changed recently reducing the sulphur content by 99%, in many countries. The European standard is EN590:2009, and in the USA ASTM D975-09. The engine is designed to run on low sulphur fuel, and this is now preferred.
  - Most diesel fuels now contain up to a maximum limit of 7% Biodiesel and this does not affect the engine warranty.
- The recent changes to fuel specifications allow the addition of FAME (fatty acid methyl ester) biodiesel EN14214:2009, to diesel fuel, but please be aware that biodiesel does allow bacteria to grow more easily in the fuel and this can clog your fuel tank, pipes and filters. If you experience an outbreak of bacterial growth you can either empty and clean out your fuel pipes and tank, or use biocide additives and filtering.
- We know that some customers are using 100% Biodiesel fuel, if you use a higher percentage of Bio-diesel fuel you must fit an electric lift pump into the fuel supply line, and the fuel filter and oil filter must both be changed together when the oil filter is normally replaced. **Important: Beta Marine warranty will not cover fuel equipment when more than 7% Biodiesel is used.**
  - Be careful not to let the fuel tank become empty, or air can enter the fuel system, necessitating bleeding before next engine start.
  - The fuel lift pump will only lift fuel through 0.25m. If this is insufficient then an electric fuel lift pump must be fitted. Drawing 202-06421, illustrating recommended wiring for this pump is included in the back of the manual.

## Fuel Filter Replacement

1. The fuel filter is a spin on type. Remove by turning anti-clockwise when viewed from below.
2. Replace the fuel filter cartridge every 750 hours or every 2 years. See photo 27.
3. Apply fuel oil thinly over the gasket and tighten into position - hand tight.
4. Bleed as detailed - see 'initial start up'.
5. Check for leaks.
6. **Do not get fuel on the flexible mounts**, this will degrade the rubber.



## Filling the Freshwater System

New engines are supplied with the fresh water 'coolant' drained off. The following instructions must be followed to fill the system.

- a) Pour into a clean bucket a mixture of both fresh water and anti-freeze; with an anti-freeze ratio of 33% to 50% (see next page). For the required volume see technical specification page 4.
- b) Check that the coolant drain tap or plug is turned off. See photo 28.

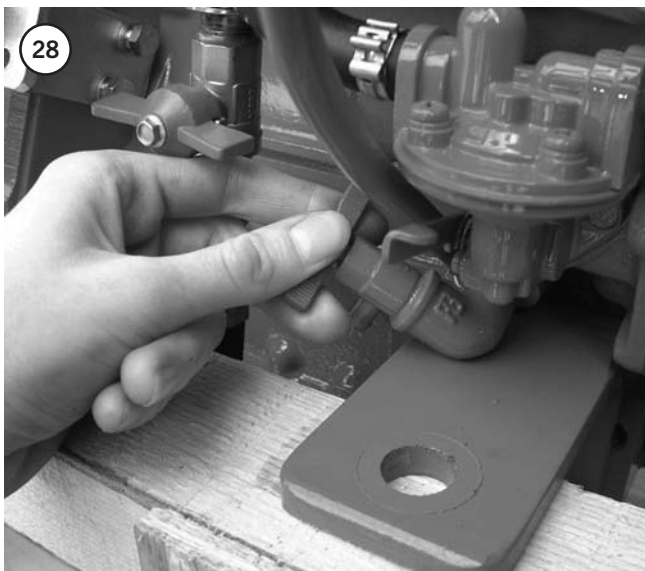

- c) Fill engine with freshwater / anti-freeze solution through the top of the heat exchanger or header tank with the filler cap removed. See photo 29.



- d) Fill header tank to the top of the filler neck and replace cap. Press down firmly on filler cap and hand tighten in a clockwise direction.
- e) Run the engine for 5 minutes on no load (out of gear) and check coolant level, this will help remove air from the system. Top up as necessary.
- f) Check system for leaks.
- g) If a calorifier is fitted care must be taken to see that this is also full of coolant and all the air is removed. (See calorifier fitting notes under Section 1).
- h) Run the engine on one third load for 15 minutes, preferably with the boat tied up. As the system warms up coolant may be expelled from the overflow pipe into the bilge. Stop the engine and allow the engine to cool down before removing the pressure cap and top up the coolant to 25 mm / 1 inch below the filler neck.

**Important:** Removal of the pressure cap when the engine is hot can cause severe injury from scalding hot water under pressure. Always allow the engine to cool and then use a large cloth when turning the cap anti-clockwise to the stop. This allows the pressure to be released. Press firmly down on the cap and continue to turn anticlockwise to release the pressure cap.

- i) Repeat (h) if coolant level is more than 1 inch below the base of the filler neck when the engine has cooled down.
- j) Run engine on  $\frac{2}{3}$  full load for 20 minutes, check for leaks and repeat (i) if necessary.
- k) Anti-freeze solutions should be drained off every 2 years and replaced with a new solution.

**Note:** When draining your fresh water system, ensure the engine has cooled sufficiently to prevent scalding from hot pressurised water. Prior to draining a cold engine, remove the filler cap from the header tank and then open the water drain tap. This allows the water to drain freely from the system.



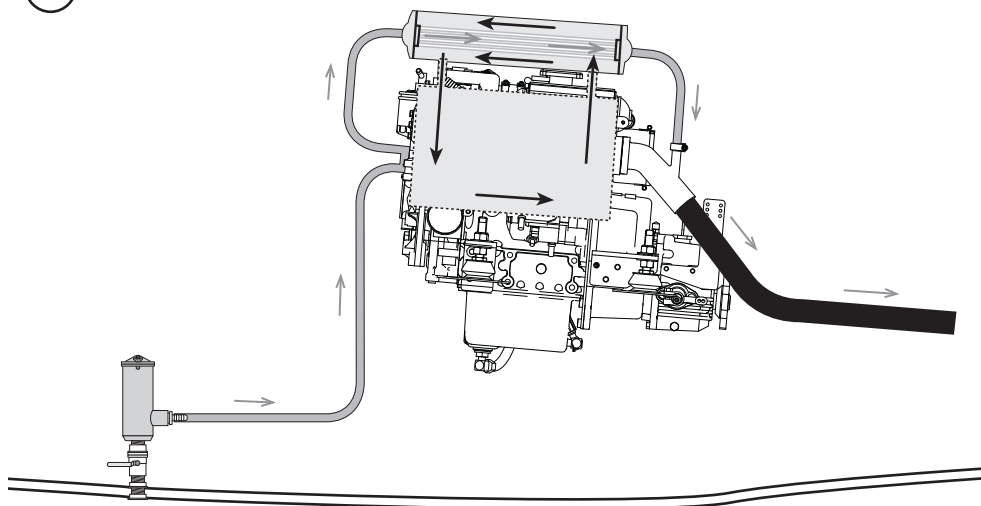

## Heat Exchanger Cooled

Fresh water 'coolant' circulates through the engine and then the heat exchanger body where the engine heat is transferred to the sea water that is pumped through the heat exchanger cooling tubes (tube stack). The heated sea water is then injected into the exhaust system (see diagram).

## Yachts and Launches with Heat Exchanger Cooling

It is essential that a solution of fresh water and anti-freeze is used as engine coolant. The amount of anti-freeze must be between 33% to 50%. This not only stops 'freezing up' in winter, but it prevents overheating and corrosion.

**The warranty is invalid unless the correct ratio is used.  
The concentration of ethylene must NOT exceed 50%.**

The anti-freeze in the fresh water system enables the boiling point of water to rise to 124°C with a 13 psi pressure cap fitted.

The water temperature alarm switch will however be activated at 95°C to 100°C. If no anti-freeze or a very weak solution is used, then the water temperature switch may not be activated before coolant is lost.

## Cleaning the Heat Exchanger Tube Stack and Replacing 'wasting zinc anode'

- (1) The wasting zinc anode should be checked regularly at least every six months and replaced every year or sooner, as necessary. The anode is attached to the bolt inserted in the end cap of the heat exchanger. See photo 31. On most engines this is on the aft end.
- (2) Unscrew the bolt and replace the complete unit with a new one, 209-61840. Check for leaks.
- (3) It is possible for fine sea weed and other debris to get past the inlet filter and into the tube stack. This should be removed and cleaned. See photo 32.

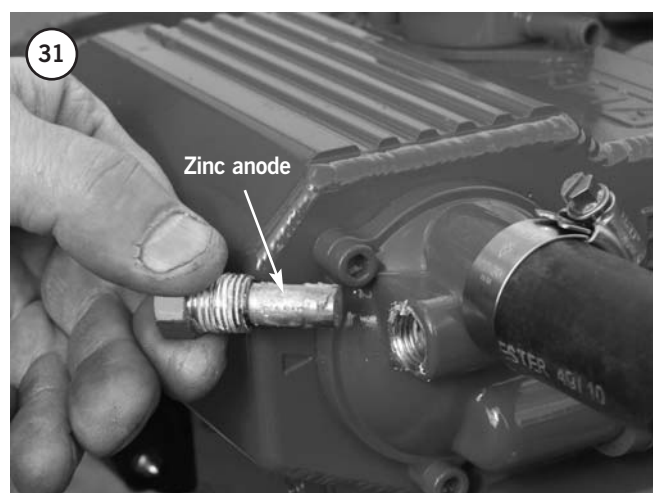

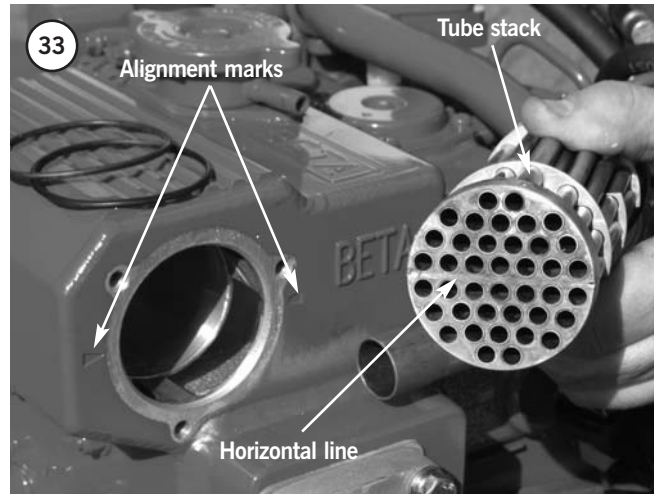
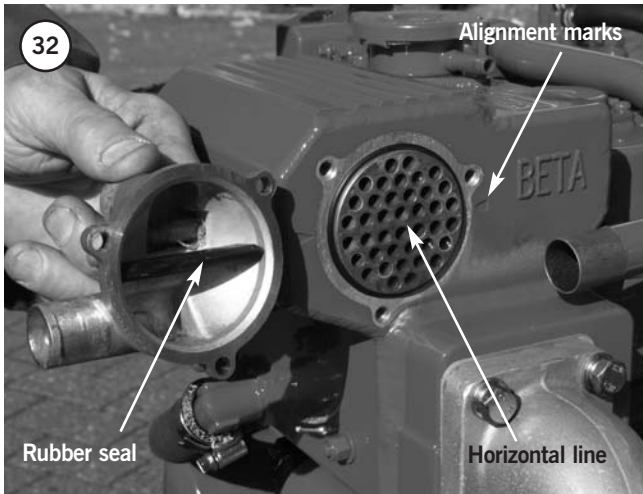

- (4) Drain off coolant into a bucket.
- (5) Unscrew the 6 end cap retaining bolts using a 5 mm Hex key (3 each end of the heat exchanger). Remove the 'O' rings and slide out tube stack. Carefully clean tube stack and end caps.
- (6) Re-assemble using new 'O' rings 212-07273.  
**Important:** The tube stack can be fitted either way

- around but must be aligned correctly with the horizontal line and rubber seal between the alignment marks at the exhaust end of the heat exchanger. (This ensures correct coolant flow in the heat exchanger) Do not over tighten end cap bolts.
- (7) Re-fill engine with coolant (water / anti-freeze solution) and run engine up to temperature to check for leaks.

## Sea Water Pump and Cooling System

(Heat exchanger-cooled engines)

**Caution:** Before working on the sea water system ensure that the **sea cock is in the off position.**

- 1) It is very important that the correct sea water flow is maintained to cool the closed circuit system of the engine. The key component in this system is the sea water pump impeller. This should be checked every year by removing the circular plate. See photo 34.
- 2) Withdraw the rubber impeller from its drive shaft as shown. See photo 35.
- 3) Check impeller for cracks in the rubber, excessive wear or lost vanes. Replace with a new impeller as necessary.

**Note:** If any pieces of rubber impeller are missing then they must be found as they are most likely to be trapped in the entrance to the heat exchanger cooling stack. See 'Cleaning Tube Stack'.

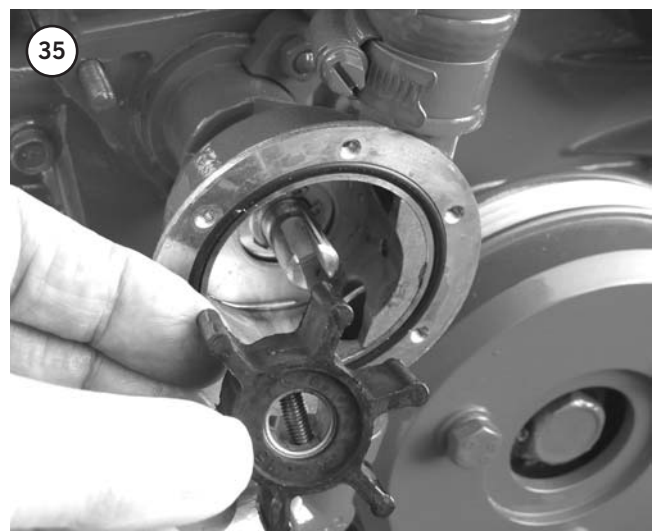

## Belt Tension

**Warning:** Belt tension must only be checked with the engine switched off.

These engines are fitted as standard with a single belt that drives both the 40 Amp battery charging alternator and the fresh water /engine coolant circulating pump.

### 40 Amp alternator (heat exchanger cooled)

- (1) The belt tension is adjusted by swinging the alternator outboard as it pivots on its support bolts. See photo 36.
- (2) With the engine stopped, loosen the support bolts and the link adjusting bolt.

- (3) Push alternator outboard by hand to tension the belt, then tighten link bolt. Check that the depression of the belt (at position shown) is approximately  $\frac{1}{2}$ " or 12 mm when pushed down firmly by thumb. Tighten support bolts. See photo 36.

- (4) Belt tension should be regularly checked especially during the first 20 hours of running in a new belt, as stretching occurs.

### 70 Amp alternator (option)

The same method applies as outlined above with the 'polyvee' flat belt, but final tensioning must be by hand only. Over tensioning will cause premature failure of components.

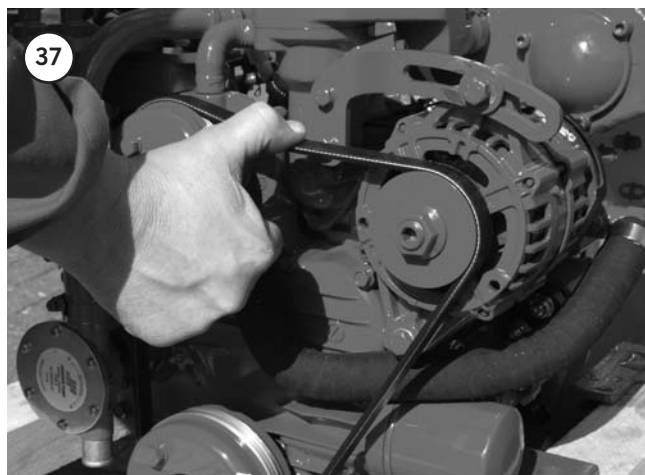
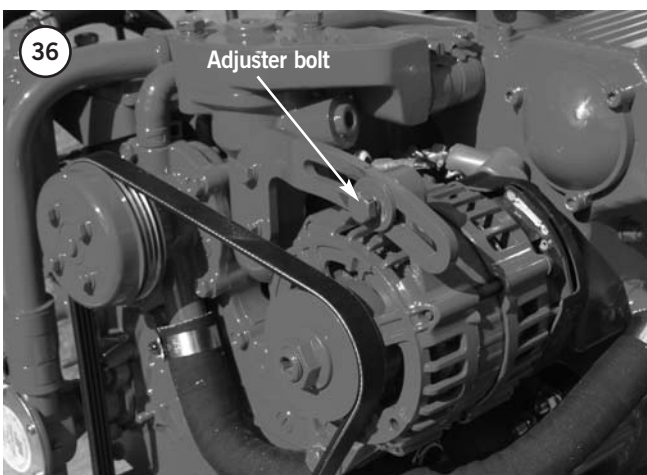

## Air Filter Intake

These engines are fitted with an air intake filter which should be checked every season and changed every 2 years or sooner if badly clogged. If badly clogged check more often.



## Maintenance - Electrical

### **Warning:**

**Under no circumstances should the battery be disconnected or switched off when the engine is running. This will seriously damage the alternator.**

## Panels and Wiring

See installation notes, page 30.

## General Maintenance

- (1) The panel must be protected from rain and sea water, see installation. Sea water entering the key switch will eventually cause corrosion and could result in the starter motor being permanently energised and burning out. Spray key switch every month with WD40 or equivalent; or apply 'vaseline'.
- (2) Check batteries for acid level and top up if required. For low maintenance and 'gel' batteries see manufacturers instructions.
- (3) Loose spade terminal connections are the most common cause for electrical faults - check on a regular bases (see maintenance instructions).

## Winterising and Laying up

### Heat Exchanger Cooled Engines

- a) The engine lubricating oil and lubricating oil filter should be changed at the end of the season rather than in the spring. See section 2.
- b) The closed circuit cooling system must contain an anti-freeze coolant solution. The coolant solution is a mixture of fresh water and anti-freeze (Ethylene Glycol based conforming to BS6580:1992) with the anti-freeze being a minimum of 33% up to a maximum of 50% solution (this also applies to warm and tropical climates). The warranty is invalid if the correct percentage/ratio is not used.
- c) For cold climates where the air or water temperatures can fall below 3°C, the sea water circuit must be protected in addition to the fresh water system. This is best achieved as follows:
  - d) Ensure instrument panel is well protected and give the key switch a spray of WD40 / Petroleum Jelly or equivalent.
  - e) With the engine stopped, disconnect the battery (always disconnect the negative cable first and re-connect the negative cable last) and take it ashore for trickle charging and top up as necessary. If AC power is available then this can be done on the boat.
  - f) Fuel tanks should be kept full during the lay up period to eliminate water condensation in the tank. Water entering the fuel injection system can cause considerable damage.

### Keel Cooled Engines

The requirements for keel cooled engines are basically the same as heat exchanger cooled except:

- a) Special care must be taken to ensure that the whole cooling system is filled with the anti-freeze solution detailed above; this includes the calorifier circuit and the keel cooling tank. If the system has been topped up or refilled then run the engine for 10 to 15 minutes on load (if possible) to get the solution circulated throughout the keel cooling tank and calorifier.

Close the inlet seacock to the engine (engine stopped).

Disconnect the sea water inlet pipe and dip it into a small bucket containing 50/50 anti-freeze solution.

Start the engine (out of gear) and run for 5 to 10 seconds until the anti-freeze is used up and can be seen coming out of the exhaust outlet.

Shut engine off and reconnect the inlet pipe to the seacock. The sea water or raw water circuit is now protected by anti-freeze.

## Laying up Ashore

- a) Change the engine oil before the boat is taken out of the water. Remember that warm engine oil is much easier to pump than cold!
- b) Cooling system - As above in 'Winterising and Laying up' paragraphs (b) to (f) should be followed.
- c) If the engine is to be laid up for more than 6 months then remove the sea water pump impeller.
- d) If the engine will not be used or run for periods longer than 6 months we recommend that the engine is 'inhibited' - this means involves running the engine for about 5 minutes to:

Replace all the diesel fuel in the fuel system and injection pump by running the engine with 'calibration fluid' (fuel pump test oil ISO 4113).

Allow 'Ensis' to circulate around the lubricating oil system by draining out the standard lubricating oil and replacing it with a rust preventative oil such as 'Ensis' or similar.

# Trouble Shooting

Beta diesels are very reliable if installed and serviced correctly, but problems can occur and the following list gives the most common ones and their solution.

<b>Problem: Engine does not start but starter motor turns over OK</b>	
<b>Possible Cause</b>	<b>Solution</b>
No fuel:	Turn fuel cock on and fill tank.
Air in fuel system:	Vent air (see initial start-up)
Water in fuel:	Change fuel filter and bleed system.
Blocked fuel pipe:	Clean out and bleed system.
Fuel filter clogged:	Change filter and bleed system.
Fuel lift pump blocked:	Remove and replace.
Blocked injector:	Remove and clean.
Fuel return not fed back to the tank:	Re-route fuel return pipe.
Heater plugs not working:	Check wiring to the plugs, and replace plugs if they are burnt out.
Stop solenoid stuck in off position:	Check solenoid is free to return to run position.

<b>Problem: Starter motor will not turn or turns over very slowly</b>	
<b>Possible Cause</b>	<b>Solution</b>
Battery discharged:	Charge battery or replace. Check alternator belt tension.
Starter motor flooded with sea water:	Remove and clean or replace.
Wiring disconnected or loose:	Check circuit for loose connections.
Water in cylinders:	Incorrect installation. <b>This is serious</b> - check engine oil for signs of water (creamy-coloured oil). Ring your dealer.
Engine harness fuse blown:	Replace fuse located by starter motor (or above flywheel housing) and check for wiring faults.

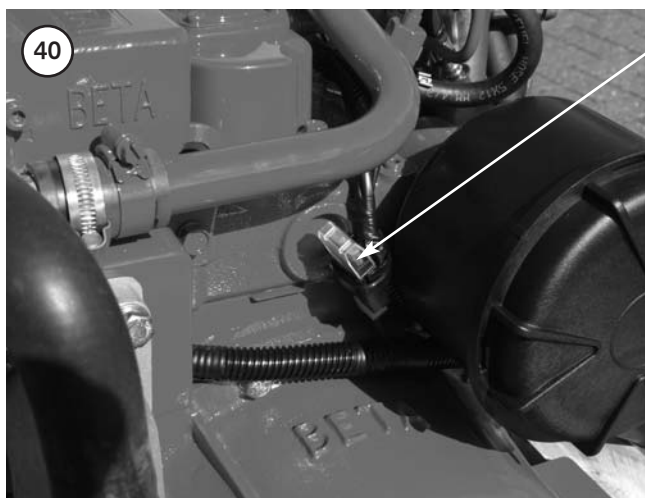

Fuse.

**Note:** For convenience, some engines are supplied with a spare fuse and holder attached to the main engine fuse holder.

## Problem: Low power output

Possible Cause	Solution
Propeller is too big:	Change or depitch.
Check gearbox reduction ratio relative to propeller size:	Change.
Blocked fuel filter:	Replace.
Blocked air filter:	Replace.
Air in fuel system:	Check system and bleed
Governor spring incorrectly mounted:	Dealer to adjust.
Single lever control not operating correctly:	Disconnect speed control cable and move the lever by hand. Adjust cable.
The electrical load is too large on start up:	Disconnect or reduce the load.

## Problem: Erratic running / hunting

Possible Cause	Solution
Air in fuel supply:	Check supply system for leaks and fix.
Fuel lift pump faulty:	Replace.
Clogged fuel filter:	Replace.
Fuel return not fed back to the fuel tank, or blocked pipe:	Re-route pipe or clean.
Air filter blocked:	Replace.
Worn or blocked injector:	Service injectors.
Engine rpm in gear is too low, this must be 850 min:	Increase engine tick over speed.
Faulty stop solenoid:	Disconnect wiring to solenoid. If running improves check for a wiring fault.
Broken fuel injection pump spring:	Replace, this is usually caused by water in the engine oil/fuel
Fuel suction head is too much:	Fit electric fuel lift pump.

## Problem: Hunting at idle

Possible Cause	Solution
Idle adjustment screw may need adjusting:	Speak to Beta Marine for advice with idle adjustment - discuss problem.

## Problem: Hunting at higher speeds

Possible Cause	Solution
Fuel supply problem:	Change fuel filters and check fuel supply.

## Problem: White or blue exhaust gas

Possible Cause	Solution
Engine oil level too high:	Reduce the level.
Blocked injector:	Service injectors.
Piston ring and bore worn or con rod bent due to water ingress, giving a low compression:	Get compression checked by your dealer or Kubota service agent. He will advise action to be taken.
Check that the breather pipe is clear and not obstructed:	Remove and clean out

### **Problem: Black exhaust gas**

<b>Possible Cause</b>	<b>Solution</b>
Blocked air filter element:	Inspect and replace.
Over pitched propeller - engine will not reach its full rpm:	Get the propeller re-pitched if necessary.
Accumulated debris on hull:	Inspect and clean if required.

### **Problem: Low oil pressure warning light on when underway**

<b>Possible Cause</b>	<b>Solution</b>
Oil frothing due to high installation angle or too high oil level:	Refer to Beta Marine for advice

### **Problem: Low oil pressure warning light on when engine speed is reduced to tick over**

<b>Possible Cause</b>	<b>Solution</b>
Faulty switch sender:	Replace.
Engine running too hot:	Check cooling water flow (see section 2 Cooling).
Oil relief valve stuck partially open with dirt:	Remove and clean.
Blocked oil filter:	Change.
Wiring fault:	Check circuit.
Insufficient oil:	Top up and check for leaks.
Problem:	Panel rev counter not working (when fitted).

### **Problem: High oil consumption**

<b>Possible Cause</b>	<b>Solution</b>
Oil leaks:	Check for leaks.
Piston rings worn:	Overhaul required.
Valve stem and guide worn:	Overhaul required.
Piston rings gap facing the same direction:	Shift ring gap position. Service Agent to check.

### **Problem: Water in lubricating oil - general**

<b>Possible Cause</b>	<b>Solution</b>
Core plug pushed out due to frozen block:	Service Agent to check and replace.
Water pump seal damaged:	Service Agent to check and replace.

### **Problem: Water in lubricating oil - heat exchanger cooled**

<b>Possible Cause</b>	<b>Solution</b>
Oil goes "milky" due to seawater entering exhaust manifold:	Check installation - has anti-siphon valve been fitted? Change engine oil and run engine for 10 minutes each time to eliminate any water. Get fuel injection pump and compression checked by Service Agent.



## Problem: Water in lubricating oil - keel cooled

Possible Cause	Solution
Oil goes "milky" due to water entering exhaust manifold and then into the sump:	Check installation - has dry exhaust system been fitted correctly, and ensuring rain water cannot enter the exhaust port and run back? (See Dry Exhaust System). Change engine oil and run engine for 10 minutes each time to eliminate any water. Get injection pump checked by Service Agent.

## Problem: Engine overheats

Possible Cause	Solution
Check coolant level:	Top up.
Pressure cap loose:	Tighten correctly or replace.
Switch sender faulty:	Replace.
Insufficient restrictions in pipe to calorifier:	Clamp off pipe to confirm.
High exhaust back pressure:	Beta 10 to Beta 25 maximum 70 mmHg; Beta 30 to Beta 60 maximum 80 mmHg, and Beta 75 to Beta 105 maximum 90 mmHg.
Keel cooler insufficient size:	Contact boat builder

## Problem: Engine overheats - Heat exchanger only

The most common cause of overheating is insufficient seawater flow due to a blocked intake (weed or a plastic bag!). If this happens then clear the blockage. If the problem is not cured then check the system for sea water flow which should be 15 litres / minute minimum at 1,500 rpm as follows:

- With the boat tied up and out of gear run the engine up to 1500 rpm. Hold a plastic bucket over the exhaust outlet for 10 seconds and measure the amount of water collected\*. Multiply this value by 6 to give the flow in litres/min. Repeat twice and take an average. If the flow rate is noticeably less than the 15 litre per minute minimum at 1,500 rpm, then:
  - Check impeller in sea water pump - if worn replace.
  - If impeller has a vane missing then this will be lodged either in the pipe to the heat exchanger or in the end of the exchanger. This must be removed.
  - Check flow again as in (a).

**\*Note:** This operation must only be done in safe conditions, in port and with two assistants. Working from a rubber dinghy is best. The person holding the bucket should take precautions against breathing in the exhaust gasses.

## Problem: Engine overheats - Keel cooling only

Sometimes overheating is caused by:

- Not fully venting the engine cooling system of air. It is necessary to remove all air from the cooling system - including the "skin" tanks and (if fitted) the Calorifier and associated piping.
- Incorrectly sized "skin" tanks that have been sized for 'usual' canal use (rather than maximum engine output that can sometimes be required) on fast flowing rivers. An additional "skin" tank may need to be fitted; please refer to our website: Inland waterways - Guidelines: keel cooling tank sizes.

### **Problem: Battery quickly discharges**

<b>Possible Cause</b>	<b>Solution</b>
High load and insufficient running:	Reduce load or increase charging time. Large domestic battery banks subject to high electrical loads will take a considerable time to recharge from a single alternator.
Low electrolyte level:	Top up.
Fan belt slipping - black dust in engine compartment, engine compartment temperature too high:	Adjust tension / replace belt with a high temperature type and / or improve engine compartment ventilation.
Alternator defective:	Check with Agent.
Battery defective:	Replace.
Poor wiring connection:	Check wiring system.

### **Problem: Morse control cable will not fit**

<b>Possible Cause</b>	<b>Solution</b>
Incorrect fitting:	Cables are being fitted the wrong way around, switch over and fit the opposite way.

### **Problem: Panel rev counter not working (when fitted)**

<b>Possible Cause</b>	<b>Solution</b>
No W connection to alternator:	Check output from 'W' connection. Should be about 9V AC
Wiring fault:	Check circuit

### **Problem: Transmission noise**

<b>Possible Cause</b>	<b>Solution</b>
Check gearbox oil level:	Top up.
"Singing" propeller:	Check with propeller supplier about 'harmonics'.
Drive plate rattle at tickover:	Check engine rpm (must be 850rpm min. in gear).
Worn drive plate:	Change.
Propeller shaft hitting the Gearbox half coupling:	Move shaft back to give 5mm - 10mm clearance (Type 12/16 couplings only).
Propeller torsionals causing gears to rattle at low rpm:	Fit a torsional flexible coupling such as Centa type 16 or equivalent.

## Problem: Vibrations

Possible Cause	Solution
Poor alignment to shaft:	The alignment must be accurate even if a flexible coupling is used (see section 1, Alignment).
Flexible mounts not adjusted correctly to take even weight:	Check relative compression of each mount.
Flexible mount rubber perished:	Replace. (Diesel or oil will eventually perish most rubbers.)
Loose securing nut on flexible mount:	Check alignment and then tighten the nuts.
Insufficient clearance between the propeller tip and the bottom of the boat:	There must be at least 10% of the propeller diameter as tip clearance between the propeller and the bottom of the boat. Reduce propeller diameter / increase pitch.
Loose zinc anode on the shaft:	Tighten or replace.
Worn cutless bearing or shaft:	Replace.
Weak engine support/bearers:	Check for cracked or broken feet.

## Problem: Knocking noise

Possible Cause	Solution
Propshaft touching gearbox output coupling through split boss or Type 16 coupling:	Adjust, giving correct clearance give 5mm - 10mm between gearbox and propeller shaft
Flexible mount stud touching engine bed:	Adjust stud to clear
Drive plate broken:	Replace / repair
Engine touching engine bed:	Re-align engine / modify bed
Injectors blocked through excess carbon caused by water in the fuel:	Remove and check injector nozzles, replace if required.

## Electrical Fault Finding & Trouble Shooting - Engines built after July 2005 only

The following chart is compiled to aid diagnosis of electrical faults, based on the Beta 10 - 90hp range of engines. If your engine was built before July 2005, contact Beta Marine for the relevant electrical trouble shooting guide.

**Note:** our standard control panels are for earth return installations only (where battery negative cable is connected directly to engine ground). For insulated earth (where battery negative cable is isolated from engine ground) different harnesses, alternators, switches for oil pressure and engine temperature are fitted.

Standard sea specification engines (heat exchanger cooled) are supplied with a single alternator, mounted port side, supplying power to starter battery and control panel.

Standard canal specification engines (keel cooled) are supplied with twin alternators:

- 1st alternator, mounted port side, supplying power to starter battery and control panel
- 2nd alternator, the standard mounting position for this is above the engine on the starboard side (or below 1st alternator on 75 and 90hp), supplying power to the domestic battery system.

Both of these alternators work independently, if the domestic battery system is disconnected, the engine will still run correctly but:

- Domestic charge warning lamp will not function
- Warning buzzer will remain on at all times

**Note:** The two way plug on panel loom will only have a corresponding socket to connect into from the engine if a 2nd alternator is fitted which requires this connection. Engines with only one alternator do not utilise this connection.

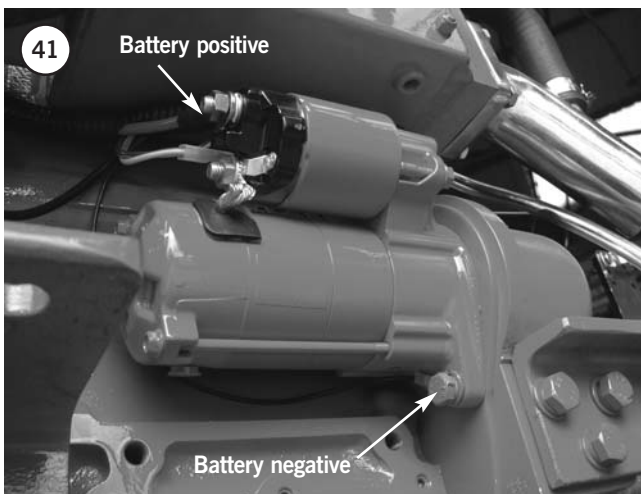



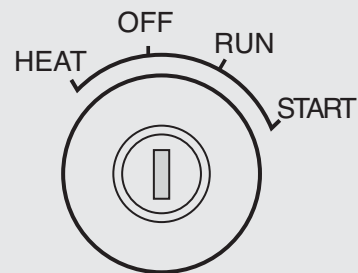

### Standard Keyswitch Control Panels are supplied with four or five lamps.

**Four lamp panels:** A, ABV, B these panels utilise bulbs inside sealed lamp holders.

**Five lamp panels:** AB and C; these panels also utilise bulbs inside sealed lamp holders, having an additional lamp for 'domestic battery charge'.



With keyswitch\* in run position and engine off:

-  Red lamp for 'low oil pressure' should function
  -  Red lamp for 'high engine temperature' should not function (when engine is cold/cool/warm). This lamp will only ever function if the engine is over temperature.
  -  Red lamp for 'no starter battery charge' should function
  -  Red lamp for 'no domestic battery charge' should function (**Note:** this will only function if a second alternator is fitted to the engine and connected to a charged battery)
  -  Green lamp for 'panel power on' should function
- Buzzer should sound



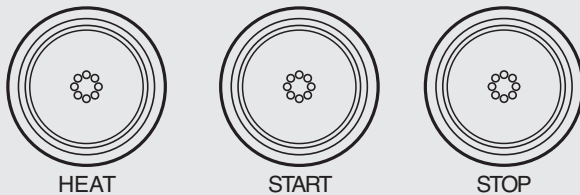

## Electrical Fault Finding & Trouble Shooting - Engines built after July 2005 only

### ABVW - Keyless four lamp panel (without keyswitch)

This panel controls the engine with three water resistant push buttons instead of a keyswitch, and is less prone to damage and corrosion from sea water spray. This panel utilises bulbs inside sealed lamp holders



- 1) Press and hold 'HEAT' button for ten seconds maximum.

-  Red lamp for 'low oil pressure' should function
  -  Red lamp for 'high engine temperature' should not function (when engine is cold/cool/warm). This lamp will only ever function if the engine is over temperature.
  -  Red lamp for 'no starter battery charge' should function
  -  Green lamp for 'panel power on' should function
- Buzzer should sound.

- 2) Press 'START' button and hold in position until engine fires (see initial start-up section for maximum time starter can be operated). Release button (when engine has started).

-  All red warning lamps should extinguish and buzzer should stop sounding. The oil pressure lamp may take a few seconds to switch off and the charge fail lamp may remain on until engine rpm is increased to approximately 1,000rpm if the engine was started at tickover.

-  Green lamp for 'panel power on' should still function.

- 3) To stop the engine press the 'STOP' push button, hold in until engine stops. This button also switches the power off to the gauges, engine and power on lamp. Before investigating any specific electrical problem, always check:

- Connection between panel harness and panel loom. It must be clean, dry and secured with a cable tie.
- Check the start battery is connected to the correct terminal on the starter motor.
- Check the domestic battery is switched on and connected to the correct terminals for the 2nd alternator.
- Battery connections, inspecting condition of cables from battery to engine. If in doubt measure the voltage at the engine.
- If alternator charge problem, measure battery voltage with engine off and again with engine running, if there is an increase alternator is functioning correctly, if not refer to check list.

## Electrical Fault Finding - All Lamp Panels

Problem	Possible Cause and Solution
No warning lamps or buzzer functioning, engine will not start or stop	<ul style="list-style-type: none"> <li>• Battery isolation switch in off position - switch on</li> <li>• Starter battery discharged - charge</li> <li>• Engine fuse blown - check fuse (above starter motor or flywheel housing) and replace if necessary.</li> <li>• Check for wiring faults.</li> </ul>
Non function of warning lamp. <b>The water temperature lamp will not function unless engine is overheating or there is a wiring fault</b>	<ul style="list-style-type: none"> <li>• Disconnect switch wire to non-functioning lamp: green/blue –water temperature, white/brown –oil pressure, brown/yellow –alternator charge. Reconnect wire temporarily to another warning lamp that is functioning; if wire switches lamp on replace faulty lamp.</li> <li>• Disconnect positive feed to non-functioning lamp. Reconnect temporarily with wire from another warning lamp that is functioning, if wire switches lamp on rewire with new connection.</li> <li>• If none of the above, check continuity of connections from panel to engine.</li> </ul>
Water temperature warning lamp on when engine is not over temperature (Not B or C deluxe panel see table on following page)	<p><b>If engine is cold:</b></p> <ul style="list-style-type: none"> <li>• Faulty wiring, check connection and continuity (small green/blue) from switch to panel lamp. Ensure this connection is not shorting to earth (ground).</li> <li>• Faulty temperature switch –if lamp switches off on removal of connection to switch unit, replace.</li> </ul> <p><b>If engine is warm:</b></p> <ul style="list-style-type: none"> <li>• Switch wire connected to large sender terminal of switch/sender unit. Remove and refit to smaller (switch) terminal.</li> </ul>
Buzzer not functioning. <b>The buzzer will not sound for green 'power on' lamp</b>	<ul style="list-style-type: none"> <li>• If lamp is functioning but buzzer not sounding, check connection and continuity from illuminated warning lamp (red not green) to buzzer board.</li> <li>• Faulty warning panel buzzer board - replace.</li> </ul>
Starter battery charge lamp not functioning	<p><b>If tacho not functioning:</b></p> <ul style="list-style-type: none"> <li>• Alternator not connected properly, check continuity of small brown wire from rear of alternator to 'AC' position on keyswitch.</li> <li>• Alternator connected properly, faulty alternator - <b>replace</b></li> </ul> <p><b>If tacho functioning correctly:</b></p> <ul style="list-style-type: none"> <li>• Check continuity of small brown/yellow wire from rear of alternator to no charge warning lamp on rear of panel.</li> <li>• If alternator connected properly, faulty panel warning lamp - replace</li> </ul>
If tacho not functioning	<ul style="list-style-type: none"> <li>• Check connections on rear of tacho, especially black/blue wire, terminal '4'</li> <li>• Check connection of black/blue wire on rear of 1st alternator (W connection, usually a bullet on flying lead, or lowest connection on alternators with 3 pin coupler)</li> <li>• Check continuity of black/blue wire from alternator to tacho</li> <li>• Measure voltage from alternator W connection to earth (ground), should be approx. 7.5 - 9.0 volts AC</li> </ul>
Domestic charge lamp not functioning, buzzer remains on with engine running	<ul style="list-style-type: none"> <li>• Domestic battery not connected</li> <li>• Domestic battery not connected correctly: B+ to domestic isolation block on starboard rail (port on 75 - 95hp) B- to engine earth (ground)</li> <li>• Domestic battery flat</li> <li>• Panel relay faulty / incorrectly wired: Check voltage at relay terminal 86, white wire is positive feed for warning lamp from AC position of keyswitch.</li> </ul>
Domestic charge lamp not functioning, buzzer switching off with engine running. <b>This lamp will only function if a second alternator is fitted to the engine</b>	<ul style="list-style-type: none"> <li>• No second alternator fitted to engine, domestic lamp not used</li> <li>• D+ (charge indication) lamp connection at rear of alternator not connected</li> <li>• Two way plug and socket disconnected between engine harness and panel loom</li> </ul>

## Electrical Fault Finding - C Deluxe and Water Temperature Function on B Panels

In addition to the fault finding detailed on the previous table, the following is specific for the deluxe panel (Also applicable for the B panel with Murphy water temperature gauge)

Problem	Possible Cause and Solution
Oil pressure warning lamp not functioning, oil pressure gauge showing maximum deflection. Engine off and keyswitch in run position	<ul style="list-style-type: none"> <li>Faulty wiring - check wire connection and continuity (small white/brown) from sender to panel lamp. Ensure this connection is not shorting to earth (ground).</li> </ul>
Oil pressure gauge showing no movement - even when engine is started. Warning lamp functioning correctly	<ul style="list-style-type: none"> <li>Faulty wiring - check oil pressure sender wire (small white/brown) is connected.</li> </ul>
Oil pressure showing no movement, Warning lamp not functioning correctly	<ul style="list-style-type: none"> <li>Check connection to oil pressure gauge, if plug is not connected to socket on rear of gauge, reconnect.</li> <li>If all connections are correctly made, possible faulty sender unit - check resistance to earth (ground) approx. 50 <math>\Omega</math> . Replace if no reading or short-circuited.</li> <li>If adjusted correctly &amp; buzzer still sounding, possible faulty switch gauge unit - replace.</li> </ul>
Oil pressure showing normal operating pressure (0.75 - 5 bar). Buzzer sounding and lamp illuminated.	<p><b>Engine warm:</b></p> <ul style="list-style-type: none"> <li>Incorrectly calibrated switching point for warning lamp, adjust on rear of gauge to 0.5 bar (minimum adjustment on gauge).</li> <li>If adjusted correctly &amp; buzzer still sounding, faulty switch gauge unit - replace.</li> </ul>
Water temperature gauge showing 120°C / 250°F. <b>This also applies to the B Panel with Murphy gauge</b>	<p><b>Engine cold / cool:</b></p> <ul style="list-style-type: none"> <li>Faulty wiring, check water temperature sender wire is not shorting to earth (ground).</li> <li>Faulty sender unit, - check resistance to earth (ground), approx. 3.5k <math>\Omega</math> (cold) – 0.5k <math>\Omega</math> (warm). Replace if notably less.</li> </ul>
Water temperature gauge showing normal operating temperature (85°C). Buzzer sounding and lamp illuminated. <b>This also applies to the B Panel with Murphy gauge</b>	<p><b>Engine warm:</b></p> <ul style="list-style-type: none"> <li>Incorrectly calibrated switching point for warning lamp adjust on rear of gauge to 100°C / 210°F.</li> <li>If adjusted correctly &amp; buzzer still sounding, faulty switch gauge unit – replace.</li> </ul>
Water temperature gauge showing no movement, lamp not illuminated, engine warm. <b>This also applies to the B Panel with Murphy gauge</b>	<ul style="list-style-type: none"> <li>Check connection to sender, if disconnected gauge will not function.</li> <li>Check connection to temperature gauge, if plug is not connected to socket on rear of gauge reconnect.</li> </ul>
Water temperature gauge showing no movement, lamp not illuminated, engine warm. <b>This also applies to the B Panel with Murphy gauge</b>	<ul style="list-style-type: none"> <li>Check connection to sender, if disconnected gauge will not function.</li> <li>Check connection to temperature gauge, if plug is not connected to socket on rear of gauge reconnect. If all connections are correctly made, faulty sender unit - check resistance to earth (ground), approx. 3.5k <math>\Omega</math> (cold) – 0.5k <math>\Omega</math> (warm). Replace if no reading.</li> </ul>

## Electrical Fault Finding – Non-Beta Panels

Engines can be supplied wired up to suit VDO switch senders, usually fitted to a non-Beta control panel. If so refer to our wiring diagram 200-60971/01 (also part number for replacement harness)

- Loom is configured differently in the 11-way plug to accommodate the extra wiring.
- Small brown wire (battery sensed alternator feed) fitted with bullet connection beside harness plug.
- Oil pressure and water temperature switch / senders fitted to engine, requiring individual connections for driving gauges and warning lamps.

### Note: Water temperature switch/sender (Part number 200-01133)

Large spade is sender connection	(green/blue)
----------------------------------	--------------

Small spade is switch connection	(blue/yellow)
----------------------------------	---------------

### Oil pressure switch/sender (Part number 200-62680)

G	Gauge wire	(white/brown)
---	------------	---------------

M	Earth (ground)	(black)
---	----------------	---------

WK	Warning lamp	(green/yellow)
----	--------------	----------------

## Electrical Fault Finding – Extension Harnesses

Some installations require one of the panel extensions 11 way connectors to be removed to allow the cable to be passed through bulkheads etc.

If any panel problems are experienced, after this may have been carried out, visually check all 11 way connections on engine harness to panel extension (**and panel extension to panel on C 'Deluxe'**) to ensure wire colours to each terminal match up to the correct colour in its corresponding terminal.

Extra attention must be given to black (ground) and black/blue (tacho), also brown (switched positive to alternator) and brown/yellow (charge fail) as these connections are harder to distinguish between in poorly lit areas. Whilst doing this check integrity of each connection to ensure terminals have not become damaged. Once checked, re-fit cable tie around each connection to keep them secure.

## Electrical Fault Finding – Insulated earth

If your application is wired as insulated earth return and the engine will not operate correctly, always check starter battery negative is connected to the correct terminal on the isolating solenoid.

It should be connected to the terminal which is also used for all the small black wires, **NOT the terminal with the single black wire connected directly to engine ground.**



# Spanner Torque Settings

## Tightening Torques for general use bolts and nuts

ITEM	Size x Pitch	kgf m	lbf ft (ft lbs)	N m
M6 (7T) : 6mm (0.24in)	-	1.0~1.15	7.2~8.3	9.8~11.3
M8 (7T) : 8mm (0.31)	-	2.4~2.8	17.4~20.3	23.5~27.5
M10 (7T) : 10mm (0.39in)	-	5.0~5.7	36.2~41.2	49.0~55.9
M12 (7T) : 12mm (0.47in)	-	7.9~9.2	57.1~66.5	77.5~90.5

## Tightening Torques for special use bolts and nuts

Head Bolts	M8 x 1.25	3.8~4.3	27.5~31.1	37.3~42.2
Bolts, Connecting Bolts	M7 x 0.75	2.7~3.1	19.5~22.4	26.5~30.4
Bolts, Flywheel	M10 x 1.25	5.5~6.0	39.8~43.4	53.9~58.8
Bolts 1, Bearing Case	M6 x 1.0	1.3~1.6	9.4~11.6	12.7~15.7
Bolts 2, Bearing Case	M7 x 1.0	2.7~3.1	19.5~22.4	26.5~30.4
Nozzle Holder Assembly	M20 x 1.5	5.0~7.0	36.2~50.6	49.0~68.6
Caps Nuts, Head Cover	M6 x 1.0	0.4~0.6	2.9~4.3	3.9~5.9
Glow Plugs	M8~1.0	0.8~1.5	5.8~10.8	7.8~14.7
Oil Switch	PT 1/8	1.5~2.0	10.8~14.5	14.7~19.6
Nuts, Rocker Arm Bracket	M6 x 1.0	1.0~1.15	7.2~8.3	9.8~11.3
Bolts, Idle Gear Shaft	M6 x 1.0	1.0~1.15	7.2~8.3	9.8~11.3

## Index - Wiring Diagrams and General Arrangements

1. Typical starter motor ratings		Page 13
2. Suggested engine starter battery size		Page 13
3. Keyswitch terminations		Page 13
4. Standard engine harness (40 Amp)	200-05444	Page 41
5. Standard engine harness (70 Amp)	200-05495	Page 42
6. Diagram of extension harness	200-04588	Page 43
7. Diagram of panel 'A' & cut-out	200-06516 & 200-06305	Page 44 & 45
8. Diagram of panel 'AB' & cut-out	200-06517 & 200-06304	Page 46 & 47
9. Diagram of panel 'ABV' & cut-out	200-06519 & 200-06320	Page 48 & 49
10. Diagram of panel 'ABVV' & cut-out	200-06333 & 200-06331	Page 50 & 51
11. Diagram of panel 'B' & cut-out	200-06520 & 200-06303	Page 52 & 53
12. Diagram of Deluxe panel 'C' & cut-out	200-06518 & 200-06306	Page 54 & 55
13. GA of Beta 10 H/E TMC 40	100-00030	Page 56
14. GA of Beta 14 H/E TMC 40	100-06019	Page 57
15. GA of Beta 14 H/E TMC 40 with Atomic feet	100-01973	Page 58
16. GA of Beta 14 'Bobtail'	100-06357	Page 59
17. GA of Beta 16 H/E TMC 40	100-06496	Page 60
18. GA of Beta 20 H/E TMC 40	100-99610	Page 61
19. GA of Beta 20 H/E 7° Down angle	100-09154	Page 62
20. GA of Beta 20 H/E Saildrive	100-08835	Page 63
21. GA of Beta 20 K/C PRM80	100-05749	Page 64
22. GA of Beta 25 H/E TMC 40	100-06495	Page 65
23. GA of Beta 25 H/E 'V' Drive ZF15 MIV	100-08483	Page 66
24. Split charge relay wiring (65 Amp)	300-62210/05	Page 67
25. Blocking diode split charge installtion	300-62220	Page 68
26. Starter relay wiring - over 4 metres	300-58520/01	Page 69
27. Electric Fuel Lift Pump	202-06421/01	Page 70
28. Declaration of Conformity for Recreational Craft		Page 71 & 72
29. Emission durability		Page 73
30. Quick reference parts list		Page 76, 75 & 74
31. Maintenance record and service items		Inside back cover

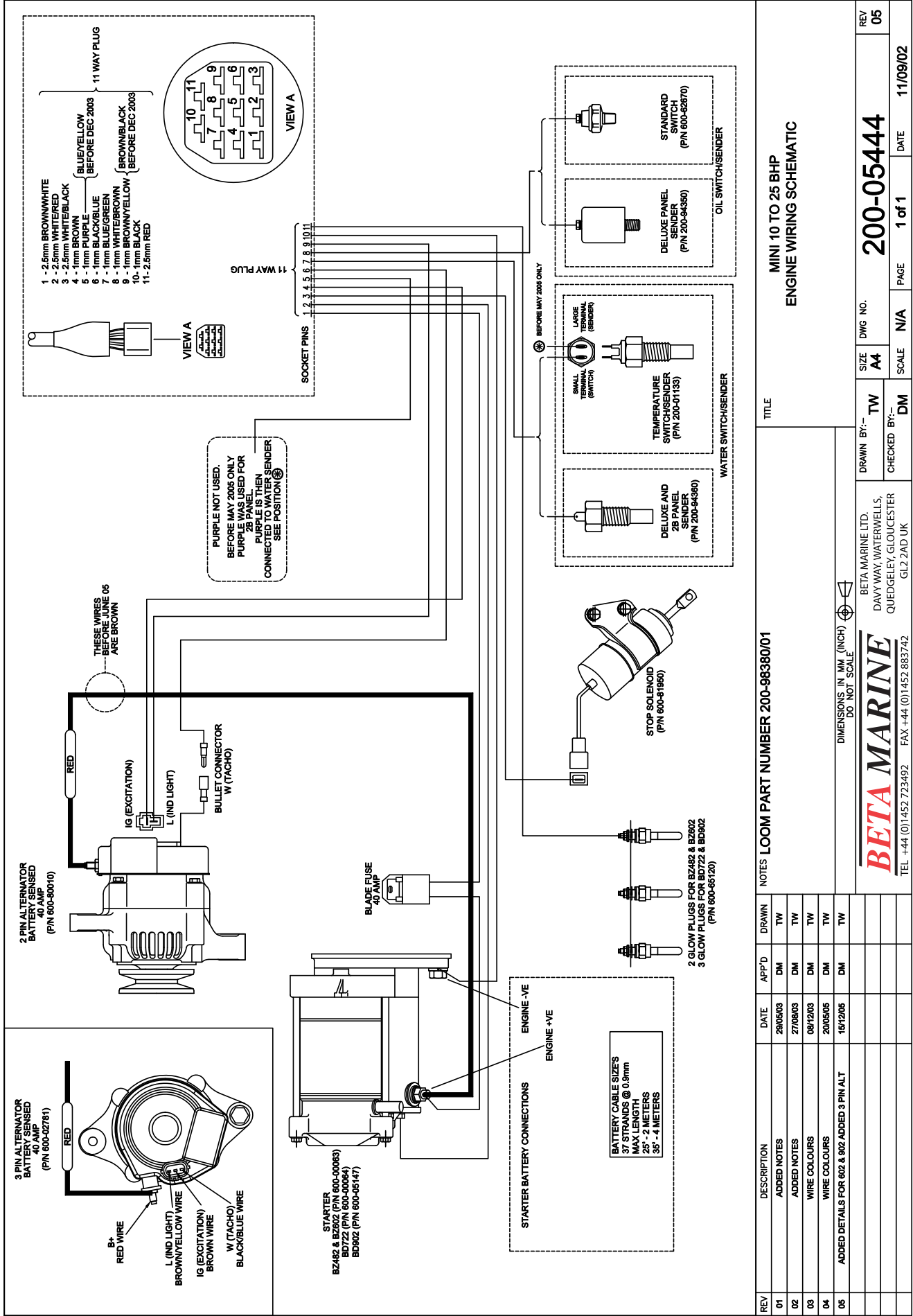

REV	DESCRIPTION	DATE	APP'D	DRAWN	NOTES	TITLE	
01	ADDED NOTES	29/05/03	DM	TW	LOOM PART NUMBER 200-98380/01	MINI 10 TO 25 BHP ENGINE WIRING SCHEMATIC	
02	ADDED NOTES	27/08/03	DM	TW			
03	WIRE COLOURS	06/12/03	DM	TW			
04	WIRE COLOURS	20/05/05	DM	TW			
05	ADDED DETAILS FOR 602 & 902 ADDED 3 PIN ALT	15/12/05	DM	TW			
<p style="text-align: center;">DIMENSIONS IN MM (INCH) DO NOT SCALE</p> <p style="text-align: center;"><b>BETA MARINE</b> BETA MARINE LTD. DAVY WAY, WATERWELLS, QUEDGELEY, GLOUCESTER GL2 2AD UK TEL +44 (0)1452 723492 FAX +44 (0)1452 883742</p>							
REV	05	DWG NO.	200-05444	SCALE	1 of 1	DATE	11/09/02
REV	05	SIZE	A4	SCALE	N/A	PAGE	1 of 1
REV	05	DRAWN BY	TW	CHECKED BY	DM		

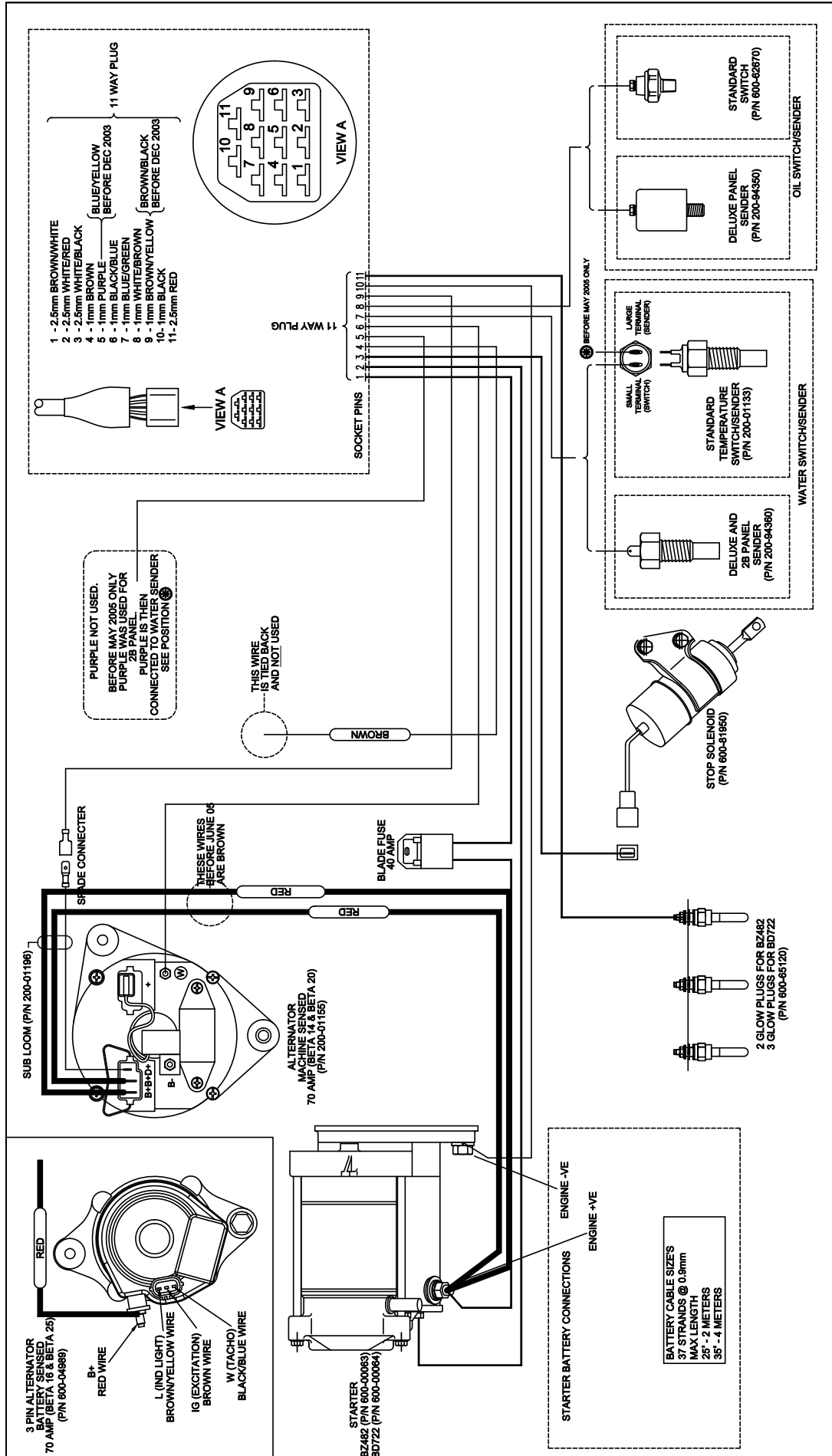

REV	DESCRIPTION	DATE	APP'D	DRAWN	NOTES	TITLE	SCALE	N/A	PAGE	DATE	REV	
01	WIRE COLOURS	08/12/03	DM	TW		<b>LOOM PART NUMBER</b> 200-98380/01 - ENGINE HARNESS 200-01196 - ALTERNATOR SUB LOOM	A4				<b>200-05495</b> MINI BETA10, BZ482 AND BD722 ENGINE WIRING SCHEMATIC WITH ISKRA 70AMP	05
02	WIRE COLOURS AND NOTES	30/03/04	DM	TW			DM		1 of 1	24/10/02		
03	CHANGED NOTES	18/05/05	DM	TW			DM					
04	ADDED SMALL 70 AMP ALT	15/12/05	DM/T	TW			DM					
05		08/01/08	DM/T	TW			DM					
06							DM					

VIEW LOOKING ON CONNECTOR FACE  
FITTED WITH FEMALE SPADE/BULLET

- 1 - 2.5mm BROWN/WHITE TRACER
- 2 - 2.5mm WHITE/RED TRACER
- 3 - 2.5mm WHITE/BLACK TRACER
- 4 - 1mm BROWN
- 5 - 1mm PURPLE
- 6 - 1mm BLACK/BLUE TRACER
- 7 - 1mm BLUE/GREEN TRACER
- 8 - 1mm WHITE/BROWN TRACER
- 9 - 1mm BROWN/YELLOW TRACER
- 10 - 1mm BLACK
- 11 - 2.5mm RED
- 12 - 1mm GREEN/YELLOW TRACER
- 13 - 1mm BLUE/YELLOW TRACER
- 14 - 1mm YELLOW

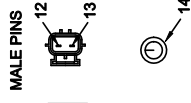
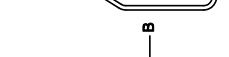
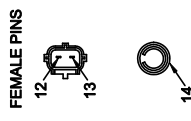
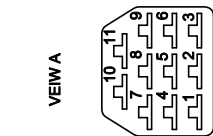

- 1 METER - PIN 200-04588/01
- 2 METER - PIN 200-04588/02
- 3 METER - PIN 200-04588/03
- 4 METER - PIN 200-04588/04
- 5 METER - PIN 200-04588/05

ALL UNUSED WIRES PLEASE LEAVE AT 140mm LONG

VIEW LOOKING ON CONNECTOR FACE  
FITTED WITH MALE SPADE/BULLET

- 1 - 2.5mm BROWN/WHITE TRACER
- 2 - 2.5mm WHITE/RED TRACER
- 3 - 2.5mm WHITE/BLACK TRACER
- 4 - 1mm BROWN
- 5 - 1mm PURPLE
- 6 - 1mm BLACK/BLUE TRACER
- 7 - 1mm BLUE/GREEN TRACER
- 8 - 1mm WHITE/BROWN TRACER
- 9 - 1mm BROWN/YELLOW TRACER
- 10 - 1mm BLACK
- 11 - 2.5mm RED
- 12 - 1mm GREEN/YELLOW TRACER
- 13 - 1mm BLUE/YELLOW TRACER
- 14 - 1mm YELLOW

REV	DESCRIPTION	DATE	APP'D	DRAWN	NOTES
01					

TITLE		EXTENSION HARNESS	
DRAWN BY: TW		CHECKED BY: LT	
BETA MARINE LTD. DAVY WAY, WATERWELLS, QUEDGELEY, GLOUCESTER GL2 2AD UK		SCALE NTS	
DIMENSIONS IN MM (INCH) DO NOT SCALE		SIZE DWG NO. A4	
REV 00		PAGE 1 of 1	
DATE 15/10/04		REV 00	

**BETA MARINE**  
 TEL +44 (0)1452 723492 FAX +44 (0)1452 883742  
 BETA MARINE LTD.  
 DAVY WAY, WATERWELLS,  
 QUEDGELEY, GLOUCESTER  
 GL2 2AD UK

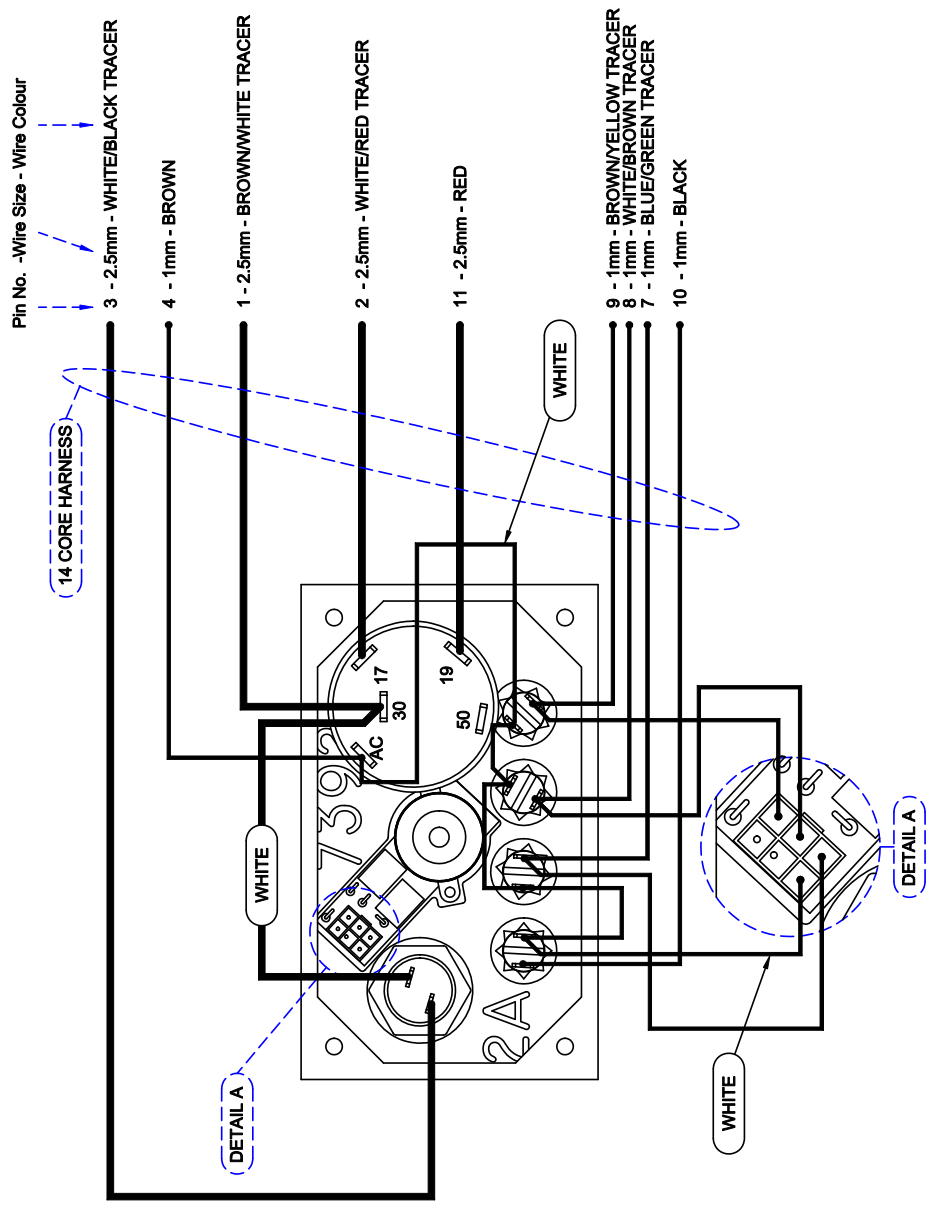

Pin No. - Wire Size - Wire Colour

14 CORE HARNESS

3 - 2.5mm - WHITE/BLACK TRACER

4 - 1mm - BROWN

1 - 2.5mm - BROWN/WHITE TRACER

2 - 2.5mm - WHITE/RED TRACER

11 - 2.5mm - RED

WHITE

9 - 1mm - BROWN/YELLOW TRACER

8 - 1mm - WHITE/BROWN TRACER

7 - 1mm - BLUE/GREEN TRACER

10 - 1mm - BLACK

WHITE

DETAIL A

11 WAY PLUG

VIEW A

PIN NO.

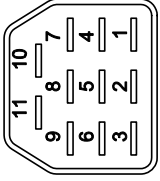

VIEW A

PINS 5 AND 6 ARE NOT USED IN THIS ARRANGEMENT. THERE ARE SOME SPARE CORES UNUSED IN THE HARNESS.

REV	DESCRIPTION	DATE	APP'D	DRAWN	NOTES	TITLE	SCALE	N/A	PAGE	DATE	REV
.						FOR PART LIST AND PANEL SIZE SEE DRAWING 200-06305 PANEL PART NUMBER 200-00852	A4	N/A	1 of 1	15/05/05	
							DIMENSIONS IN MM (INCH) DO NOT SCALE				
							DRAWN BY:- TW				
							CHECKED BY:- DM				
							BETA MARINE LTD. DAVY WAY, WATERWELLS, QUEDGELEY, GLOUCESTER GL2 2AD UK				
							TEL +44 (0)1452 723492 FAX +44 (0)1452 883742				
							<b>BETA MARINE</b>				
							DWG NO. 200-06516				

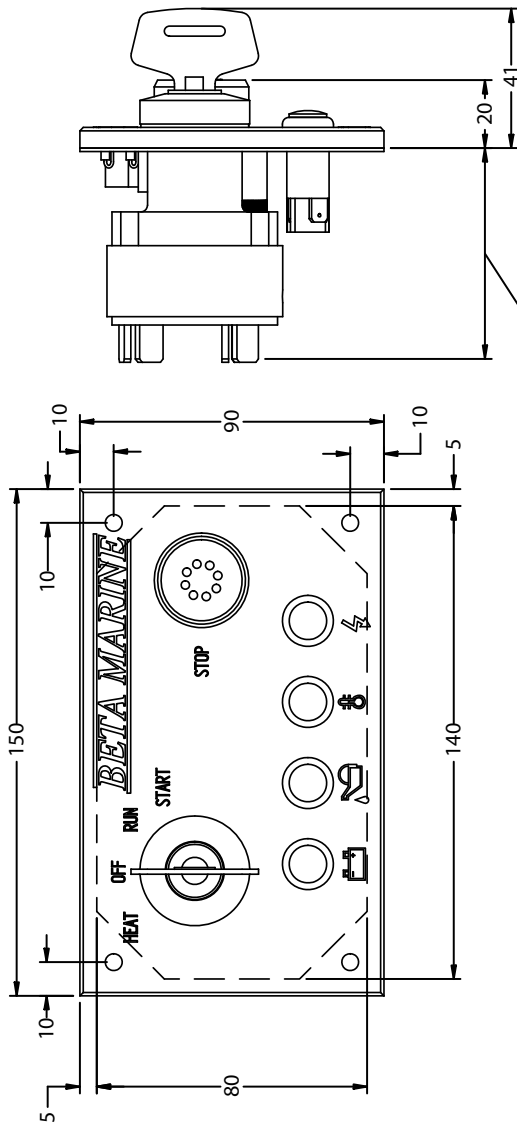

62 ADD 30mm FOR WIRES

REV	DESCRIPTION	DATE	APPD	DRAWN	NOTES	TITLE			
01	CHANGED KEY SWITCH	05/09/08	LT	TW		A PANEL			
						DRAWN BY:	SIZE	DWG NO.	REV
						TW	A4	200-06305	01
						CHECKED BY:	SCALE	NTS	DATE
						LT	LT	2 of 2	05/09/2008
						BETA MARINE LTD. DAVY WAY, WATERWELLS, QUEDGELEY, GLOUCESTER GL2 2AD UK			
						MATERIAL:			
						<b>BETA MARINE</b> TEL +44 (0)1452 723492 FAX +44 (0)1452 883742 <small>DIMENSIONS IN MM (INCH) DO NOT SCALE</small>			

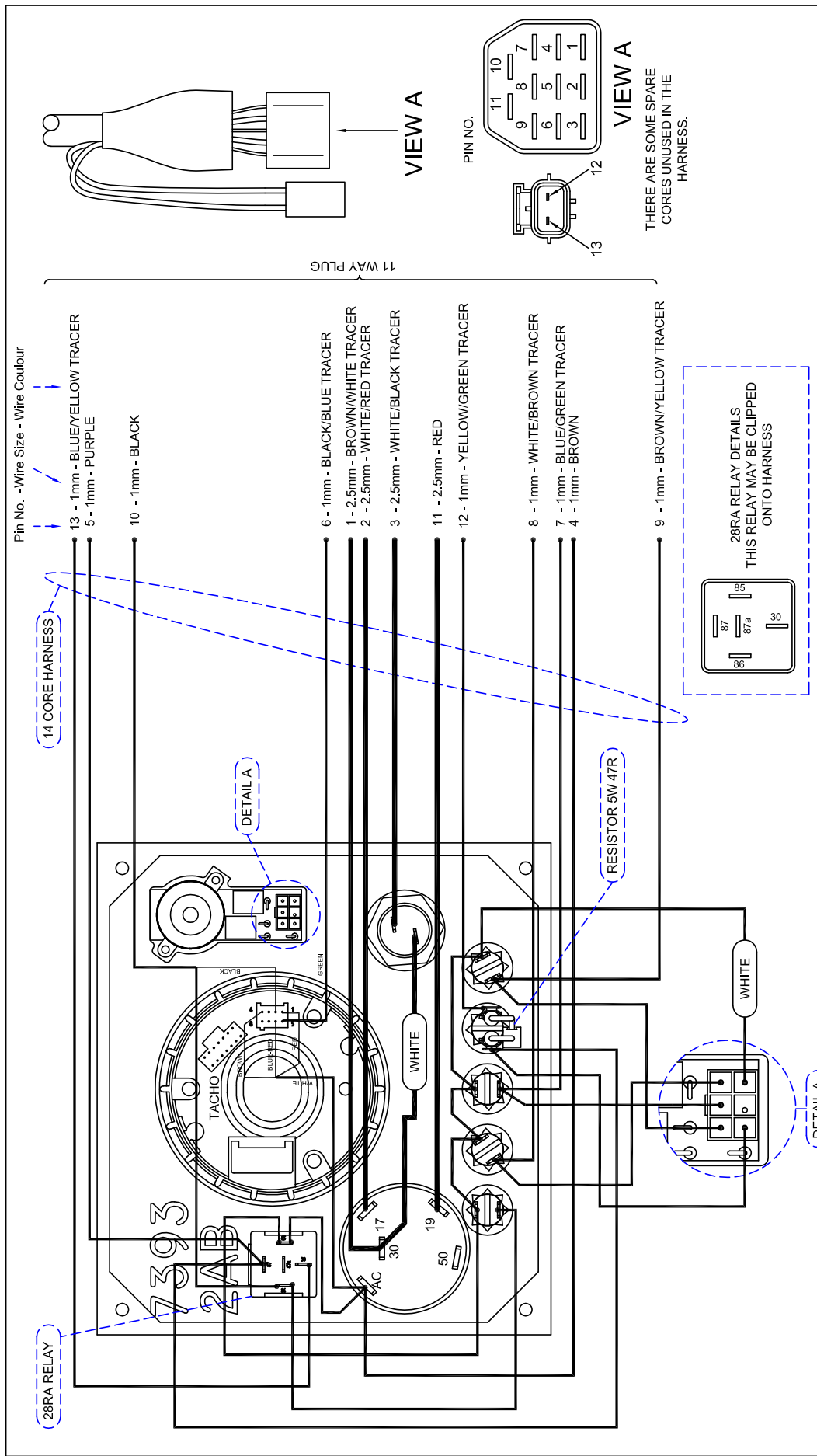

REV	DESCRIPTION	DATE	APP'D	DRAWN	NOTES
01	TACHO AND DOMESTIC WIRING	22/04/11	DM	TW	

<b>TITLE</b> WIRING SCHEMATIC FOR AB PANEL AFTER MAY 2011			
FOR PART LIST AND PANEL SIZE SEE DRAWING 200-06304 PANEL PART NUMBER 200-00850 (THIS EXCLUDES TACHO)		DIMENSIONS IN MM (INCH) DO NOT SCALE	
DRAWN BY:- TW CHECKED BY:- DM	SIZE A4 SCALE N/A	DWG NO. 200-06517 PAGE 1 of 1	DATE 22/04/11 REV 01
BETA MARINE LTD. DAWY WAY, WATERWELLS, QUEDGELEY, GLOUCESTER GL2 2AD UK TEL +44 (0)1452 723492 FAX +44 (0)1452 883742			



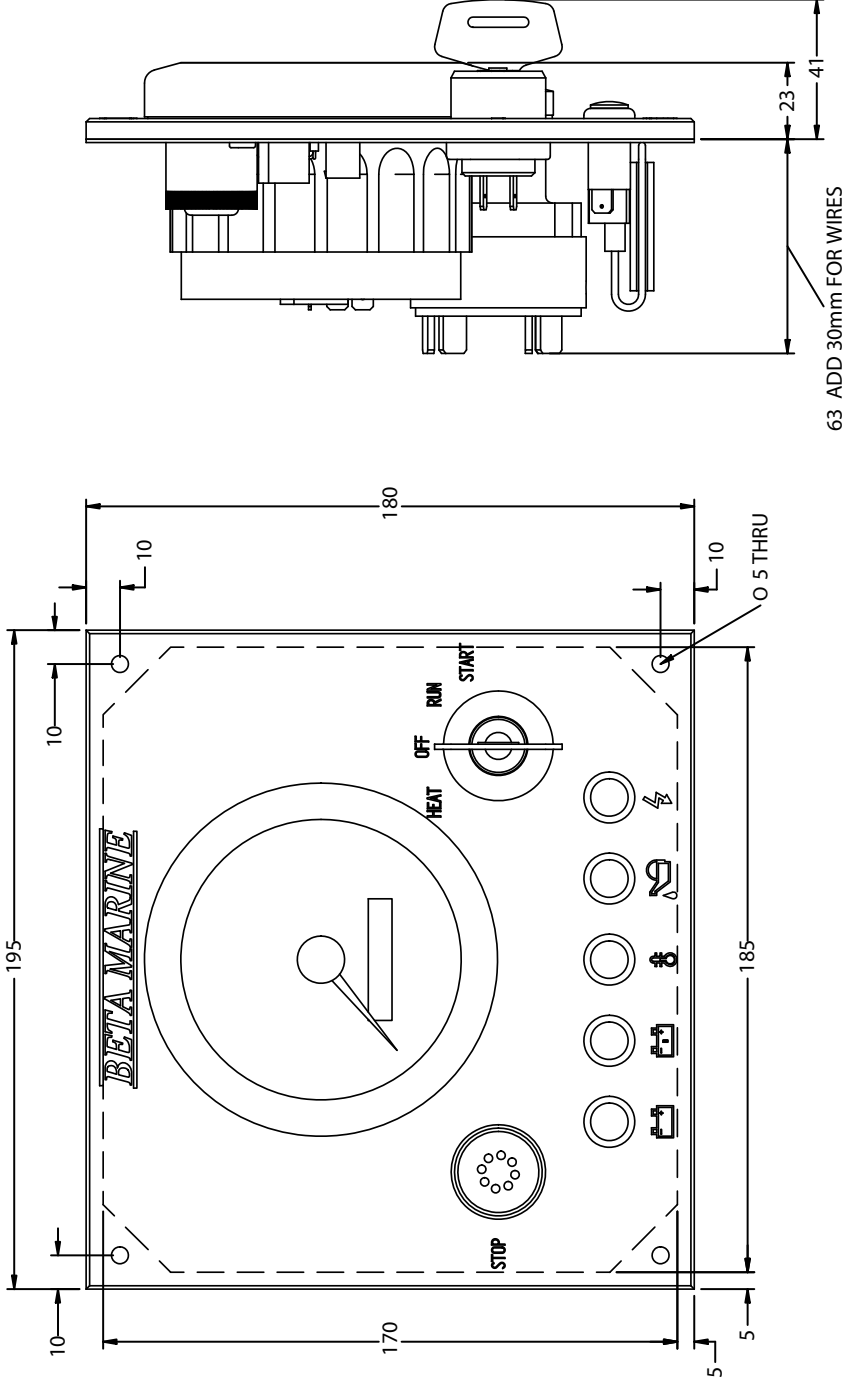

TITLE AB PANEL

REV	DESCRIPTION	DATE	APPD	BY	NOTES						
01	CHANGED KEY SWITCH	05/09/08	LT	TW							
						<p style="text-align: center;">DIMENSIONS IN MM (INCH) DO NOT SCALE</p>					
						<p style="text-align: center;"> <b>BETA MARINE</b> BETA MARINE LTD. DAVY WAY, WATERWELLS, QUEDGELEY, GLOUCESTER GL2 2AD UK TEL +44 (0)1452 723492 FAX +44 (0)1452 883742</p>					
		DRAWN BY:	TW	DWG NO.	200-06304	SCALE	NTS	PAGE	2 of 2	DATE	05/10/2007
		CHECKED BY:	LT	SIZE	A4	REV	01				

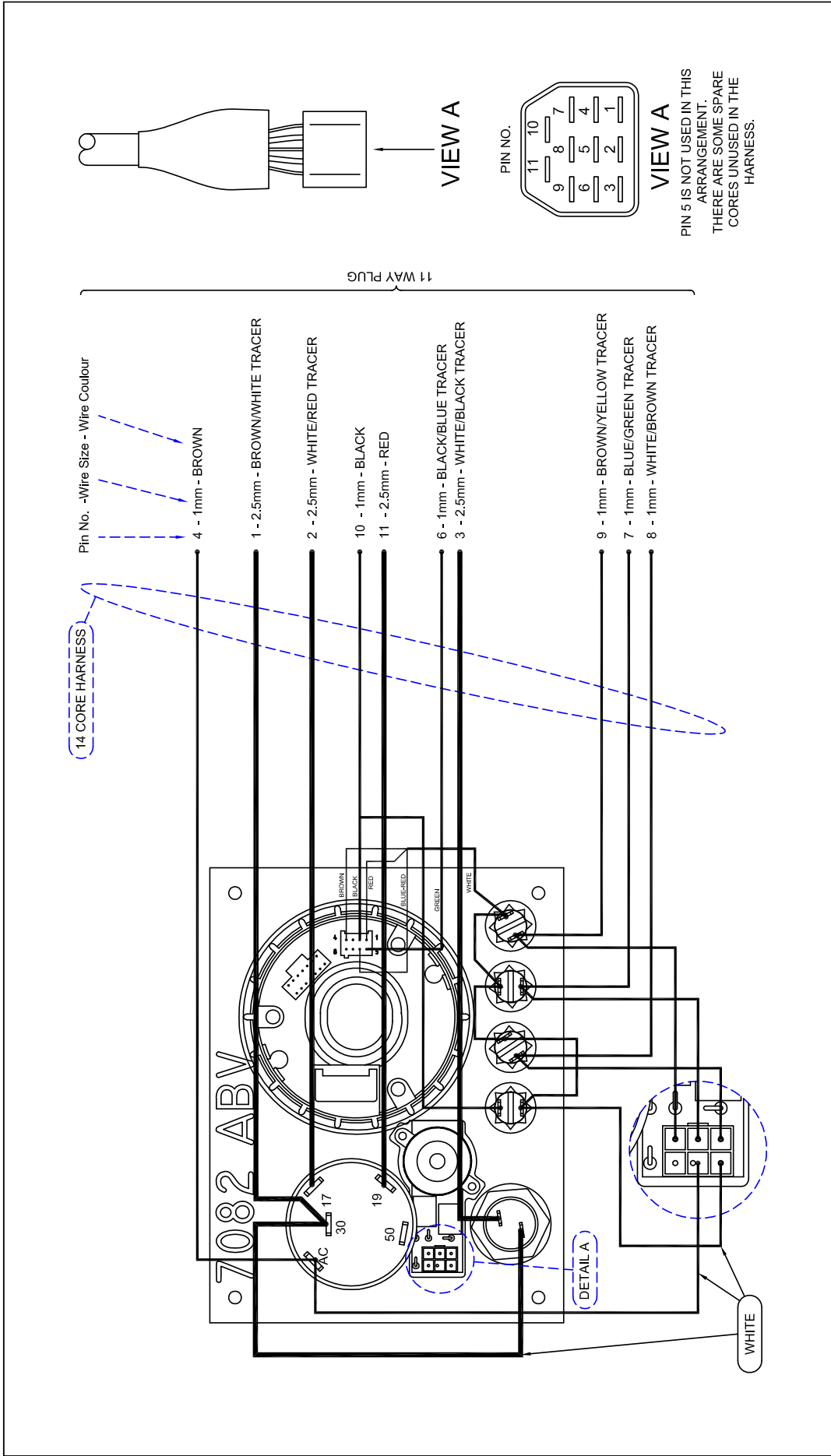

REV	DESCRIPTION	DATE	APP'D	DRAWN	NOTES	TITLE
01	TACHO	22/04/11	DM	LT#:	FOR PART LIST AND PANEL SIZE SEE DRAWING 200-06320 PANEL PART NUMBER 200-89421 THIS EXCLUDES TACHO	WIRING SCHEMATIC FOR ABV PANEL AFTER MAY 2011

SIZE A4	DWG NO. 200-06519	REV 01
SCALE N/A	PAGE 1 of 1	DATE 22/04/11
DRAWN BY:- TW	CHECKED BY:- DM	
DIMENSIONS IN MM (INCH) DO NOT SCALE BETA MARINE LTD. DAVY WAY WATERWELLS, QUEDGELEY GLOUCESTER GL2 2AD UK TEL +44 (0)1452 723492 FAX +44 (0)1452 883742		

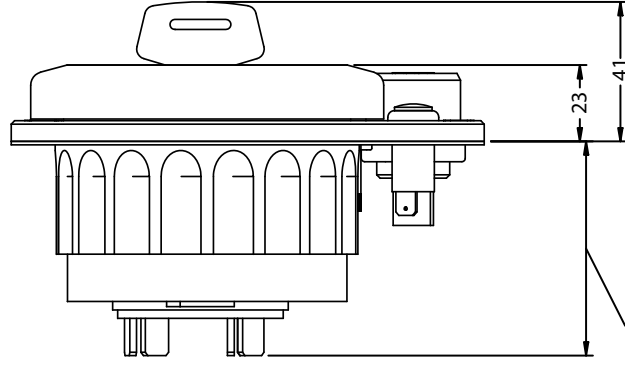
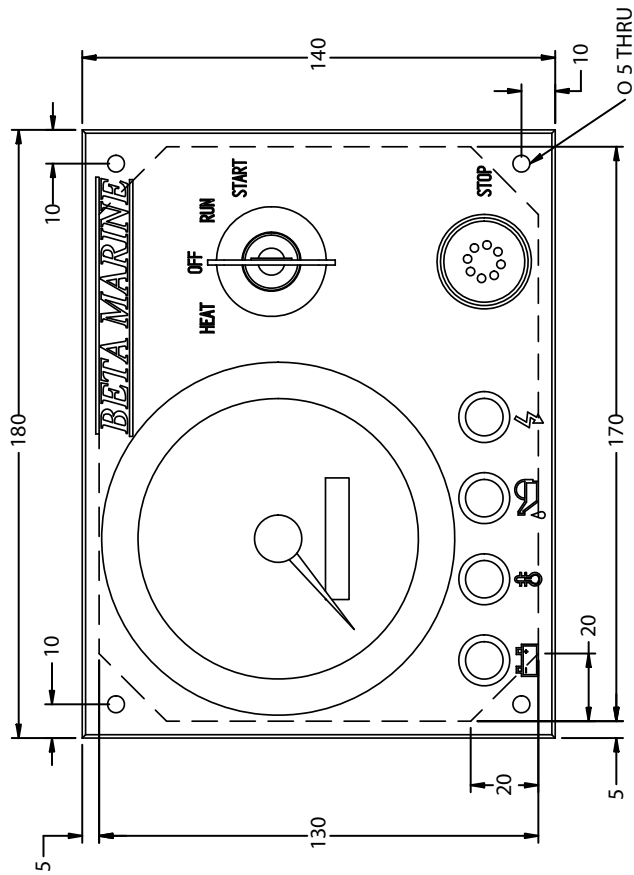

63 ALLOW 30mm FOR WIRES

REV	DESCRIPTION	DATE	APPD	DRAWN	NOTES	TITLE
01	CHANGED KEY SWITCH	05/09/08	LT	TW		ABV PANEL

 <b>BETA MARINE</b>		DIMENSIONS IN MM (INCH) DO NOT SCALE	
BETA MARINE LTD, DAYWAY WATERWELLS, QUEDSELEY, GLOUCESTER GL2 2ND UK		DRAWN BY: <b>timw</b>	DWG NO. <b>200-06320/01</b>
CHECKED BY: <b>LT</b>	SCALE <b>LT</b>	NTS <b>2 of 2</b>	DATE <b>05/10/2007</b>
TEL +44 (0)1452 723492	FAX +44 (0)1452 883742	REV <b>00</b>	DATE <b>05/10/2007</b>

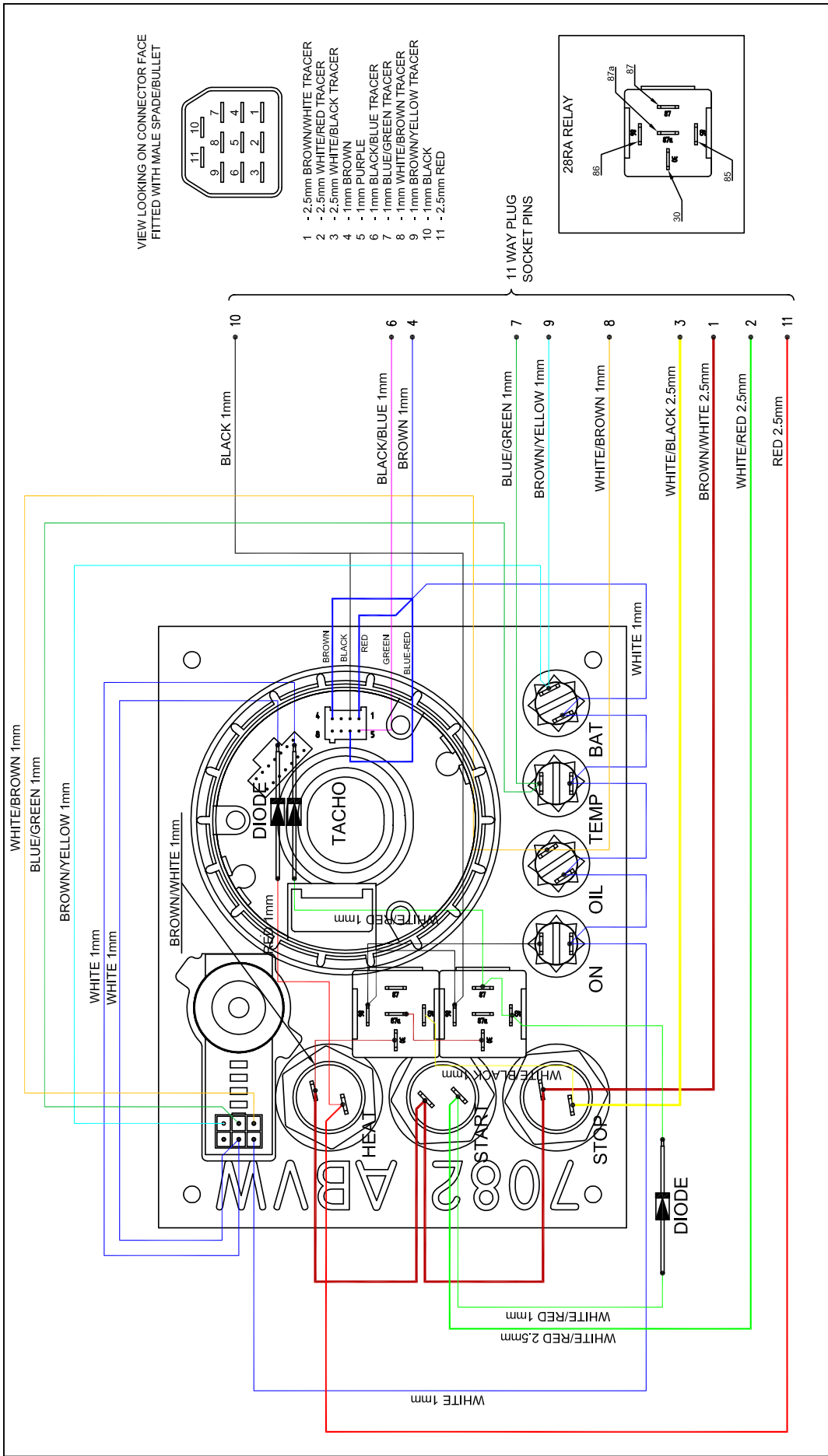

REV	DESCRIPTION	DATE	APP'D	DRAWN	NOTES	TITLE	SCALE	N/A	PAGE	1 of 1	DATE	03/12/04	
01	WIRE COLOURS	15/10/04	DM	TW		WIRING SCHEMATIC FOR ABVV PANEL	A4						
02	MOVED BROWN/YELLOW WIRE	20/01/06	DM	TW			DM						
03	TACHO	22/04/11	DM	TW			DM						
DIMENSIONS IN MM (INCH) DO NOT SCALE							BETA MARINE LTD. DAVY WAY, WATERWELLS, QUEDGELEY, GLOUCESTER GL2 2AD UK TEL +44 (0)1452 723492 FAX +44 (0)1452 883742						
DRAWN BY:-- TW CHECKED BY:-- DM							DWG NO. 100-06333 SCALE N/A PAGE 1 of 1 DATE 03/12/04						

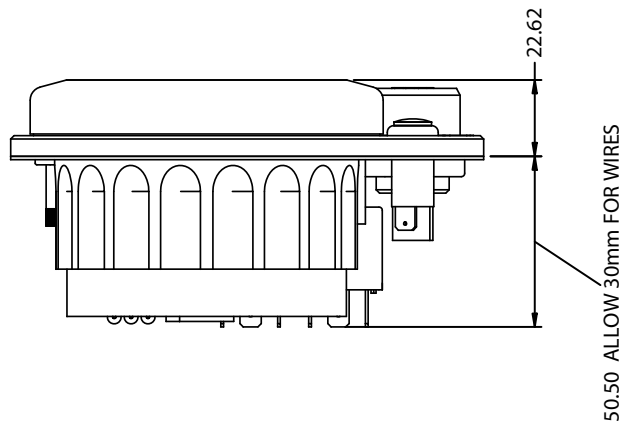
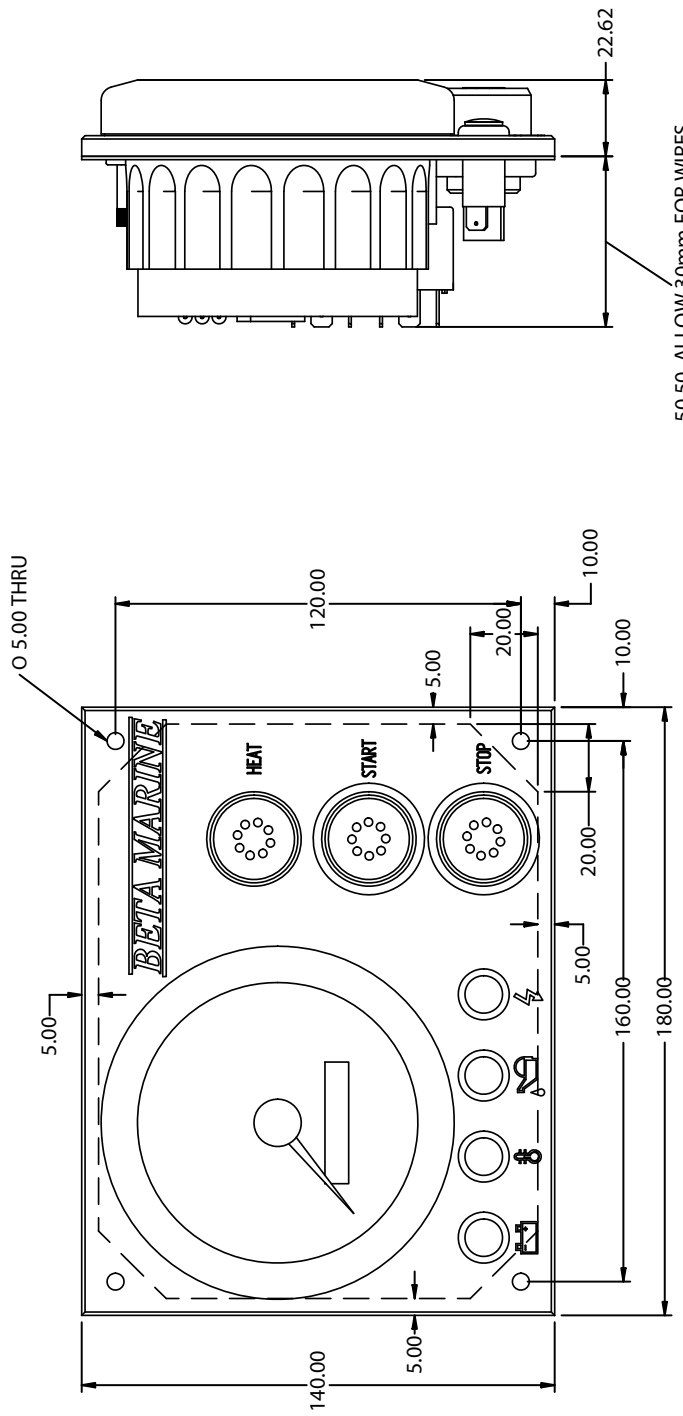

REV	DESCRIPTION	DATE	APPD	DRAWN
01				

NOTES		DRAWN BY:		CHECKED BY:	
AS USED ON K14744		TW		LT	
BETA MARINE LTD. DANY WAY, WATERWELLS, QUEDGELEY, GLOUCESTER GL2 2AD UK					

TITLE ABWW SPLASH PROOF PANEL					
SIZE	DWG NO.	SCALE	PAGE	REV	
A4	200-06331	LT	2 of 2	00	
DATE			05/10/2007		

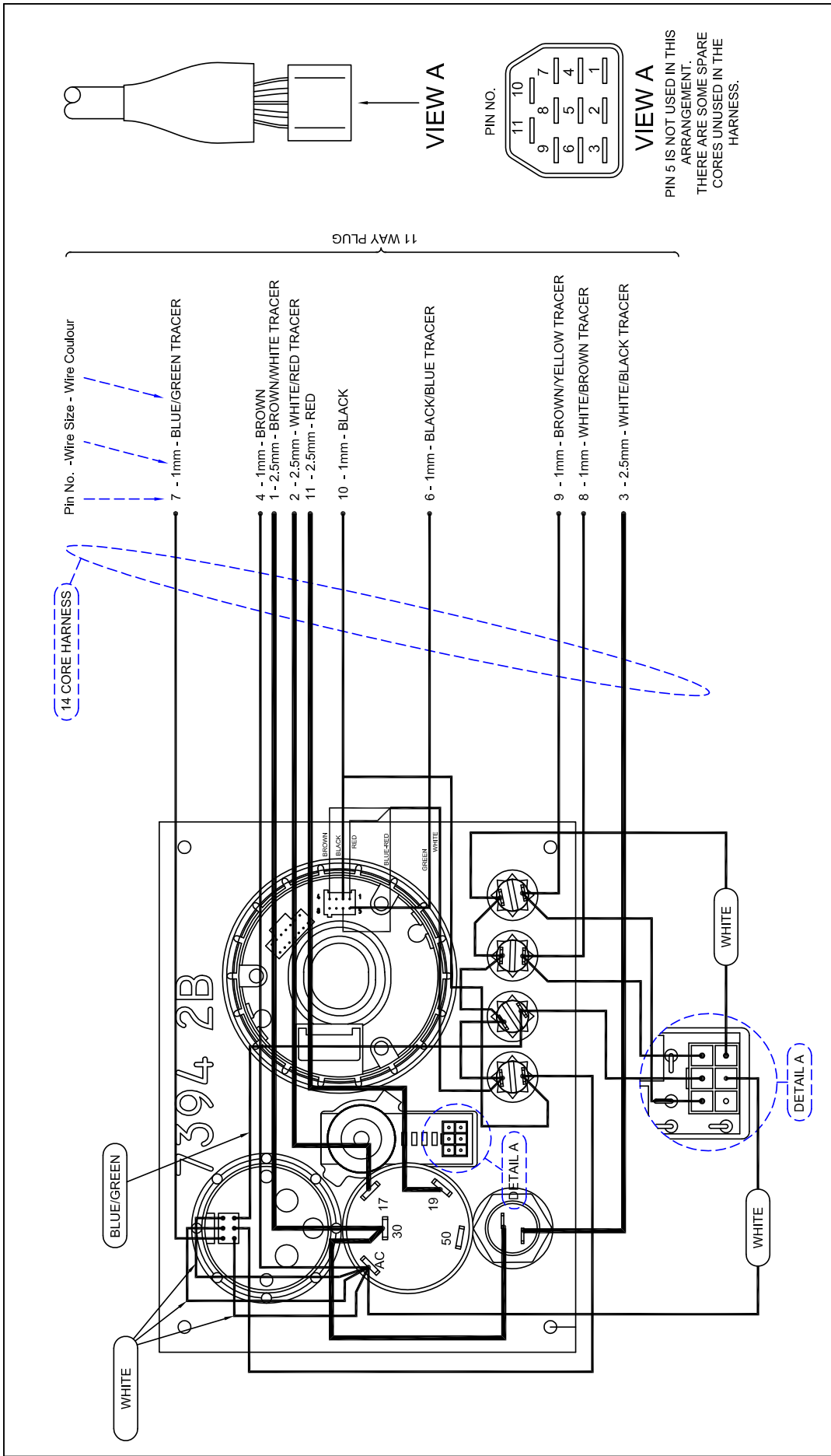

REV	DESCRIPTION	DATE	APP'D	DRAWN	NOTES	TITLE	SCALE	N/A	PAGE	1 of 1	DATE	16/05/05
01	TACHO	22/04/11	DM	TW		WIRING SCHEMATIC FOR B PANEL AFTER MAY 2011	A4		N/A	1	DATE	REV
												01

DIMENSIONS IN MM (INCH)  
DO NOT SCALE

BETA MARINE LTD.  
DAVY WAY, WATERWELLS  
QUEDGELEY, GLOUCESTER  
GL2 2AD UK

TEL +44 (0)1452 723492 FAX +44 (0)1452 883742

BETA MARINE

DRAWN BY:- TW  
CHECKED BY:- DM  
DWG NO. 200-06520

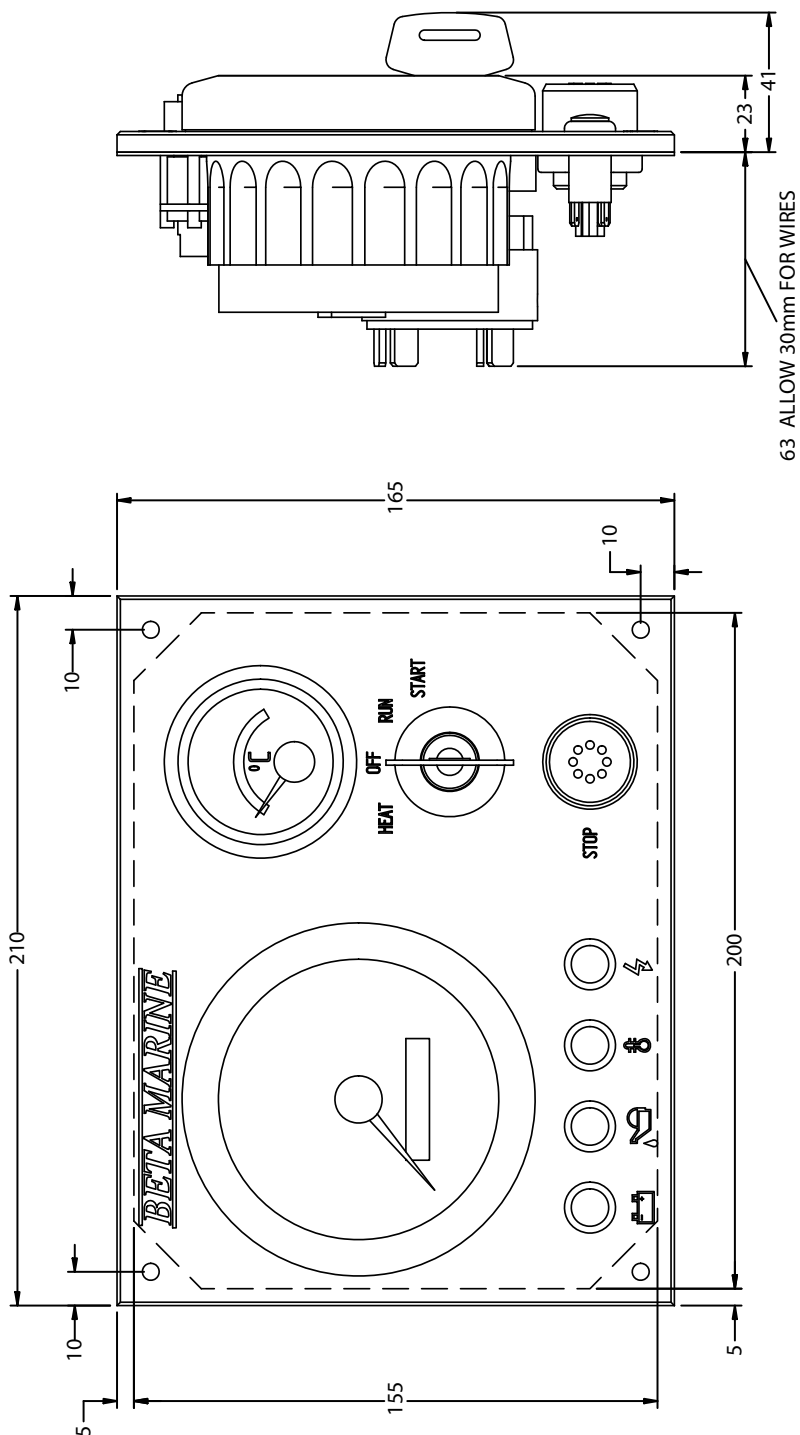

REV	DESCRIPTION	DATE	APPD	DRAWN	TITLE					
01	CHANGED KEY SWITCH	05/09/08	LT	TW	B PANEL					
NOTES					DRAWN BY:	DWG NO.	REV	SCALE	PAGE	DATE
DIMENSIONS IN MM (INCH) DO NOT SCALE					TW	200-06303	01	LT	2 of 2	05/10/2007
MATERIAL:					CHECKED BY:	BETA MARINE LTD. DAY V WAY, WATERWELLS, QUEDGELEY, GLOUCESTER GL2 2AD UK				
					TEL +44 (0)1452 723492 FAX +44 (0)1452 883742		NITS			

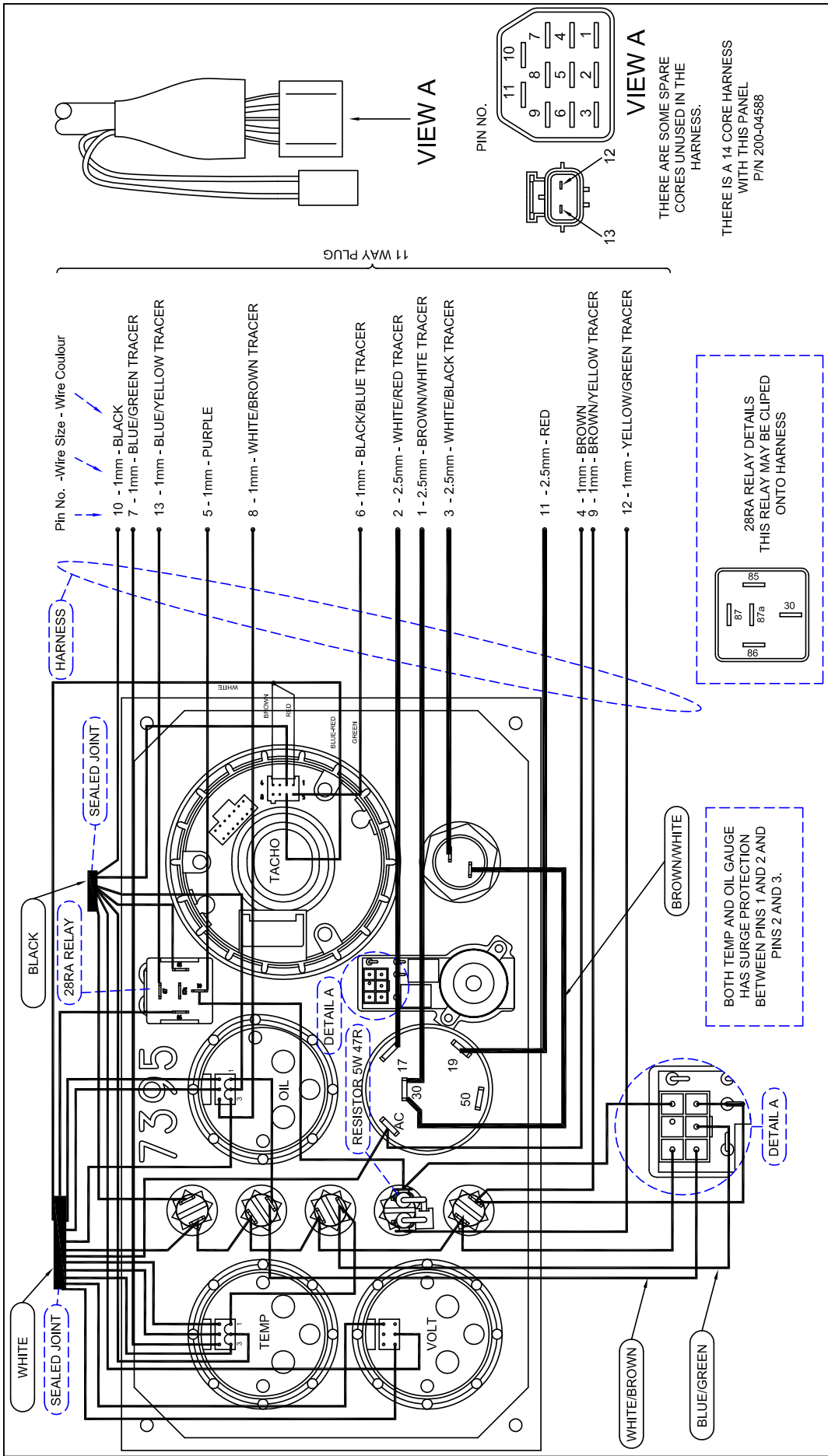

REV	DESCRIPTION	DATE	APP'D	DRAWN	NOTES
01	CHANGED WHITE & BLACK AROUND	19/09/05	DM	TW	
02	TACHO AND DOMESTIC WIRES	22/04/11	DM	TW	

  

TITLE		DRAWN BY:-		CHECKED BY:-	
WIRING SCHEMATIC FOR C PANEL (DELUXE) AFTER MAY 2011		TW		DM	
FOR PART LIST AND PANEL SIZE SEE DRAWING 200-06306 PANEL PART NUMBER 200-05445 (THIS EXCLUDES GAUGES)		DRAWN BY:-		CHECKED BY:-	
DIMENSIONS IN MM (INCH) DO NOT SCALE		SCALE		PAGE	
BETA MARINE LTD. DAY VAY WATERWELLS, QUEDGELEY, GLOUCESTER GL2 2AD UK		SIZE A4		N/A	
TEL +44 (0)1452 723492 FAX +44 (0)1452 883742		DWG NO. <b>200-06518</b>		DATE 15/05/05	
		1 of 1		REV 02	



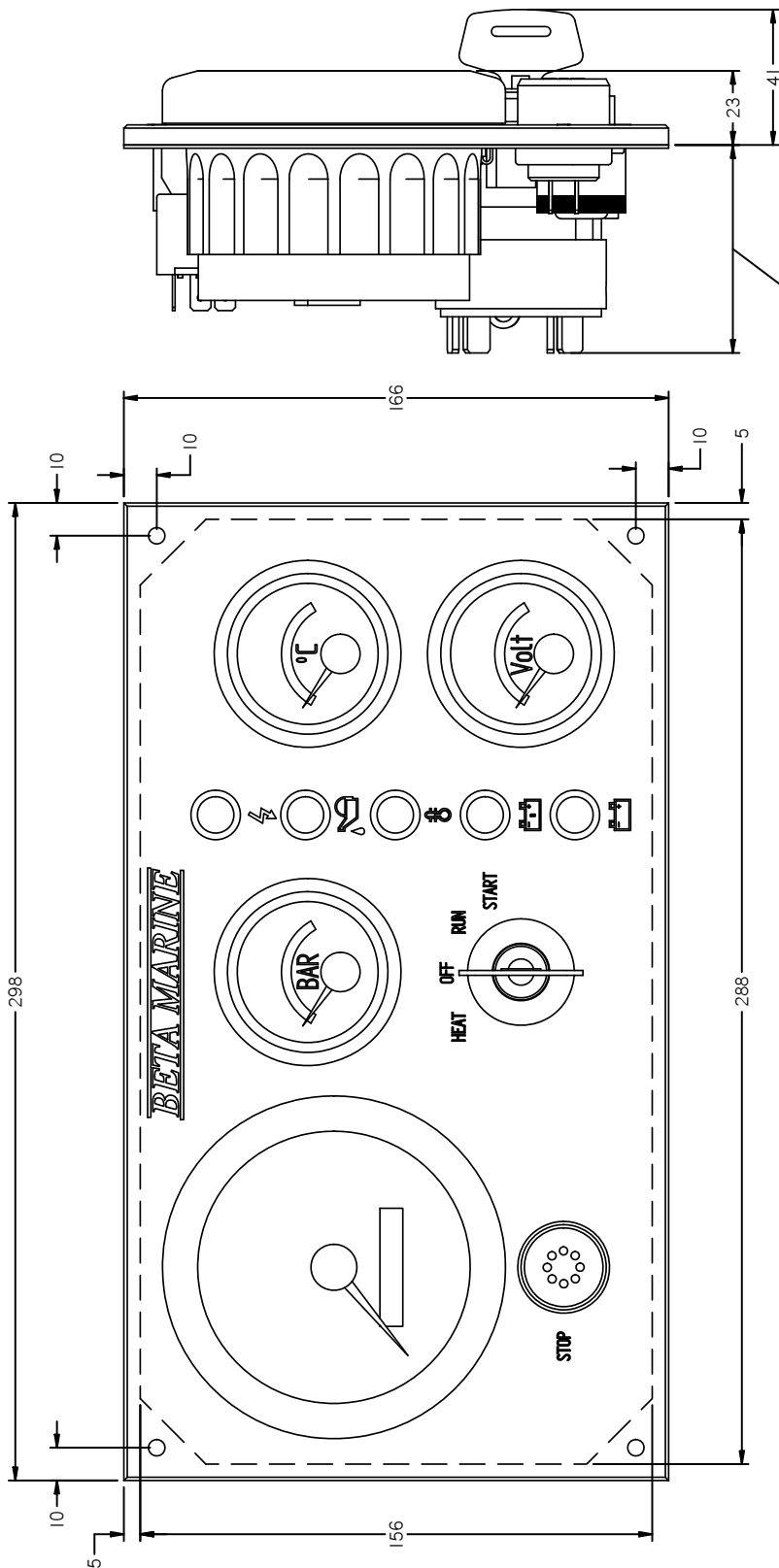

REV	DESCRIPTION	DATE	APP'D	DRAWN	NOTES	TITLE				
01	CHANGED KEY SWITCH	05/09/08	LT	TW		C PANEL				
						DIMENSIONS IN MM (INCH) DO NOT SCALE <b>BETA MARINE</b> MATL: BETA MARINE LTD, DAVEY WAY, WATERMILLS, QUEDGELEY, GLOUCESTER, GLE, PA6, U.K. TEL: (01453) 835282 FAX: (01453) 835284				
						SIZE	DWG NO.	REV	SCALE	DATE
						A4	200-06306	01	2 of 2	05/10/2007
						DRAWN BY:-	NTS		PAGE	DATE
						TW				
						CHECKED BY:-				
						LT				

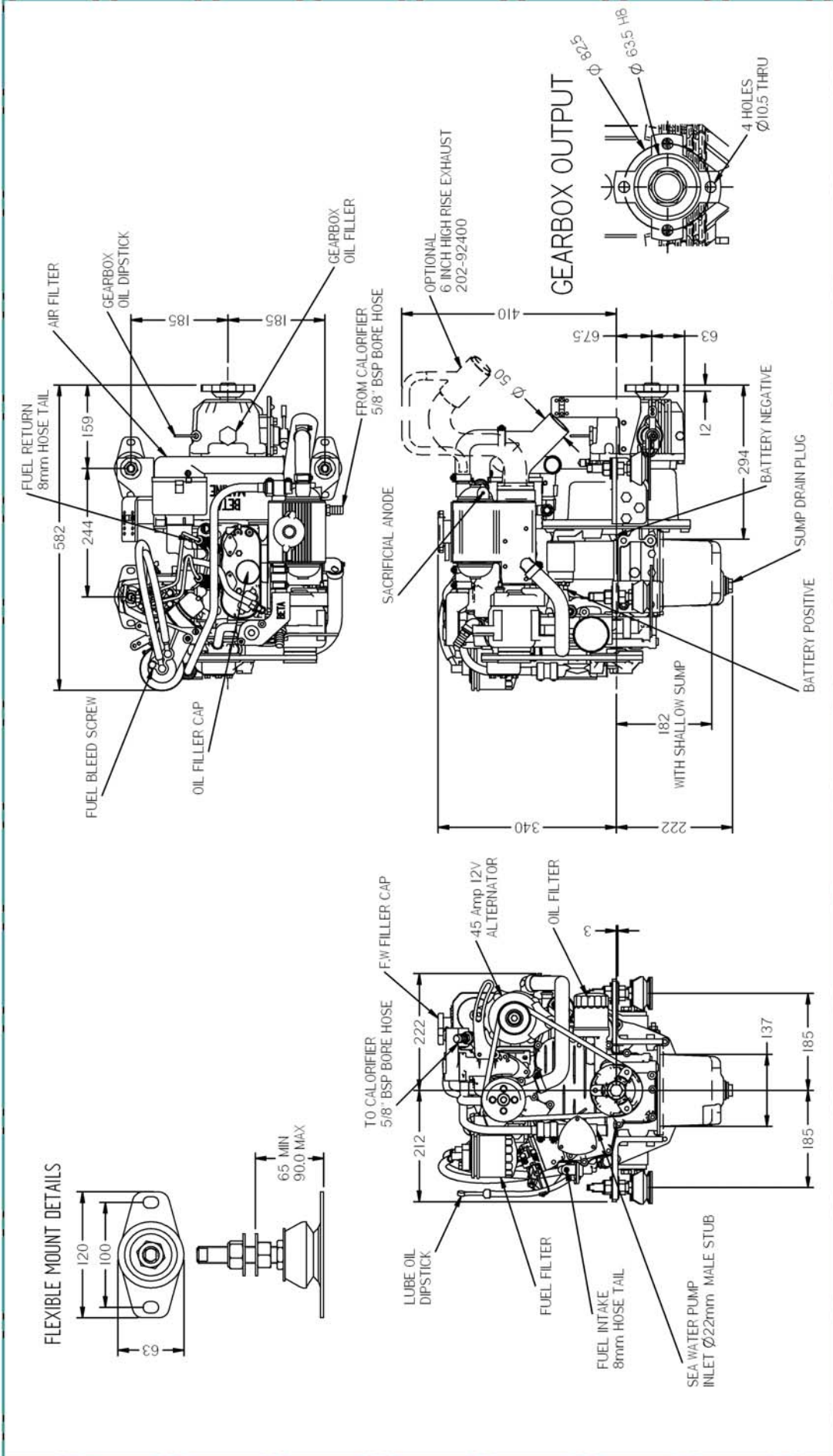

REV			DATE			APPD			DRAWN			NOTES		
01	NEW TITLE BLOCK		5-01-04	LT		TW								
02	UPDATED TO MATCH TIER2 AND FUEL FILTER SYSTEM		20-12-05			TW								

TITLE		BETA 10 HEAT EXCHANGE TMC40 GEARBOX											
DRAWN BY:	TW	SIZE	A4	DWG NO.	100-00030	REV	02						
CHECKED BY:		SCALE	1 of 1	PAGE	1 of 1	DATE	12/08/2009						

 <b>BETA MARINE</b> BETA MARINE LTD. DAVY WAY, WATERWELLS, QUIDDELEY, GLOUCESTER GL2 2AD UK TEL: +44 (0)1452 723492 FAX: +44 (0)1452 883742			
---	--	--	--

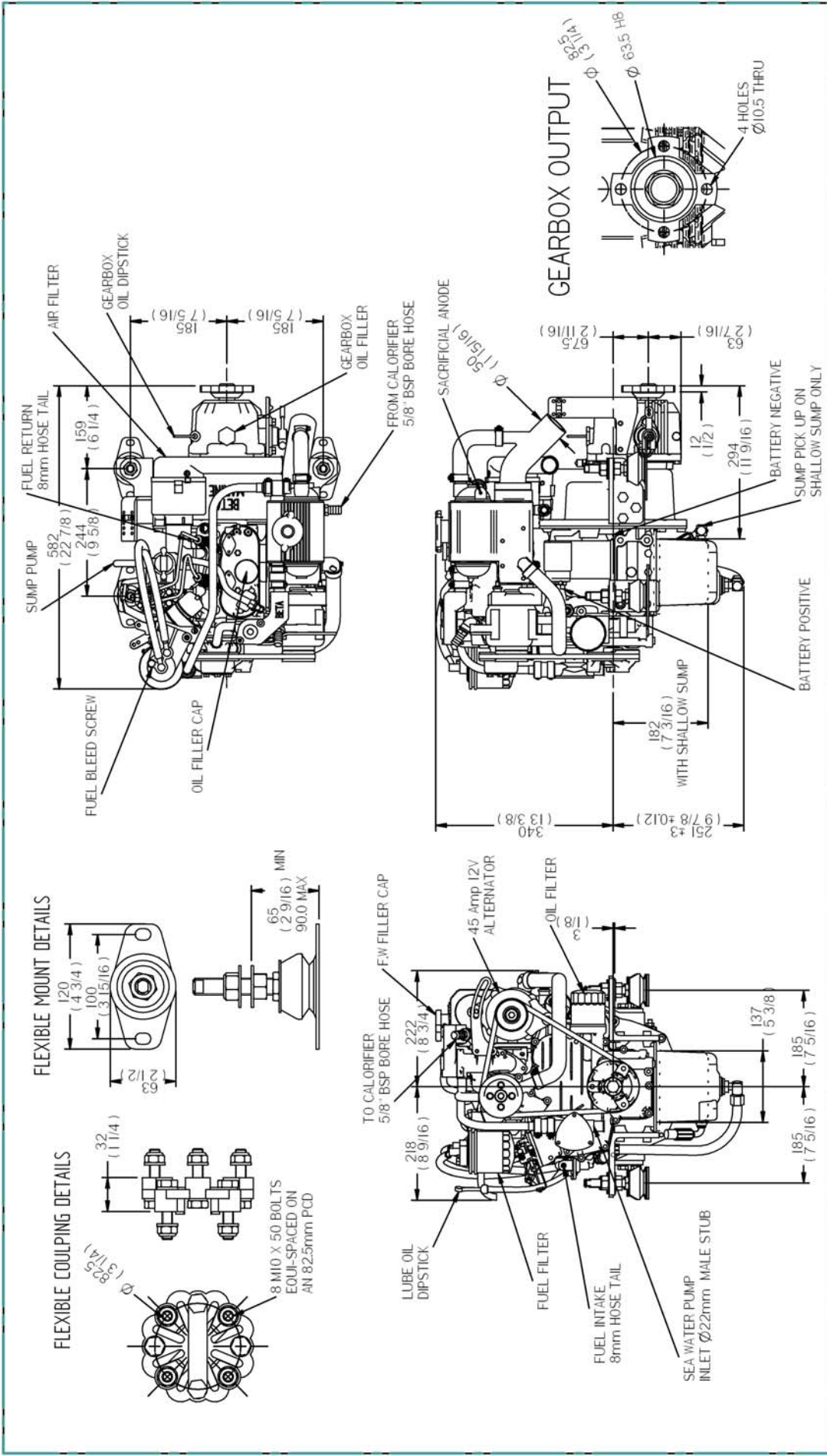

REV	DESCRIPTION	DATE	APPD	DRAWN	NOTES
01	NEW TITLE BLOCK	15-01-04	LT	TW	
02	BATTERY CONNECTIONS AND WASTING ANODE	11-10-04	LT	TW	
03	FUEL FILTER, FHE TANK AND AIR FILTER	25-07-05	LT	TW	
04	CAURIPERS AND TIEZ CLOSED BREATHER	20/12/05		TW	

**BZ482 HEAT EXCHANGE  
TMC40 GEARBOX**

SIZE: A4  
SCALE: 1 of 1  
DATE: 12/08/2009  
REV: 04

BETA MARINE LTD.  
DAILY WAY, WATERWELLS,  
QUEDGELEY, GLOUCESTER  
GL2 2AD UK

BETA MARINE  
TEL: +44 (0)1452 723492 FAX: +44 (0)1452 883742

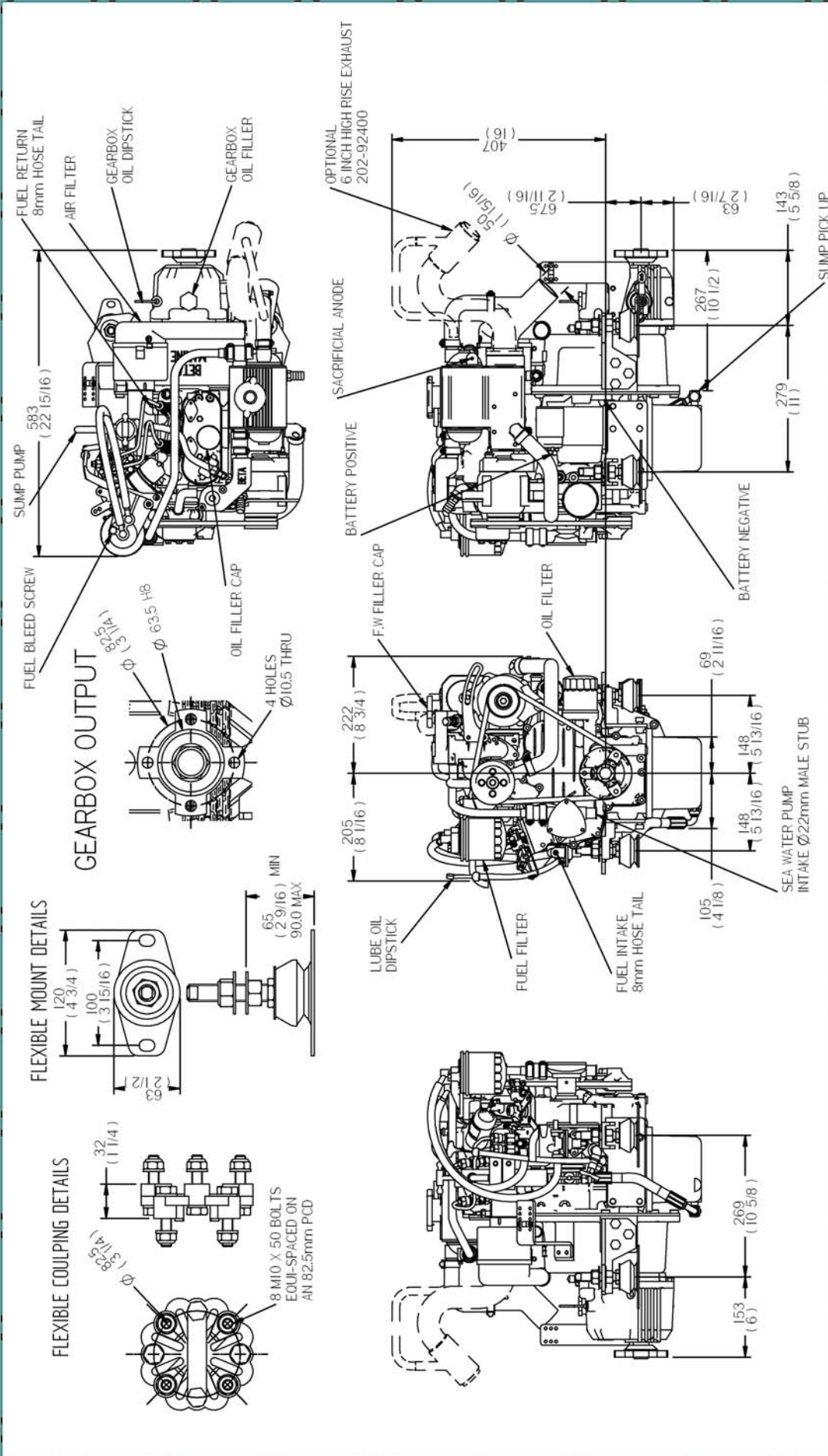

REV	DESCRIPTION	DATE	APPD	DRAWN	NOTES	TITLE
01	FUEL FILTER, FUEL TANK AND AIR FILTER	01/10/01	LT	TW	Measurements are in: mm (Inch to the closest 1/16)	BETA 14 HEAT EXCHANGE TMC40 ATOMIC FEET
02	CALORIFIERS AND TIEZ CLOSD BREATHER	27/03/07	LT	TW		
DIMENSIONS IN MM (INCH) DO NOT SCALE						
MATERIAL: <b>BETA MARINE</b>						
BETA MARINE LTD. DAVY WAY, WATERBURY, GLoucester, GL2 2AD, UK TEL: (01452) 723492 FAX: (01452) 729916						
DRAWN BY: TW		SIZE: A4		DWG NO: 100-01973		REV: 02
CHECKED BY: LT		SCALE: NTS		PAGE: 1 of 1		DATE: 05/10/2007

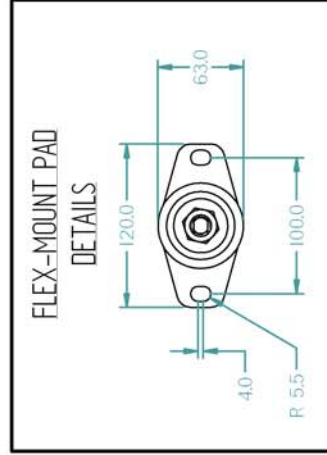
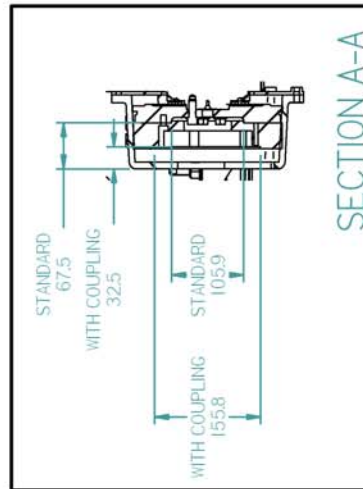
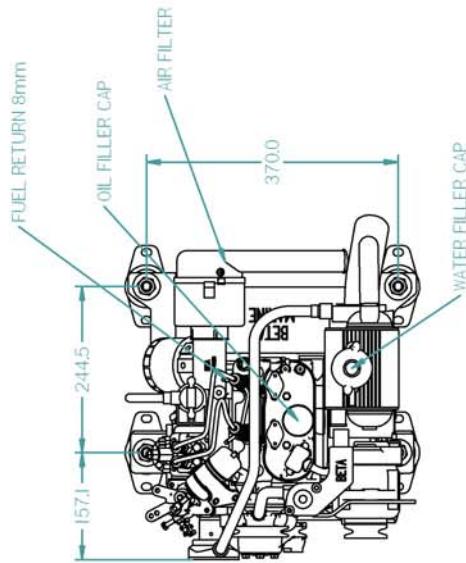
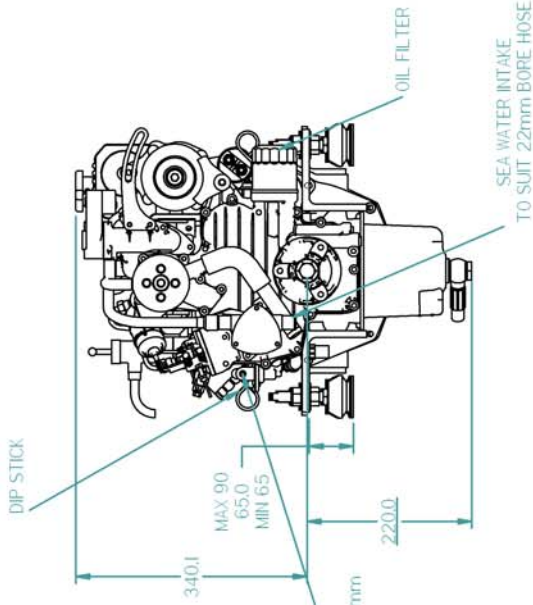
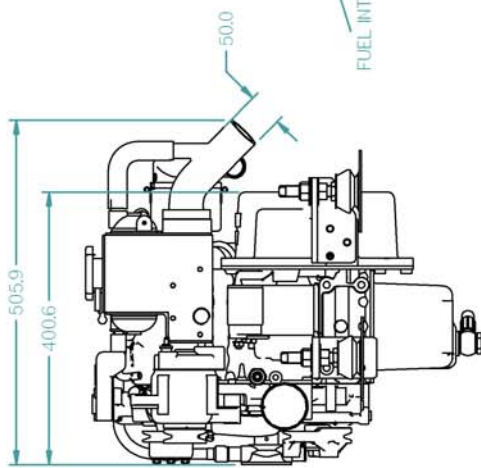
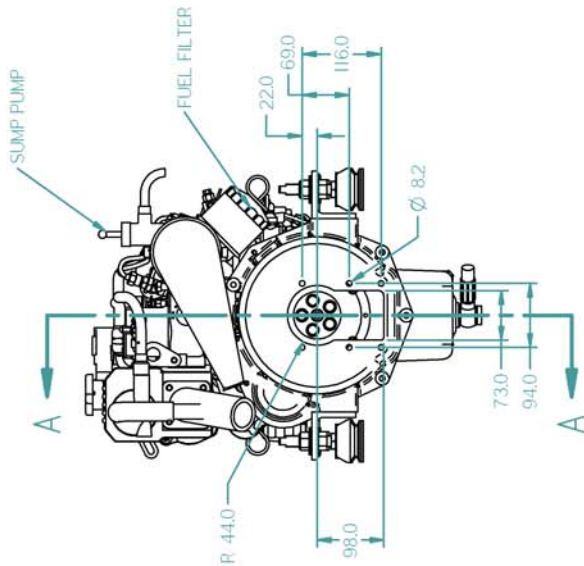

REV	DESCRIPTION	DATE	APPD	DRAWN	NOTES	TITLE
01						BETA 14 HEAT EXCHANGE BOB-TAIL ENGINE
						SCALE: NTS 1 of 1
						DATE: 12/08/2009
						SIZE: A4
						DWG NO: 100-06357
						REV
						DRAWN BY: TW
						CHECKED BY: LT
						BETA MARINE LTD. DAVY WAY, WATERWELLS, QUEDGELEY, GLOUCESTER GL2 2AD UK
						TEL +44 (0)1452 723492 FAX +44 (0)1452 883742

**FLEXIBLE COUPLING  
DETAILS**

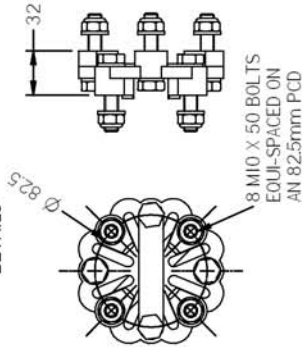

**FLEXIBLE MOUNT DETAILS**

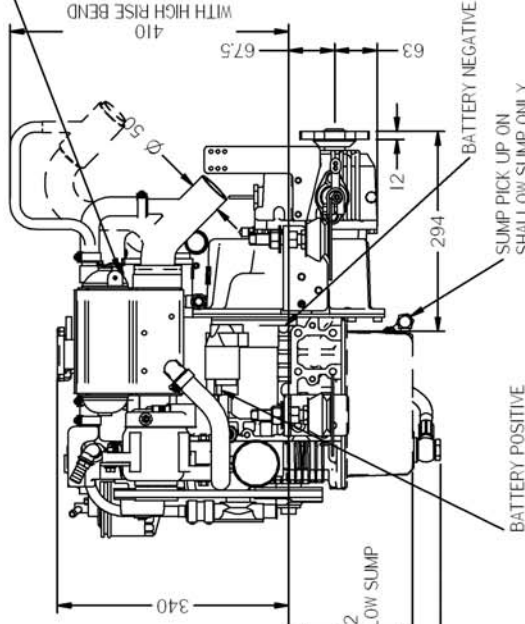
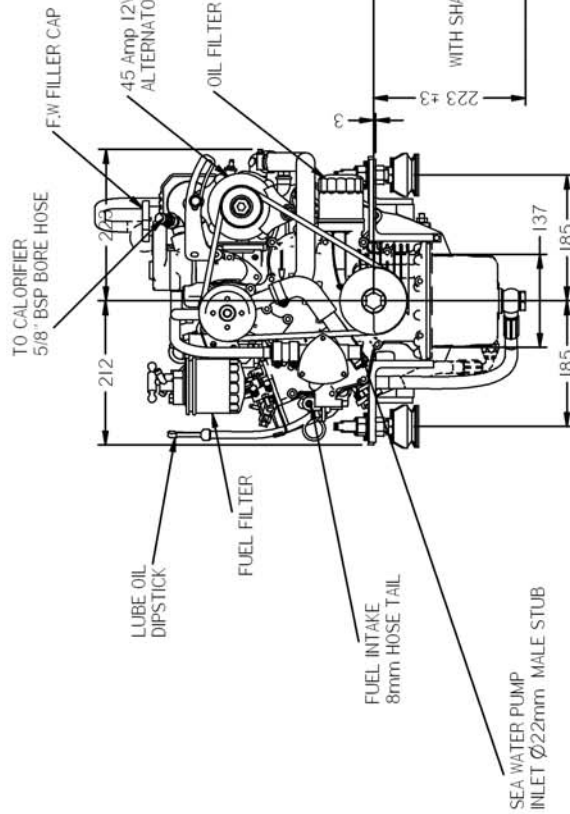
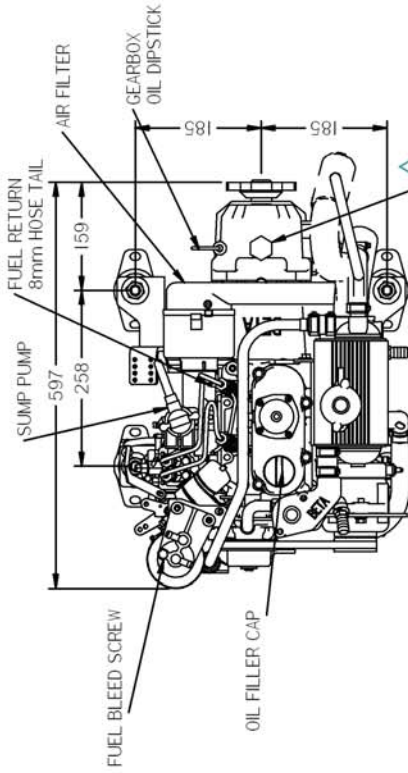
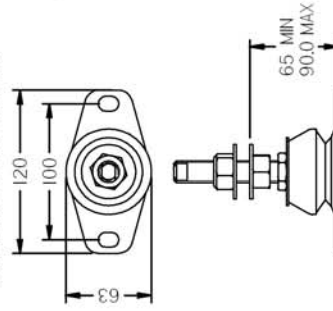

**GEARBOX OUTPUT**

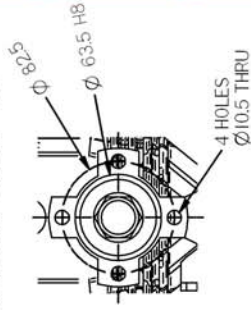

REV	DESCRIPTION	DATE	APP'D	DRAWN	NOTE
V					
U					
T					
S					
R					
Q					
P					
O					
N					
M					
L					
K					
J					
I					
H					
G					
F					
E					
D					
C					
B					
A					

DIMENSIONS IN MM		DRAWN BY: TW		CHECKED BY:	
DIN ORT SCALE		BY: TW		E	
BETA MARINE		BETA MARINE LTD.		GL2 2AD UK	
TEL +44 (0)1452 733492		FAX +44 (0)1452 883742			
		DRAWG. NO. 100-06496		REV. 00	
		PART E		1 of 1	
		DATE 12/08/2009			

**BETA 16 HEAT EXCHANGE  
TMC40 GEARBOX**

FLEXIBLE MOUNT DETAILS

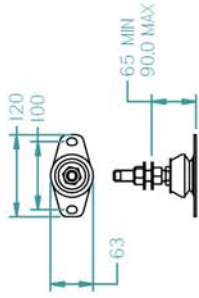

FLEXIBLE COUPLING DETAILS

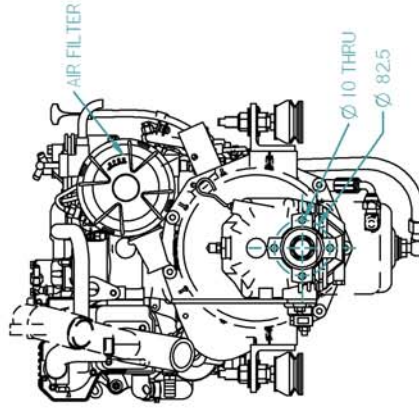
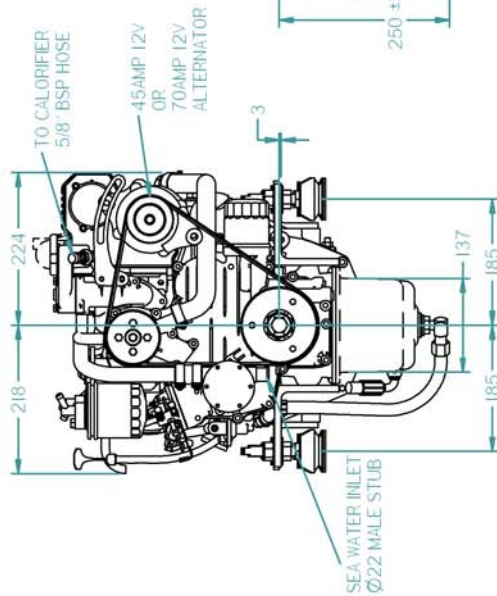
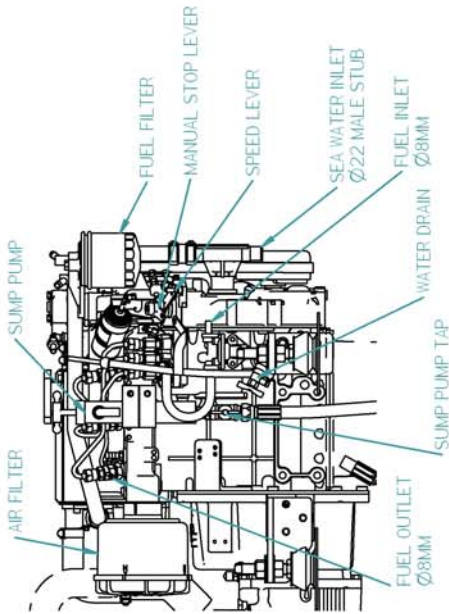
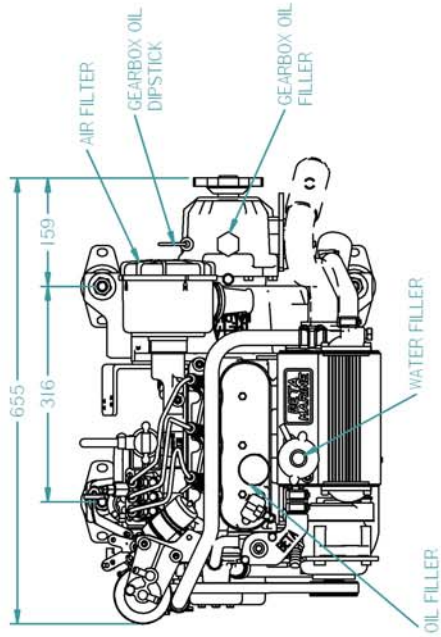
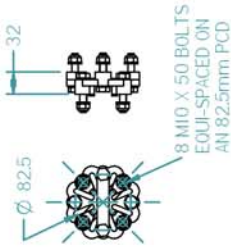

REV	DESCRIPTION	DATE	APPD	DRAWN	NOTES
01					

TITLE:		BD722 HEAT EXCHANGE TMC40 GEARBOX	
DRAWN BY:	SIZE:	DWG NO.:	REV:
TW	A4	100-99610	04
CHECKED BY:	SCALE:	NTS	PAGE:
LT	1 of 1		17/01/2011

DIMENSIONS IN MM (INCH) DO NOT SCALE		PART FILE NAME: 100-99610 04 BD722 HE TMC40 a sm	
<b>BETA MARINE</b>		BETA MARINE LTD. DAVEY WAY, WATERWELLS, QUEDSELEY, GLOUCESTER, GL2 2AD, UK	
TEL: (01452) 723492		FAX: (01452) 729916	

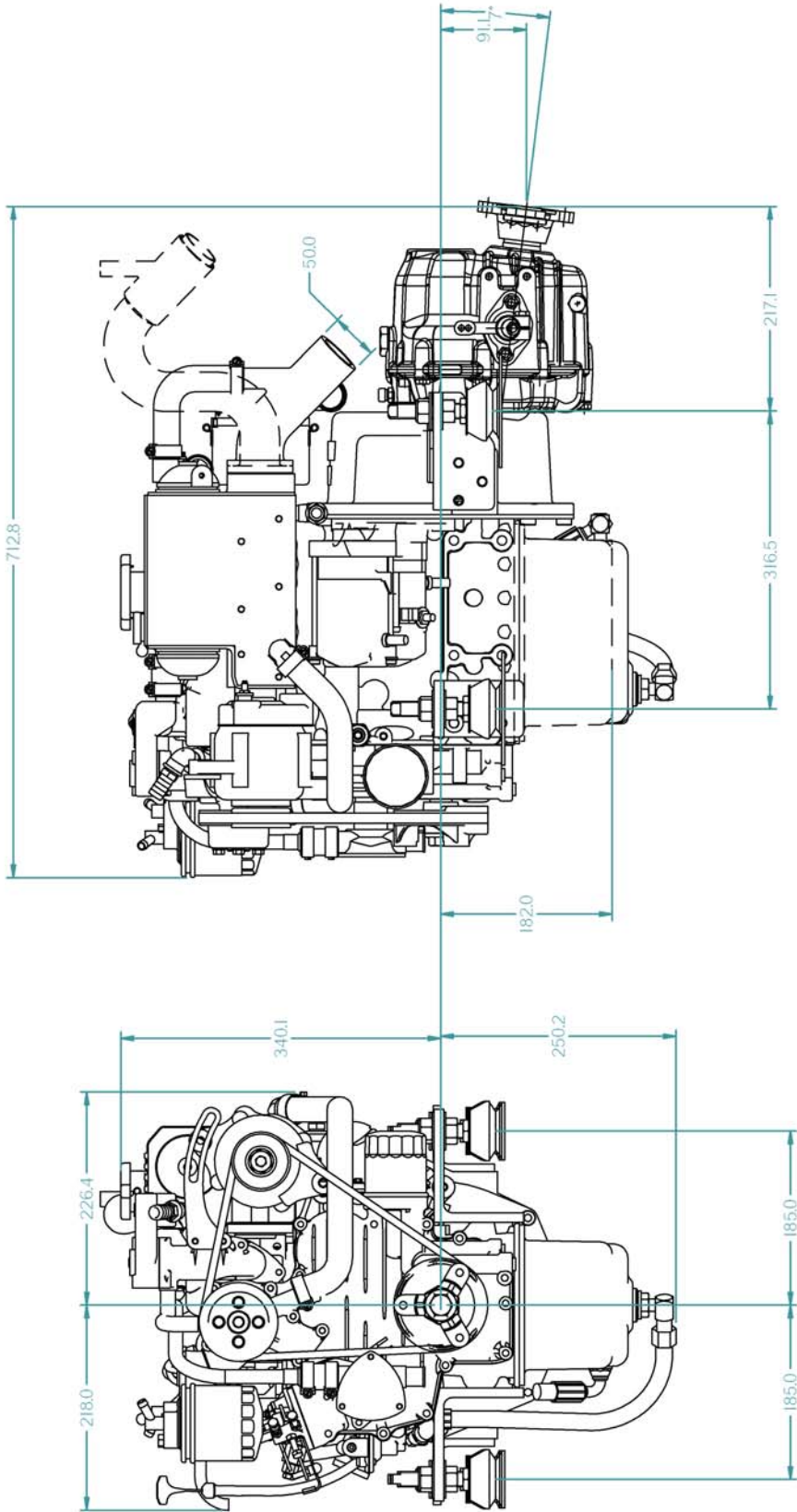

REV	DESCRIPTION	DATE	APPD	DRAWN	MATL	FINISH	UNTOLERANCED DIMS: $\pm 0.25$	TITLE:
01								BETA 20 HEAT EXCHANGE TMC60A GEARBOX

PART FILE NAME: 100-09154_beta20_he_tmc60a.dft				
SCALE: NTS		DATE CREATED: 28/01/2011		
DIMENSIONS IN MM (INCH) DO NOT SCALE				
<b>BETA MARINE</b>				
BETA MARINE LTD. DAVY WAY, WATERWELLS, GLEDDELEY, GLOUCESTERShire, GL2 2AD, UK TEL: (01452) 723492 FAX: (01452) 729916				
DRAWN BY:	TW	SIZE A4	DWG NO:	100-09154
CHECKED BY:	LT	PART NUMBER:		REV 00
				PAGE 1 of 1



FLEXIBLE MOUNT

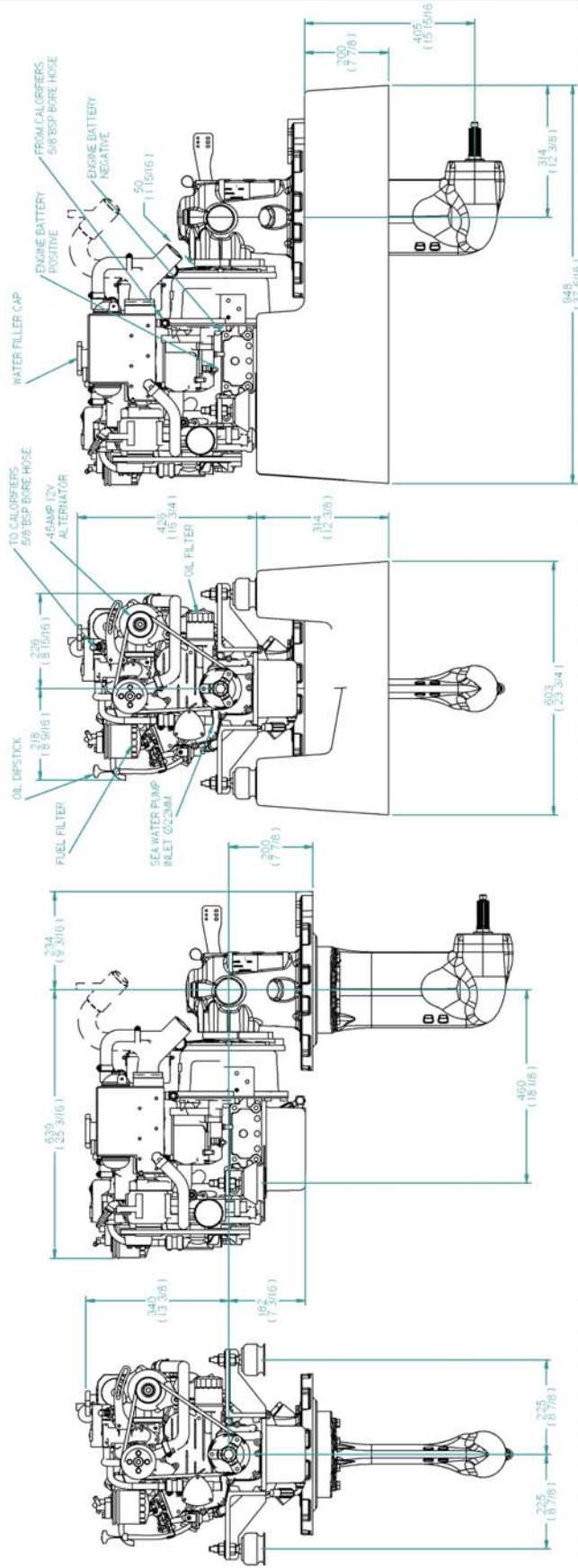
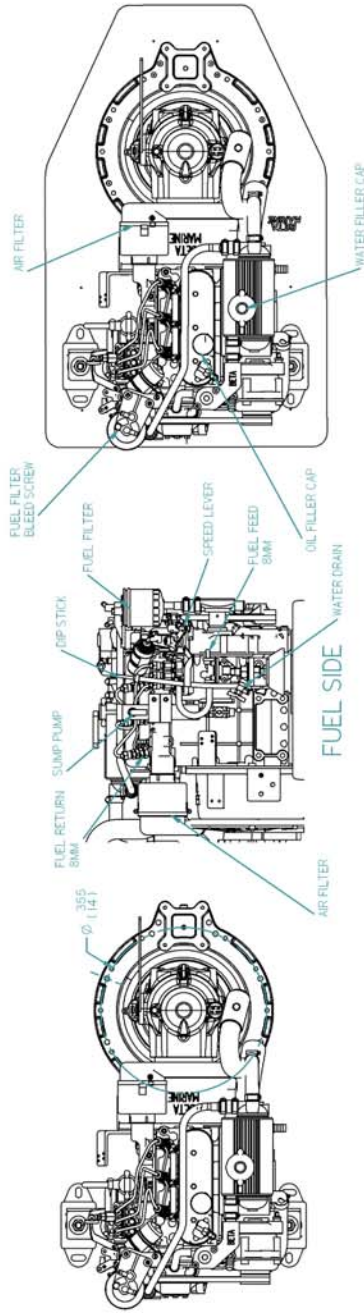
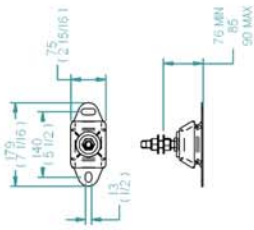

REV	DESCRIPTION	DATE	APP'D	DESIGN

NOTES

TITLE: BETA20 HEAT EXCHANGE SEA PROP 60

ENGINEERING: BETA MARINE  
 DRAWING: TW AS  
 CHECKED BY: LT  
 SCALE: NTS  
 PART FILE NAME: BETA 20 HEAT EXCHANGE SEA PROP 60 100-08836.dwg  
 DRAWING NO: 100-08836  
 REV: 00  
 DATE: 02/12/2010

BETA MARINE  
 TEL: 01443 229918 FAX: 01443 229918  
 BETA MARINE LTD.  
 WATERVILLE  
 GLOUCESTERShire GL2 3JL UK

**FLEXIBLE COUPLING DETAILS**

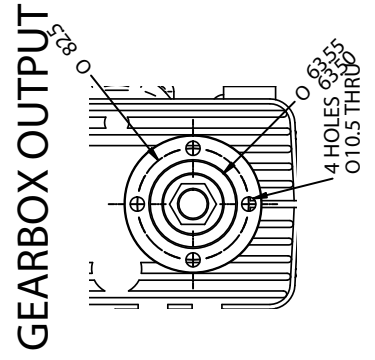
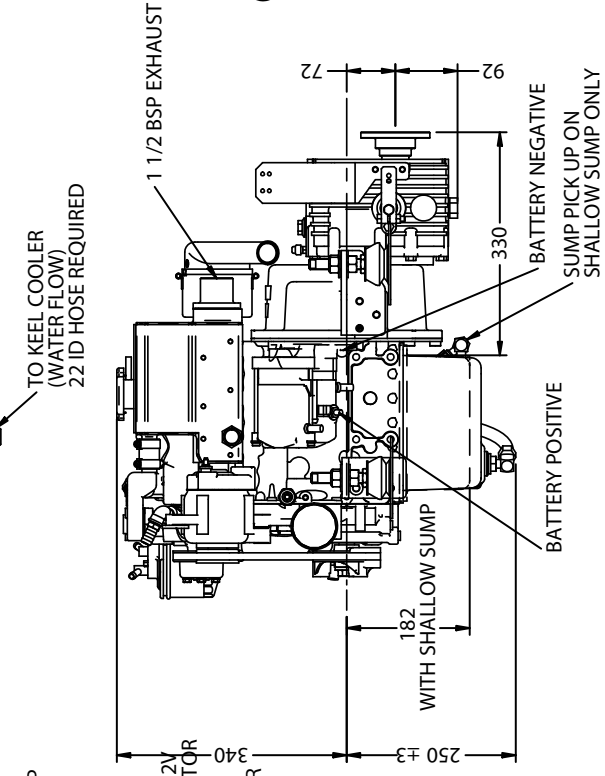
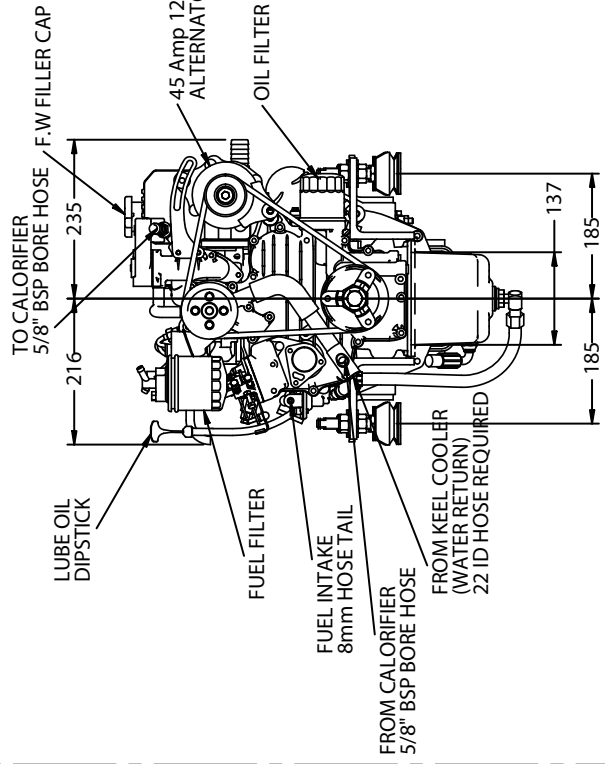
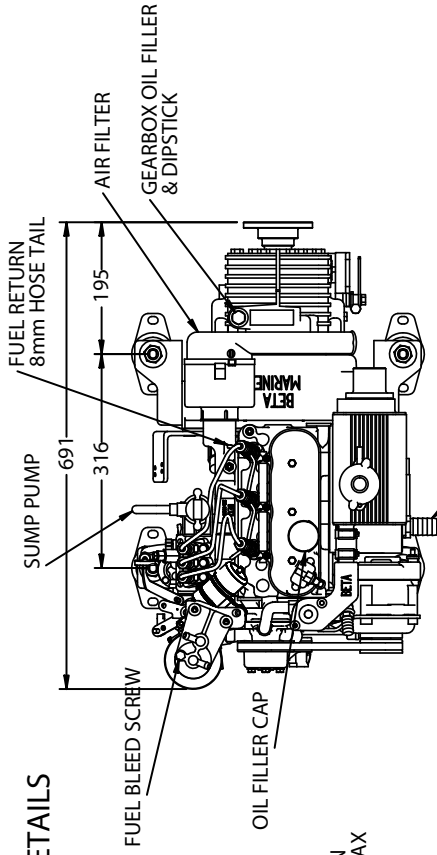
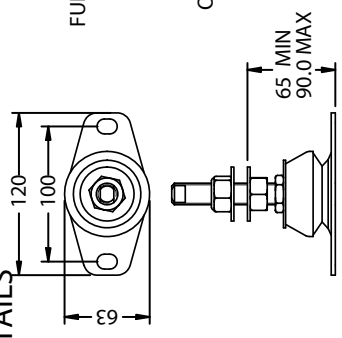
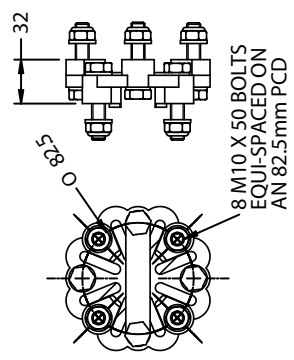

REV	DESCRIPTION	DATE	APP'D	DRAWN	NOTES
01	ADDED NOTES	08-12-03	DM	TW	
02	FUEL FILTER, TANK AND AIR FILTER	25/10/03	LT	TW	
03	CALORIFIERS AND TIER2 CLOSED BREATH	17/2/05		TW	

TITLE  
**BETA 20 KEEL COOLED  
PRM80 GEARBOX**

---

DRAWN BY: **TW**      SIZE: **A4**      DWG NO: **100-05749**      REV: **03**

CHECKED BY:      SCALE:      PAGE: **1 of 1**      DATE: **05/10/2007**

---

DIMENSIONS IN MM (INCH)  
DO NOT SCALE

**BETA MARINE**  
BETA MARINE LTD.  
DAVY WAY, WATERWELLS,  
QUEDGELEY, GLOUCESTER  
GL2 2AD UK  
TEL: +44 (0)1452 723492      FAX: +44 (0)1452 883742

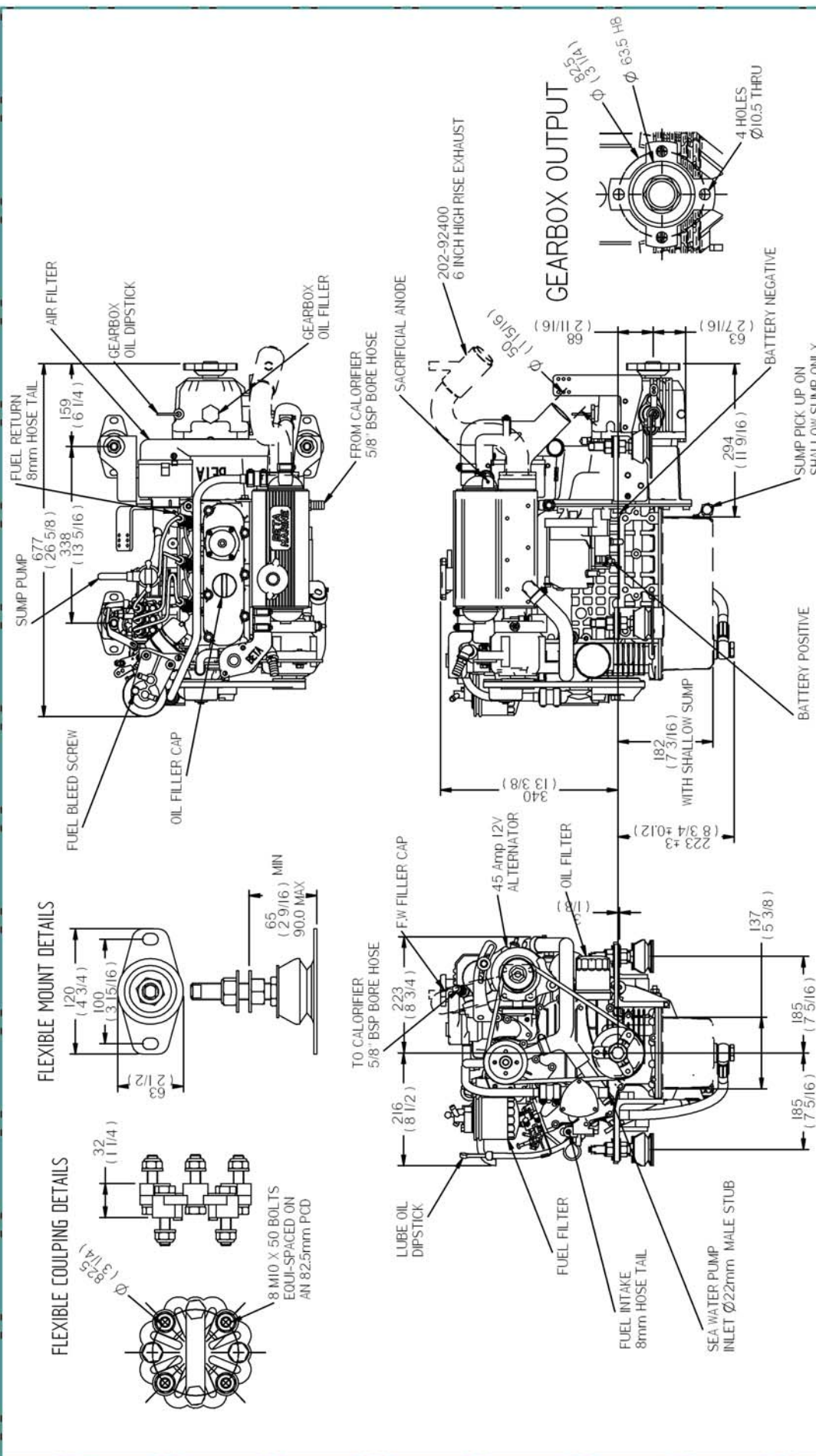

REV	DESCRIPTION	DATE	APPD	DRAWN	NOTES
01	CLORIFIERS AND SHALLOW SUMP	19/10/06		TW	

DIMENSIONS IN MM (INCH) DO NOT SCALE			
BETA MARINE LTD. DAVY WAY, WATERWELLS, QUEDGELEY, GLOUCESTER GL2 2AD UK TEL +44 (0)1452 723492 FAX +44 (0)1452 883742			
DRAWN BY: <b>timw</b> CHECKED BY:	SIZE: <b>A4</b> DWG NO: <b>100-06495</b>	SCALE:	REV: <b>01</b> DATE: <b>12/08/2009</b>

TITLE **BETA 25 (BD902) HEAT EXCHANGE  
TMC40 GEARBOX**

**FLEXIBLE MOUNT DETAILS**

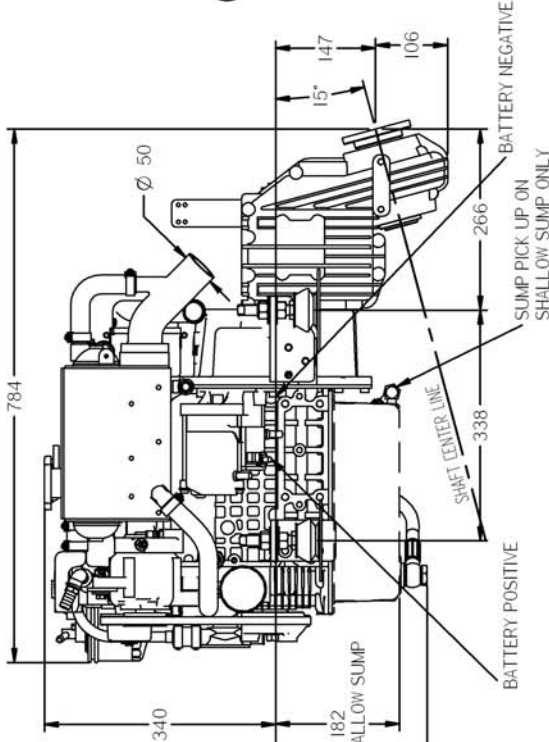
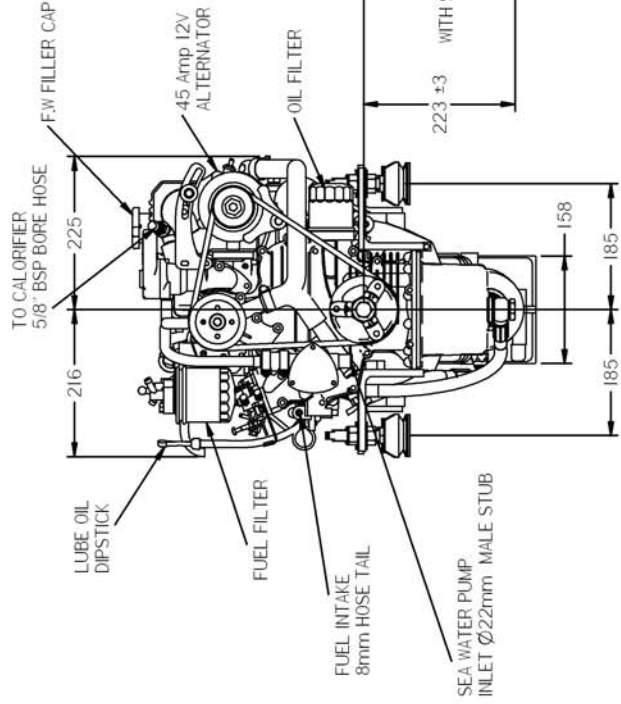
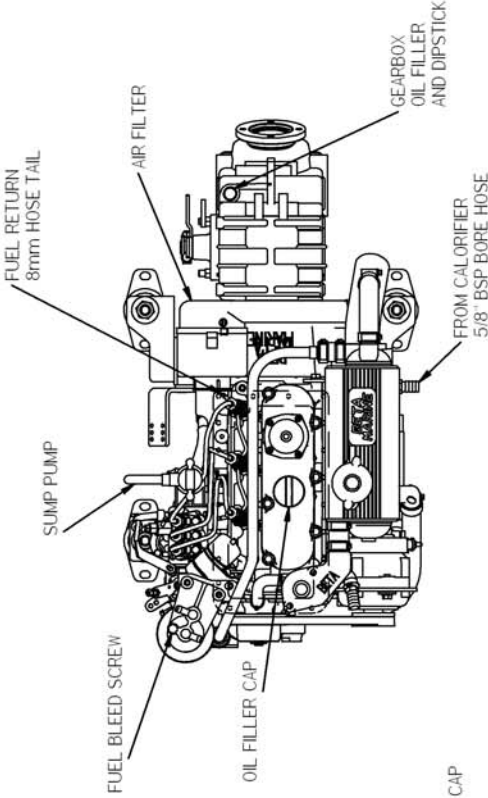
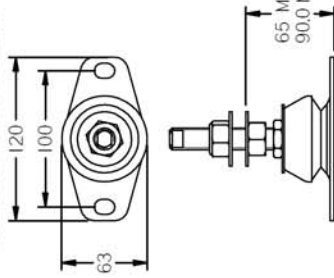

**GEARBOX OUTPUT**

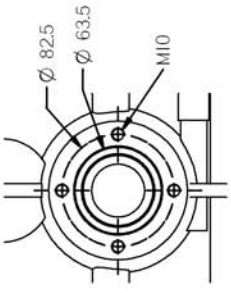

REV	DESCRIPTION	DATE	APPD	DRAWN	NOTES	TITLE
01					NO FLEXIBLE COUPLING SUPPLIED SUGGEST CENTER TYPE 16	<b>BETA 25 HEAT EXCHANGE ZF15MIV GEARBOX</b>
DIMENSIONS IN MM (INCH) DO NOT SCALE						PART FILE NAME: 100-08483_BD902_HE_ZF15MIV_88m BETA MARINE LTD. DAVY WAY, WATERWELLS, CROSBELLY, GLOUCESTER, GL4 2AD, UK TEL: (01452) 723492    FAX: (01452) 729916
DRAWN BY: <b>TW</b>		SIZE: <b>A4</b>	DWG NO: <b>100-08483</b>	REV: <b>00</b>		
CHECKED BY: <b>LT</b>		SCALE: <b>NTS</b>	PAGE: <b>1 of 1</b>	DATE: <b>04/10/2008</b>		

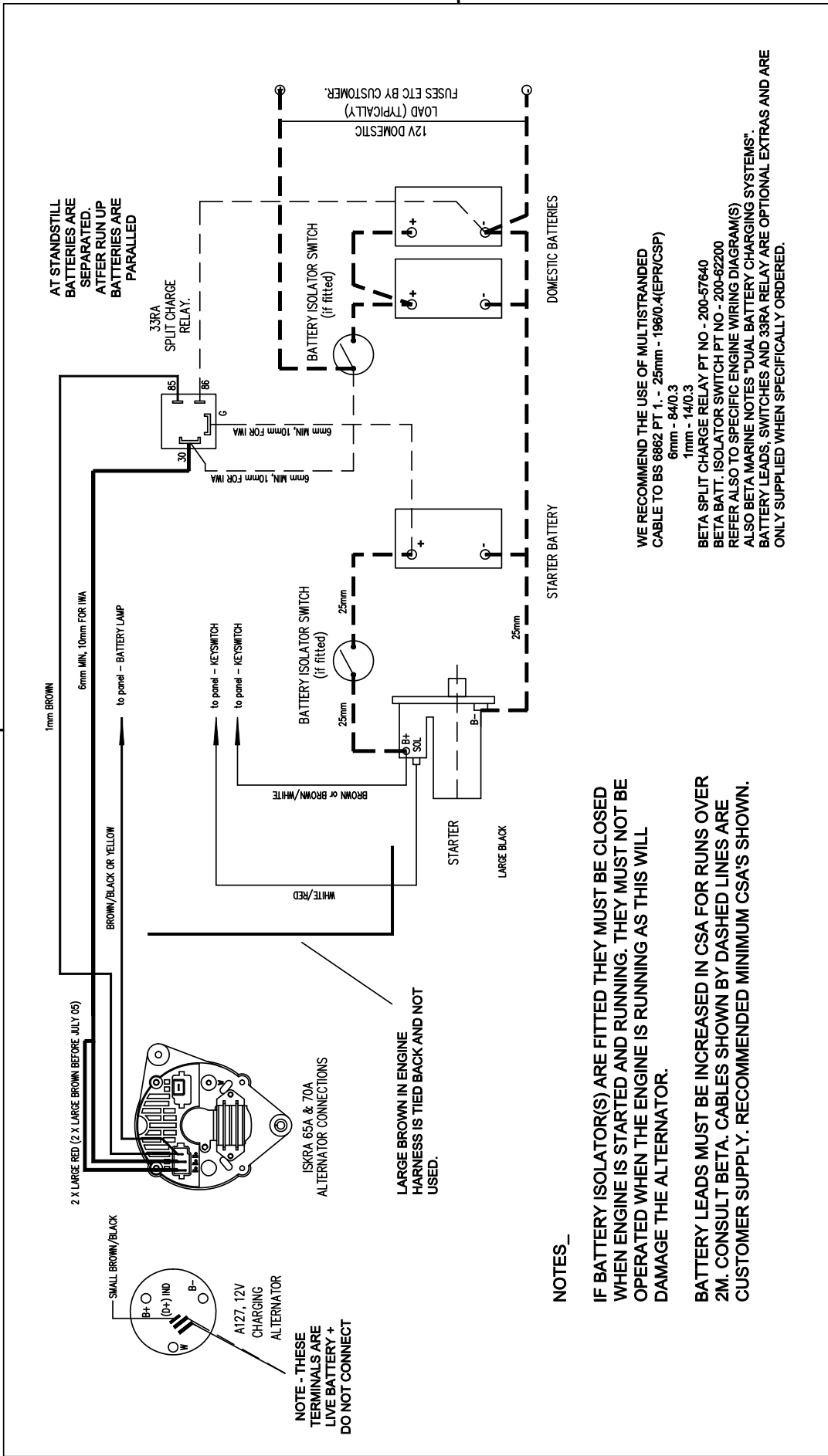

**WE RECOMMEND THE USE OF MULTISTRANDED CABLE TO BS 6862 PT 1, - 25mm<sup>2</sup> - 196/0.4(EPR/CSP) 6mm<sup>2</sup> - 84/0.3 1mm<sup>2</sup> - 14/0.3**

**BETA SPLIT CHARGE RELAY PT NO - 200-57640**  
**BETA BATT. ISOLATOR SWITCH PT NO - 200-62200**  
**REFER ALSO TO SPECIFIC ENGINE WIRING DIAGRAM(S)**  
**ALSO BETA MARINE NOTES "DUAL BATTERY CHARGING SYSTEMS".**  
**BATTERY LEADS, SWITCHES AND 33RA RELAY ARE OPTIONAL EXTRAS AND ARE ONLY SUPPLIED WHEN SPECIFICALLY ORDERED.**

**NOTES\_**

**IF BATTERY ISOLATOR(S) ARE FITTED THEY MUST BE CLOSED WHEN ENGINE IS STARTED AND RUNNING. THEY MUST NOT BE OPERATED WHEN THE ENGINE IS RUNNING AS THIS WILL DAMAGE THE ALTERNATOR.**

**BATTERY LEADS MUST BE INCREASED IN CSA FOR RUNS OVER 2M. CONSULT BETA. CABLES SHOWN BY DASHED LINES ARE CUSTOMER SUPPLY. RECOMMENDED MINIMUM CSA'S SHOWN.**

REV	DESCRIPTION	DATE	APP'D	NOTES	COMPLETE UNIT
01	REDRAWN ON CAD	01.08.2001	TW	<b>FOR BLOCKING DIODE SYSTEM REFER TO DRAWING 300-62220. DRAWINGS 200-02189, 300-00212 SHEETS 1, 2 AND 3 ALSO RELATE TO SPLIT CHARGE AND INSULATED SYSTEMS.</b> <b>(ISSUE 02+ OF THIS DRAWING ALSO REPLACES 300-97720).</b>	TYPICAL INSALLATION FOR SPLIT CHARGE DUAL BATTERY SYSTEM, MACHINE SENSED ALTERNATORS.
02	MINOR MODIFICATIONS AND NOTES	10.10.2001	PAG		TITLE
03	CHANGED STD ALTERNATOR	05.06.2003	DM		SPLIT CHARGE RELAY INSTALLATION.
04	CHANGED NOTES	15.12.2005	DM		DWG NO.
					300-62210
					DATE
					OCTOBER 1997
					SHEET
					1 OF 1



**DRAWN BY:-- PAG**  
**CHECKED BY:--**

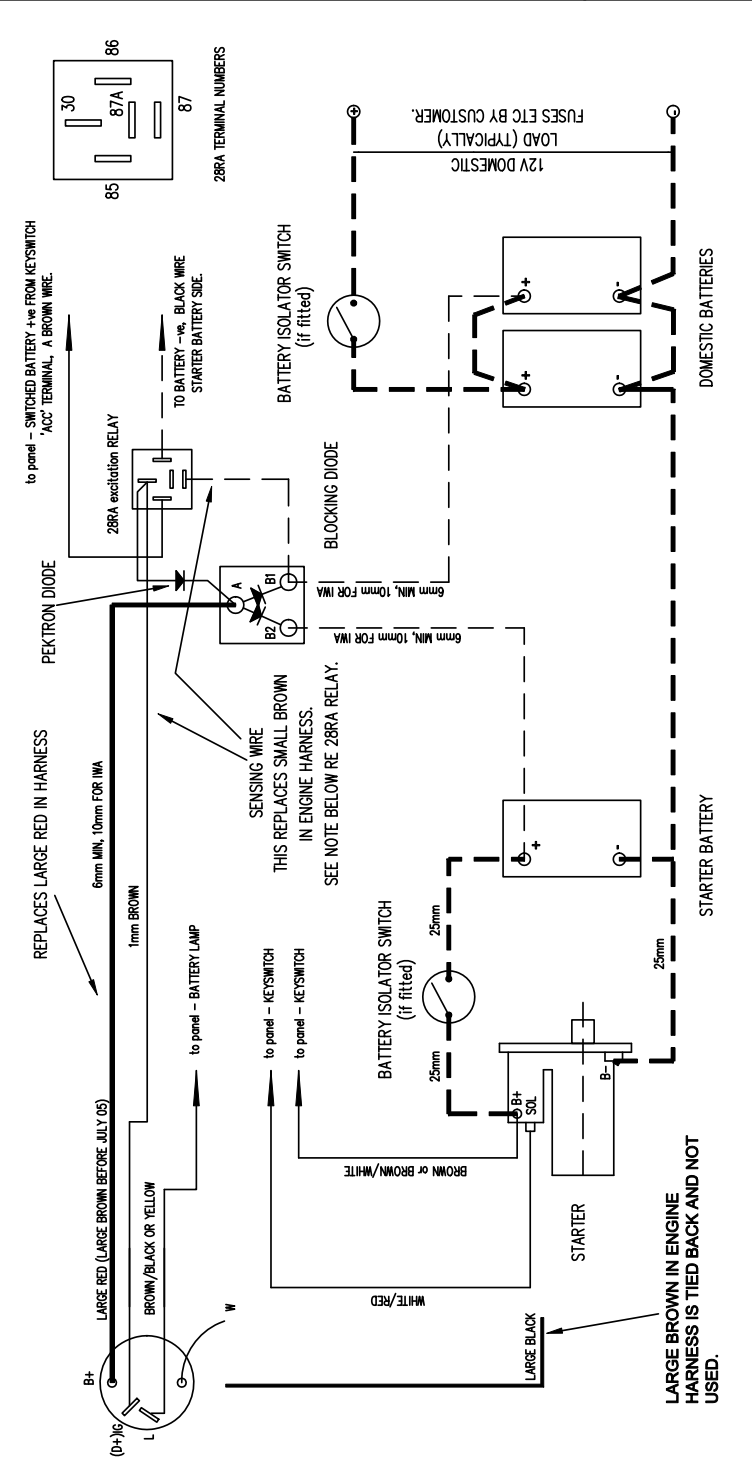
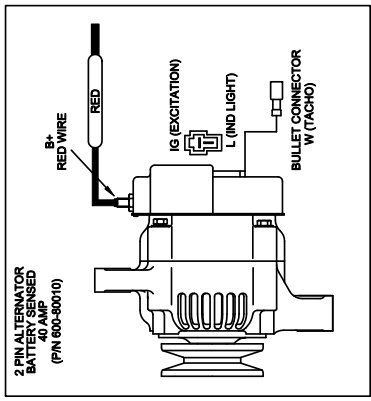
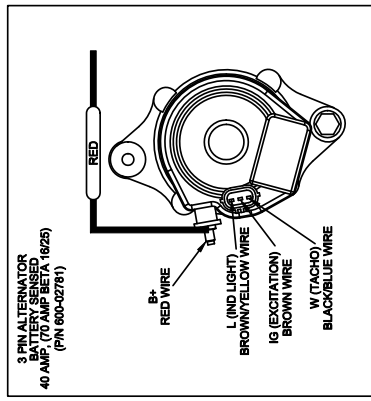

**NOTES**  
IF BATTERY ISOLATOR(S) ARE FITTED, THEY MUST BE CLOSED WHEN ENGINE IS STARTED AND RUNNING. THEY MUST NOT BE OPERATED WHEN THE ENGINE IS RUNNING AS THIS WILL DAMAGE THE ALTERNATOR.  
BATTERY LEADS MUST BE INCREASED IN CSA FOR RUNS OVER 2M. CONSULT BETA. CABLES SHOWN BY DASHED LINES ARE CUSTOMER SUPPLY. RECOMMENDED MINIMUM CSA'S SHOWN.  
BLOCKING DIODE MUST BE SIZED TO COPE WITH THE FULL ALTERNATOR OUTPUT.

WE RECOMMEND THE USE OF MULTISTRANDED CABLE TO BS 6862 PT 1. - 25mm - 1860/4(EPR/CSP) 6mm - 840.3 1mm - 140.3  
BETA SPLIT CHARGE RELAY PT NO. - 200-57640  
BETA BATT. ISOLATOR SWITCH PT NO. - 200-62200  
REFER ALSO TO SPECIFIC ENGINE WIRING DIAGRAM(S)  
ALSO BETA MARINE NOTES "DUAL BATTERY CHARGING SYSTEMS".  
BATTERY LEADS, SWITCHES AND RELAYS ARE OPTIONAL EXTRAS AND ARE ONLY SUPPLIED WHEN SPECIFICALLY ORDERED.

NOTE RE 28RA RELAY. THIS RELAY IS TO BE INSTALLED IF DOMESTIC BATTERIES ARE TO BE SENSED. IT CAN BE OMITTED AND THE ORIGINAL SMALL BROWN RETAINED TO THE PANEL, IN WHICH CASE THE ALTERNATOR WILL SENSE THE STARTER BATTERY.

REV	DESCRIPTION	DATE	APP'D	NOTES	COMPLETE UNIT
02	REDRAWN ON CAD	15.10.2001	PAG	FOR SPLIT CHARGE RELAY SYSTEM REFER TO DRAWING 300-62210. DRAWING 200-02189 MAY ALSO BE OF ASSISTANCE.	TYPICAL INSTALLATION FOR SPLIT CHARGE DUAL BATTERY SYSTEM, BATTERY SENSED ALTERNATORS.
03	SHOWN BATTERY CABLE IN DASHED	15.02.05	TW	(ISSUE 02+ OF THIS DRAWING ALSO REPLACES 300-97720).	TITLE BLOCKING DIODE SPLIT CHARGE INSTALLATION.
04	ADDED MISSING - BATTERY CONNECTION	01.12.05	TW		DWG NO. <b>300-62220</b>
05	CHANGED ALT & SHOWN 3 PIN ALT	15.12.05	TW		DATE <b>OCTOBER 1997</b>
06	TEXT ON LARGE BROWN	21.08.07	TW		REV <b>05</b>
07	BETA 16 AND 25 ALT	10.11.08	TW		SHEET <b>1 OF 1</b>

**BETA MARINE**

DRAWN BY: PAG  
CHECKED BY: -

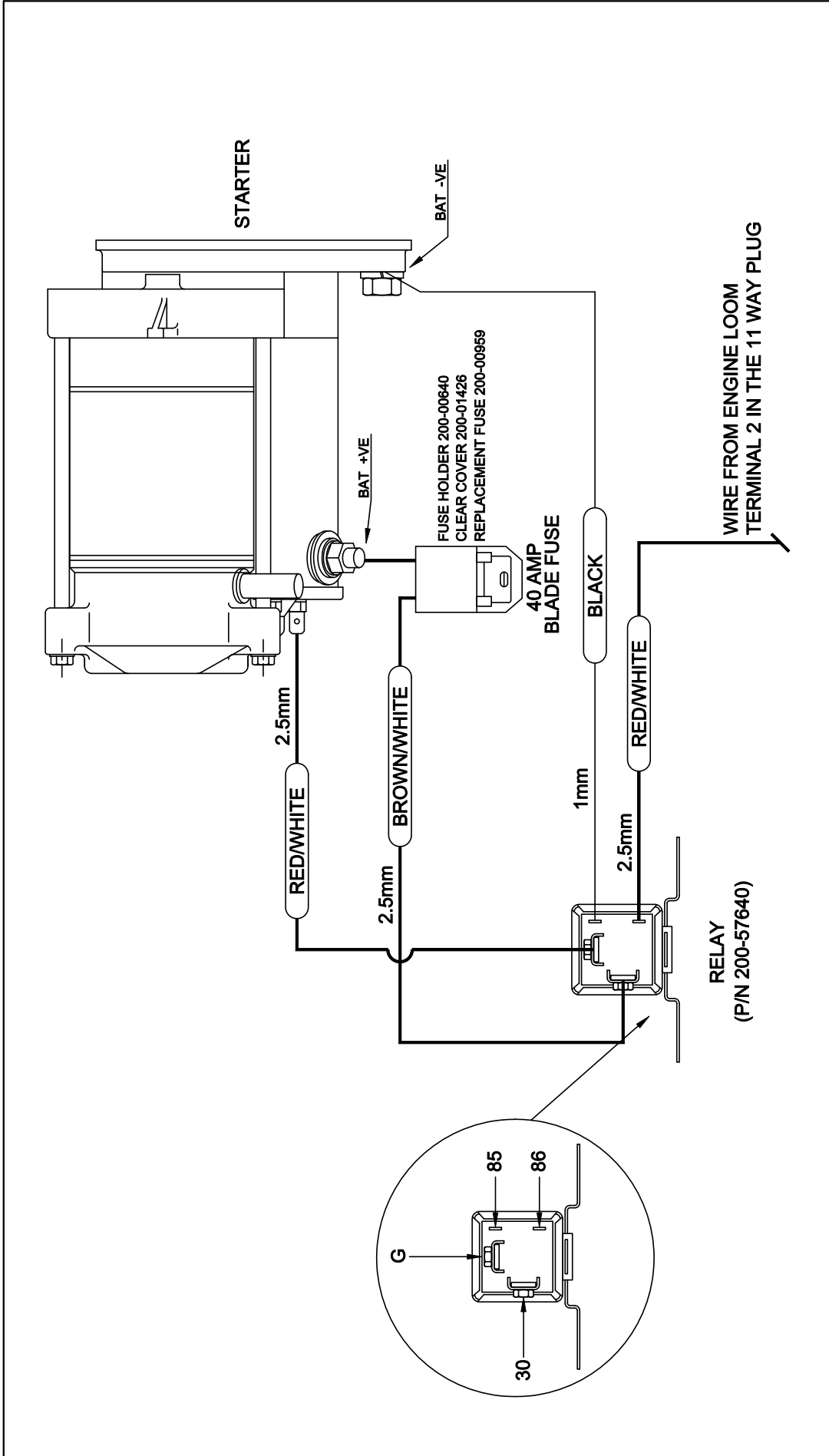

REV	DESCRIPTION	DATE	APP'D	DRAWN	NOTES	TITLE		
01	wiring change	18/01/08	DM	TW		STARTER RELAY FOR EXTENDED HARNESS OVER 4m TOTAL LENGTH		
						DRAWN BY: TW CHECKED BY: DM		
						SIZE	DWG NO.	REV
						A4	300-58520	01
						SCALE	PAGE	DATE
						N/A	1 of 1	16/10/02
						DIMENSIONS IN MM (INCH) DO NOT SCALE  BETA MARINE LTD. DAVY WAY, WATERWELLS, QUEDGELEY, GLOUCESTER GL2 2AD UK TEL +44 (0)1452 723492 FAX +44 (0)1452 883742		





**Declaration of Conformity for Recreational Craft Propulsion Engine with the Exhaust emission requirements of Directive 94/25/EC as amended by 2003/44/EC**

*(Completed by manufacturer of inboard engines without integral exhaust)*

**Name of engine manufacturer:** Beta Marine Limited  
**Street:** Davy Way, Waterwells **Town:** Quedgeley, Gloucestershire  
**Post Code:** GL2 2AD **Country:** U.K.

**Name of Authorised Representative:** not applicable

**Name of Notified Body for exhaust emission assessment:** Germanischer Lloyd  
**Address:** Vorsetzen 35 **Town:** Hamburg **Post Code:** 20459 **Country:** Germany **ID Number:** 0098

**Conformity assessment module used for exhaust emissions:**  B+C

**DESCRIPTION OF ENGINES AND ESSENTIAL REQUIREMENTS**

Engine type: Inboard engine.  
 Fuel type: Diesel gas oil JIS K2204:1997 or equal.  
 Combustion cycle: 4-stroke.

**IDENTIFICATION OF ENGINE(S) COVERED BY THIS DECLARATION OF CONFORMITY**

Name of engine model	Unique Engine family code	EC Type examination certificate number
Beta 10	5KBXL.719KCB	35559-06 HH
Beta 14 BZ482	5KBXL.719KCB	35559-06 HH
Beta 20 BD722	5KBXL.719KCB	35559-06 HH

Essential requirements	Standards	Other normative document method	Technical file	Please specify in more detail (*=mandatory standard)
<b>Annex I.B – Exhaust Emissions</b>				
engine identification	<input checked="" type="checkbox"/>	<input type="checkbox"/>	<input type="checkbox"/>	2033/44 annex 1B para 1.
exhaust emission requirements	<input checked="" type="checkbox"/> *	<input type="checkbox"/>	<input type="checkbox"/>	*EN ISO 8178 – 1 : 1996
durability	<input checked="" type="checkbox"/>	<input type="checkbox"/>	<input type="checkbox"/>	2033/44 annex 1B para 3.
owner's manual	<input checked="" type="checkbox"/>	<input type="checkbox"/>	<input type="checkbox"/>	2033/44 annex 1B para 4.
<b>Annex I.C – Noise Emissions</b>	see Declaration of Conformity of the craft in which the engine(s) has (have) been installed			

This declaration of conformity is issued under the sole responsibility of the manufacturer. I declare on behalf of the engine manufacturer that the engine(s) is (are) in conformity with the type(s) for which above mentioned EC type-examination or type approval certificate(s) has(have) been issued and will meet the exhaust emission requirements of Directive 94/25/EC as amended by Directive 2003/44/EC when installed in a recreational craft, in accordance with the engine manufacturer's supplied instructions and that this (these) engine(s) must not be put into service until the recreational craft into which it is (they are) to be installed has been declared in conformity with the relevant provisions of the above mentioned Directives.

Name J. A. Growcoot **Signature and title:**  
 (identification of the person empowered to sign on behalf of the engine manufacturer)

 C.E.O.

Date: (yr/month/day) 2008 / 11 /04 Quedgeley, Gloucestershire  
 Certificate 3GL Revision 02, engine references updated.

**Declaration of Conformity for Recreational Craft Propulsion Engine with the Exhaust emission requirements of Directive 94/25/EC as amended by 2003/44/EC**

*(Completed by manufacturer of inboard engines without integral exhaust)*

**Name of engine manufacturer:** Beta Marine Limited

**Street:** Davy Way, Waterwells

**Town:** Quedgeley, Gloucestershire

**Post Code:** GL2 2AD

**Country:** U.K.

**Engine type-approved according to:** Stage II of Directive 97/68/EC

(Name of Notified Body for exhaust emission assessment: TUV Kraftfahrt GmbH, Flensburg, Germany accreditation number DAR KBA-P 00010-96)

**DESCRIPTION OF ENGINES AND ESSENTIAL REQUIREMENTS**

Engine type: Inboard engine.

Fuel type: Diesel gas oil JIS K2204:1997 or equal.

Combustion cycle: 4-stroke.

ENGINE(S) COVERED BY THIS DECLARATION	
Engine models and engine family names:	EC Type certificate number (exhaust)
BD1703 Beta 39 BV1903 Beta 43 BV2003 Beta 43 BV2203 Beta 50 YKBXL02.2FCD	e1*97/68DA*2001/63*0072*05 e1*97/68DA*2004/26KA*0072*08 e1*97/68DA*2004/26KA*0072*09
BV2203 6KBXL02.2FCC	e1*97/68KA*2004/26*0375*00
BV2403 Beta 60 3KBXL02.4HCD	e1*97/68GA*2001/63*0147*01
BV3300 Beta 75 3KBXL03.3BCD	e1*97/68GA*2001/63*0145*00
BV3600 Beta 75 7KBXL03.6BCD	e1*97/68JA*2004/26*0430*00
BV3300T 3KBXL03.3BAD	e1*97/68GA*2001/63*0144*00
BV3800 Beta 90 3KBXL03.8ACD	e1*97/68GA*2001/63*0155*00
BV3800T Beta 105 7KBXL03.8AAD	e1*97/68JA*2004/26*0418*00

ENGINE(S) COVERED BY THIS DECLARATION	
Engine models and engine family names:	EC Type certificate number (exhaust)
BZ602 Beta 16 BD902 Beta 25 3KBXL898KCD 7KBXL898KCB	e1*97/68DA*2002/88*0266*00
BD905 BD1005 Beta 28 BV1305 Beta 35 3KBXL01.3BCD	e1*97/68DA*2001/63*0157*00 e1*97/68DA*2004/26KA*0157*02
BD1105 Beta 30 BV1505 Beta 35/38 3KBXL01.5BCD	e1*97/68DA*2001/63*0160*00 e1*97/68DA*2004/26KA*0164*02

Essential requirements	Standards Used	Other normative document used	See technical file
<b>Annex I.B – Exhaust Emissions</b>			
engine identification	N/A	2033/44 annex 1B para 1.	QA025
exhaust emission requirements	N/A	2003/44 para 16, L214/19	EC type certificate has its own technical file.
durability	N/A	2033/44 annex 1B para 3.	QA033
owner's manual	BS EN ISO 10240	2033/44 annex 1B para 4.	N/A
<b>Annex I.C – Noise Emissions</b>		see craft manufacturer's Declaration of Conformity	

I declare on behalf of the engine manufacturer that the engine(s) will meet the exhaust emission requirements of Directive 94/25/EC as amended by Directive 2003/44/EC when installed in a recreational craft, in accordance with the engine manufacturer's supplied instructions and that this (these) engine(s) must not be put into service until the recreational craft into which it is (they are) to be installed has been declared in conformity with the relevant provisions of the above mentioned Directive

Name J. A. Growcoot  
(identification of the person empowered to sign on behalf of the engine manufacturer)

Signature and title:

 C.E.O.

Date: (yr/month/day) 2008 / 10 / 22 Quedgeley, Gloucestershire  
Certificate 2.07 Revision 07, name of notified body added.

# Emission Durability

## ***In respect to the Recreational Craft Directive 94/25/EC and amendment 2003/44/EC Annex 1, B3.***

*The engine must be installed, maintained and operated within the parameters detailed in the Operator's Maintenance Manual. Maintenance must use approved materials, parts and consumables. Should the engine lie unused for a period in excess of 6 months it must be inhibited otherwise it will deteriorate with resulting decrease in performance. See also the Winterising and Laying Up procedures in the Operator's Maintenance Manual.*

*The fuel settings of the diesel injection system must not be tampered with otherwise the guarantee will be invalid and the performance may fall outside prescribed limit. Such adjustment cannot be allowed under the terms of the emission certification.*

*Performance of the engine depends upon the use of correct fuels, lubricants and inhibitors. These are fully detailed in the Operator's Maintenance Manual.*

*Particular attention must be paid to the installation with respect to the exhaust system. The system must be designed so that water cannot back feed into the engine. The run must be such that the back pressure at the engine manifold does not exceed the level detailed in the Operator's Maintenance Manual. Wet, water injected, exhaust systems must be at least the bore mentioned in the Operator's Maintenance Manual and should the run be excessive this bore must be increased accordingly. Back pressure is measured at the outlet of the engine manifold before the water injection bend or dry bellows.*

*Our experience since 1987 has shown that properly installed and maintained engines hold their performance without major mishap even when running hours exceed those mentioned in the Recreational Craft Directive. It is the owners / users responsibility to ensure that the engine continues to function properly and any malfunction must be immediately investigated. The Trouble Shooting section as detailed in the Operator's Maintenance Manual is particularly helpful in this respect. Engine performance, especially with respect to erratic running, exhaust condition, low power output and high oil consumption are indications of engine conditions that may result in emissions outside the prescribed limits and must therefore be investigated and rectified immediately.*

## Fast Moving Parts Listings

H/E & K/C: **Beta 10, 14, 16, 20 & 25.** In all cases please quote **Beta Marine WOC “K” number** and Engine type.

Description	Part Number	Qty per Engine
5” High Rise 50mm <b>Water Injection Exhaust Bend</b>	202-92400/22	1
Exhaust Bend <b>Gasket</b>	600-62620	1
<b>Drive Plate</b> 22-B-60 - PRM/ZF	206-91950	1
<b>Drive Plate</b> 22-B-60 - TMC/ZF	206-97041	1
<b>Flexible Mountings</b> (Trelleborg RA60)	213-93440	4
<b>Rocker Cover Gasket</b> - Beta 10 / Beta 14	600-01055	1
<b>Rocker Cover Gasket</b> - Beta 16	600-05467	1
<b>Rocker Cover Gasket</b> - Beta 20	600-00607	1
<b>Rocker Cover Gasket</b> - Beta 25	600-05468	1
<b>Head Gasket</b> - Beta 10 / Beta 14	600-00409	1
<b>Head Gasket</b> - Beta 16	600-05469	1
<b>Head Gasket</b> - Beta 20	600-01562	1
<b>Head Gasket</b> - Beta 25	600-05470	1
<b>Top Gasket Set</b> - Beta 10 / Beta 14	600-00383	1
<b>Top Gasket Set</b> - Beta 16	600-05471	1
<b>Top Gasket Set</b> - Beta 20	600-00395	1
<b>Top Gasket Set</b> - Beta 25	600-05472	1
<b>Lower Gasket Set</b> - Beta 10 / Beta 14	600-01056	1
<b>Lower Gasket Set</b> - Beta 16	600-05473	1
<b>Lower Gasket Set</b> - Beta 20	600-00394	1
<b>Lower Gasket Set</b> - Beta 25	600-05474	1
<b>Manuals</b>		
<b>Operators Maintenance Manual</b>	221-02887	1
<b>Workshop Manual</b> – Beta 10, Beta 14 & Beta 20	600-00756	1
<b>Workshop Manual</b> – Beta 16 & Beta 25	600-06242	1
<b>Spare Parts Manual</b> – Beta 10 & Beta 14	600-02437	1
<b>Spare Parts Manual</b> – Beta 16	600-05476	1
<b>Spare Parts Manual</b> – Beta 20	600-02438	1
<b>Spare Parts Manual</b> – Beta 16	600-05477	1

**Note:** the above part numbers are suitable for earth return installations only (where battery negative cable is connected directly to engine ground).

For insulated earth (where battery negative cable is isolated from engine ground) different harnesses, alternators, switches for oil pressure and engine temperature will be required.

## Fast Moving Parts Listings

H/E & K/C: **Beta 10, 14, 16, 20 & 25.** In all cases please quote **Beta Marine WOC "K" number** and Engine type.

Description	Part Number	Qty per Engine
Panel <b>'A' Standard</b>	AK/2AS/KS01	1
Panel <b>'ABV'</b> with tachometer	AK/2ABV/KS01	1
Panel <b>'ABVW'</b> with tachometer	AK/2ABVW/KS01	1
Panel <b>'B'</b> with tachometer and gauge	AK/2BT/KS01	1
Panel <b>'C' Deluxe</b> with tachometer and three gauges	AK/2CD/KS01	1
Control Panel standard <b>Key</b> - (to June 2008)	600-00058	a pair
Control Panel standard <b>Key</b> - (from June 2008)	600-00058/01	a pair
Control Panel <b>Key Switch</b> - (to June 2008)	600-00057	a pair
Control Panel <b>Key Switch</b> - (from June 2008)	600-00057/01	a pair
Control Panel <b>Stop Button</b> (and heat & start on ABVW)	200-00072	1
<b>Tachometer</b> 0-4000 rpm with digital hour counter	200-02373	1
<b>Water temperature</b> switch <b>Gauge</b> (B & C panels)	200-96200	1
<b>Oil pressure</b> switch <b>Gauge</b> (C panels only)	200-96190	1
<b>Voltmeter</b> (C panels only)	200-96210	1
Green power on <b>indicator lamp</b> & retaining clip	200-04656	1
Red warning <b>indicator lamp</b> & retaining clip	200-04657	3 of 4
<b>Alarm boards</b>	200-04655	1
<b>Relay 12 Volt</b> 40A (28Ra) fitted to rear of panels	200-87020	1
<b>Stop Solenoid</b> (energised to stop fuel)	600-81950	1
<b>Fuse</b> (Blade) 40 Amp	200-00959	1
Standard <b>Engine Harness</b>	200-98380/01	1
65 Amp Alternator <b>Sub Loom</b> (External Fan)	200-01196	1
1 Metre control panel extension loom	200-04588/01	
2 Metre control panel extension loom	200-04588/02	
3 Metre control panel extension loom	200-04588/03	
4 Metre control panel extension loom	200-04588/04	
<b>Water Temperature Switch</b> (Panel A, ABV & ABVW NOT Beta 16 or Beta 25, (ONLY Beta 10, 14 or 20 up to March 2007)	200-01133	1
<b>Water Temperature Switch</b> - with single terminal Beta 16 & Beta 25 (standard from March 2007 for Panel A, ABV & ABVW)	600-62820	1
<b>Water Temperature Sender</b> 5/8UNF (Panel C & B)	200-94360	1
<b>Water Temperature Sender</b> 1/8UNF (Panel C & B)	200-08248	1
<b>Oil Pressure Switch</b> (Panel A, ABV, ABVW & B)	600-62670	1
<b>Oil Pressure Sender</b> (Panel C)	200-94350	1
Standard 50mm <b>Water Injection Exhaust Bend</b>	202-02458	1

## Fast Moving Parts Listings

H/E & K/C: **Beta 10, 14, 16, 20 & 25**. In all cases please quote **Beta Marine WOC "K" number** and Engine type.

Description	Part Number	Qty per Engine
Wasting <b>Zinc Anode</b>	209-61840	1
Heat Exchanger " <b>O</b> " <b>Ring</b> (with single bolt endcap)	209-80110	2
Heat Exchanger " <b>O</b> " <b>Ring</b> (with 3 bolt endcap)	212-07273	2
<b>Pressure Cap</b> 95kPa	209-80130	1
<b>Thermostat</b> (Beta 10, Beta 14 & Beta 20 only)	600-59290	1
<b>Thermostat</b> (Beta 16 & Beta 25 only)	600-72450	1
Thermostat <b>Gasket</b> (Beta 10, Beta 14 & Beta 20 only)	600-62590	1
Thermostat <b>Gasket</b> (Beta 16 & Beta 25 only)	600-80490	1
<b>Fuel Filter</b>	211-60210	1
Air Filter <b>Element</b> (3 clamp steel filter - up to March 2011)	211-62950	1
Air Filter <b>Element</b> (screw-on plastic filter - from March 2011)	211-08132	1
Lubricating <b>Oil Filter</b>	211-63760	1
<b>Sump Pump</b>	210-80061	1
Sump Pump <b>Clamp</b>	212-00793	2
<b>Dip Stick</b> (only) - Extended	600-96280	1
<b>Sea Water Pump</b> (6 Screw)	207-61500/01	1
Sea Water Pump <b>Impeller Kit</b> (includes gasket and screws)	207-05355	1
Sea Water Pump <b>Cover Plate</b>	207-05478	1
Sea Water Pump <b>Cover Plate Bolt</b>	207-05479	6
<b>Fuel Lift Pump</b> (Beta 10, Beta 14 & Beta 20 only)	600-65470	1
<b>Fuel Lift Pump</b> (Beta 16 & Beta 25 only)	AK/MINI/9&6/F0I	1
Fuel Lift Pump <b>Gasket</b>	600-00065	1
<b>Belt</b> – Standard "PolyVee" – (Standard H/E spec from January 2011)	212-05074	Correctly Select a Belt
<b>Belt</b> – Standard "Vee" – 40 Amp (H/E spec from Jan 2011)	214-00126	Correctly Select a Belt
<b>Belt</b> – Standard "Vee" – 40 Amp – (up to Dec 2010)	600-63080	Correctly Select a Belt
<b>Belt</b> – PolyVee 40 Amp 4PK900 (up to Dec 2010 and NOT Beta 25)	214-04360	Correctly Select a Belt
<b>Belt</b> – PolyVee 40 Amp 4PK913 (up to Dec 2010 and ONLY Beta 25)	212-05074	Correctly Select a Belt
<b>Belt</b> – 65 Amp Alt Beta14/Beta20 - 4PK950 External fan (up to Dec 2010)	214-03235	Correctly Select a Belt
<b>Belt</b> – 65 Amp Alternator Beta 16 - 4PK900 Internal fan (up to Dec 2010)	214-04360	Correctly Select a Belt
<b>Belt</b> – 65 Amp Alternator Beta 25 4PK913 Internal fan (up to Dec 2010)	212-05074	Correctly Select a Belt
<b>Alternator 40 Amp</b>	600-80010	1
<b>Alternator 70 Amp</b> (H/E spec from 2011 - Internal Fan)	200-07338	1
<b>Alternator 55 Amp</b> (A127)	200-69190	1
<b>Alternator 65 Amp</b> External Fan	200-01155	1
<b>Alternator 65 Amp</b> Internal Fan	600-04989	1

# Service Record

	<b>Service</b>	<b>Date</b>	<b>Responsible</b>	
1	Commissioned			
2	First 25 hours			
3	First 50 hours			
4	Every 150 hours with shallow sump			
5	Every Year / Every 250 hours if sooner			
6				
7				
8				
9	Every 750 hours			
10				
11				
12				
13				
14				
15				
16				

Heat Exchanger Cooled  
10 to 150bhp

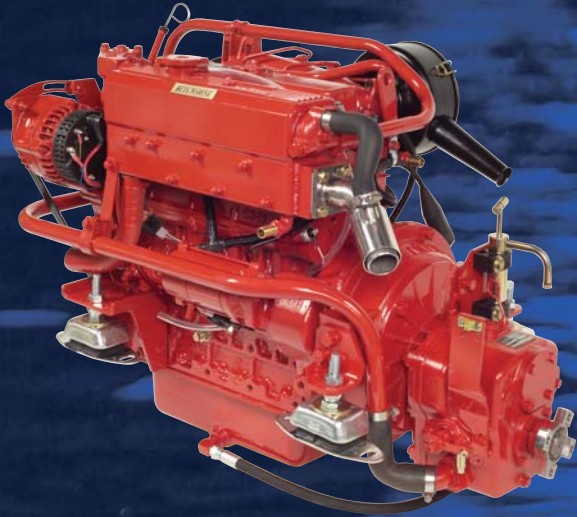

Keel Cooled  
10 to 150bhp

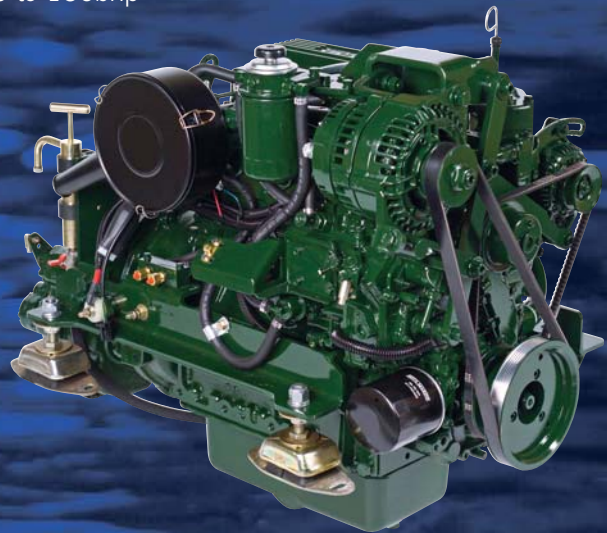

Marine Generating Sets  
4 to 40kVA



Sail Drives  
13.5 to 56bhp



**BETA MARINE**

Beta Marine Limited  
Davy Way, Waterwells  
Quedgeley, Gloucester  
GL2 2AD, UK.

Tel: 01452 723492  
Fax: 01452 883742  
Email: [sales@betamarine.co.uk](mailto:sales@betamarine.co.uk)  
[www.betamarine.co.uk](http://www.betamarine.co.uk)

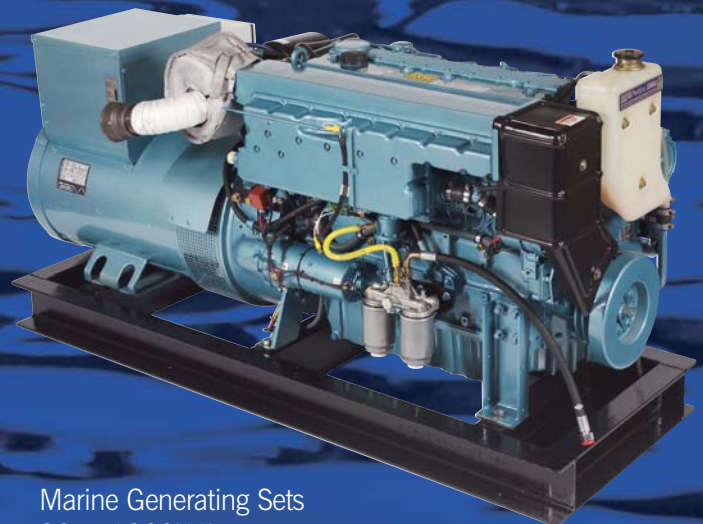

Marine Generating Sets  
30 to 1000kVA

Ref: 1590, May 2011.