BETA MARINE

Operator's Maintenance Manual



Heat Exchanger & Keel Cooled Mid Diesel Engine Range Beta 75 & Beta 90

CALIFORNIA – Proposition 65 Warning: Diesel engine exhaust and some of its constituents are known to the state of California to cause cancer, birth defects and other reproductive harm.

Engine Details

IMPORTANT - Please fill in details at moment of purchase - it really will help you! (and it will really help us specify the correct spare parts for you).

Engine Type:	Power:	bhp	Speed:	rpm
BETA WOC NO:	K			
Gearbox Type:				
Purchased From:				
Invoice No.:				
Date Commissioned:				
Specification / Special Details:				



Contents

My engine details (to be completed now)	Inside front cover
Introduction	
Engine identification	2
Initial receipt of the engine	2
Engine storage	2
Safety precautions	3
Technical specifications	4
Section 1: Installation guidelines	
Engine mounting	5
Engine alignment - drives, flanges, flexible couplings	6
Exhausts and mounting exhausts	7 & 8
Fuel supply and "leak off"	9
Cooling - sea water inlet system	10
Cooling - keel cooling system	10 & 11
Calorifier connections (if fitted)	12
Electrical Installation	13
Section 2: Guidelines for operation of the engine	
Important checks prior to initial use	14
Initial start-up and bleeding the fuel system	14
Starting and stopping	15 & 16
Section 3: Maintenance & Service guidelines	
Maintenance schedule	17 & 18
Lubrication - checking and changing oil	19 & 20
Fuel system - fuel/water separator, fuel lift pump, fuel filter	21
Cooling - fresh water system, heat exchanger	22
Sea water pump, heat exchanger	23
Belt tensioning adjustment	24
Air filter inspection / replacement	25
Electrical maintenance	25
Laying up - winterising	26
Troubleshooting	27
Torque settings	38
Wiring diagrams and general arrangement drawings index	39
Exhaust Emission - Declaration of Conformity	71 & 72
Exhaust Emission - Durability	73
Fast Moving Parts Listing	76, 75 & 74
Maintenance record	Inside back cover

OPERATION AND MAINTENANCE MANUAL FOR THE FOLLOWING BETA MARINE ENGINES BASED ON KUBOTA

Beta 75 & Beta 90

This manual has been compiled to provide the user with important information and recommendations to ensure trouble free and economical operation of the engine.

As manufacturers we have obviously written this "Operators Maintenance Manual" from our 'involved technical viewpoint' assuming a certain amount of understanding of marine engineering. We wish to help you, so if you do not fully understand any phrase or terminology or require any explanations please contact Beta Marine Limited or its distributors and we will be pleased to provide further advice or technical assistance.

All information and recommendations given in this publication are based on the latest information available at the time of publication, and are subject to alteration at any time.

The information given is subject to the company's current conditions of Tender and Sale, is for the assistance of users, and is based upon results obtained from tests carried out at the place of manufacture and in vessels used for development purposes. We do not guarantee the same results will be obtained elsewhere under different conditions.



Engine Identification

NOTE: In all communications with the distributor or Beta Marine, **the W.O.C. and engine number must be quoted.**

Beta 75 and Beta 90

The engine serial number is stamped above starter motor on the port side of the engine, and is shown on the rocker cover label.

Initial Receipt of the Engine

A full inspection of the engine must be made **immediately on delivery** to confirm that there is no damage. If there is any damage then write this clearly on the delivery note and inform your dealer or Beta Marine within 24 hours. A photograph would always help.

Engine Storage

The engine must be stored in a dry, frost free area and this is best done in its packing case. If storage is to be more than six months then the engine must be inhibited (contact your dealer or Beta Marine). Failure to inhibit the engine may result in the formation of rust in the injection system and the engine bores, this could invalidate the warranty.

② **BETA MARINE LTD**

WOC..... K12345

Engine Type... Beta 75

Engine No..... 1Z1234

Output..... 75 BHP @ 3620 RPM

Tel: UK (44) 01452 723492 Fax: UK (44) 01452 883742

Email: sales@betamarine.co.uk

(Quote WOC number for spares)

Safety Precautions!

A Keep the engine, gearbox and surrounding area clean, including the area immediately below the engine

B Drives - Power Take Off Areas

i) Gearbox Output Flange 

The purpose of a marine diesel propulsion engine is to provide motive power to propel a vessel. Accordingly the gearbox output shaft rotates at between 280 and 2400 rev/min. This flange is designed to be coupled to a propeller shaft by the installer and steps must be taken to ensure adequate guarding.

ii) Forward End Drive 

Engines are supplied with unguarded belt drives to power the fresh water pump and battery charging alternator. The installer must ensure that it is not possible for injury to occur by allowing access to this area of the engine. The three pulleys run at high speed and can cause injury if personnel or clothing come in contact with the belts or pulleys, when the engine is running.

iii) Power Take Off Shaft  (Engine Mounted Option)

Shaft extensions are available as an option and rotate at between 850 and 3600 rev/min. If contact is made with this shaft when the engine is running, injury can occur.

C Exhaust Outlet

Diesel marine propulsion engines emit exhaust gases at very high temperatures - around 400 - 500°C. Engines are supplied with either wet exhaust outlet (water injection bend) or dry outlet (dry exhaust stub) - see option list. At the outlet next to the heat exchanger / header tank, the exhaust outlet can become very hot and if touched, can injure. This must be lagged or avoided by ensuring adequate guarding. It is the responsibility of the installer to lag the exhaust system if a dry system is used. Exhaust gases are harmful if ingested, the installer must therefore ensure that exhaust lines are led overboard and that leakage in the vessel does not occur.

D Fuel

i) Fuel Lines 

Diesel engines are equipped with high pressure fuel injection pumps, if leakages occur, or if pipes fracture, fuel at a high pressure can harm personnel. Skin must be thoroughly cleaned in the event of contact with diesel fuel.

ii) Fuel Supply Connections 

Engines are supplied with 8mm compression fittings. The installer must ensure that when connections are made, they are clean and free of leaks.

E Oil

The Beta propulsion unit is supplied with 2 dipsticks, one for the engine and one for the gearbox. Ensure dipsticks are returned and secure after checking, if not oil leaks can cause infection when touched. All oil must be removed from the skin to prevent infection.

F Scalding

An engine running under load will have a closed circuit fresh water temperature of 85° to 95°C. **The pressure cap on the top of the heat exchanger must not be removed when the engine is running.** It can only be removed when the engine is stopped and has cooled down.

G Transportation / Lifting

Engines are supplied on transportable pallets. Lifting eyes on engines are used for lifting engine and gearbox assembly only, not the pallet and associated kit.

GENERAL DECLARATION

This machinery is not intended to be put into service until it has been incorporated into or with other machinery. It is the responsibility of the purchaser / installer / owner, to ensure that the machinery is properly guarded and that all necessary health and safety requirements, in accordance with the laws of the relevant country, are met before it is put into service.

Signed:



J A Growcoot, C.E.O,
Beta Marine Limited

NOTE: Recreational Craft

Where applicable, the purchaser / installer / owner and operator must be responsible for making sure that the Recreational Craft Directive 94/25/EC is complied with.

Technical Specifications

Standard Engines	Beta 75	Beta 90
Cylinder	4	4
Bore (mm)	98	100
Stroke (mm)	120.0	120.0
Displacement (cc)	3620	3769
Combustion	3 Vortex	3 Vortex
Cooling	Water	Water
Starter voltage (V)	12	12
Starter output (kW)	3.0	3.0
H/E Starter alternator output (Amps)	65 (standard)	
K/C Starter alternator output (Amps)	65 (standard) & 175 (Domestic)	
Glow plug resistance (each)	1Ω	N/A
Engine speed (RPM)	2,600	2,600
Power output to ISO3046 (BHP)	75.0	90.0
Declared power ISO8665 (kW)	49.8	60.8
Compression Ratio	22.6:1	20.0:1
Fuel timing BTDC	8°	13°
Capacity of standard sump approx. (litres)	13.2	13.2
Nett dry weight with gearbox (kg)	390	392
Fuel	Diesel fuel oil No.2D	
Coolant	33%-50% maximum antifreeze:water	
Coolant capacity approx. (H/E litres)	10.2	10.2
Coolant capacity approx. (K/C litres)	See boat designer	
Min. recommended battery capacity	12V, 180Ah (1,200 CCA Min)	

Maximum Angle of Installation: Trim 15°; Roll 25° (intermittent) or 20° continuous, see page 6.

Rotation: Anti-clockwise on flywheel, clockwise on output gearbox flange for use with right hand propeller in ahead, on mechanical gearboxes. Hydraulic gearboxes can be left or right handed. Diesel fuel must conform to BS2869-1970 class A1 or A2. The fuel must be a distillate and not a residual oil or blend.

Lubricant:

Engine - engine oil must meet API Classification CF (CD or CE), See section 2 for details

Gearbox - see gearbox operator's manual for the gearbox oil type and capacity

Oil pressure - minimum (tickover) 0.5 bar

Power outputs: These comply with BS EN ISO 8665:1996 crankshaft power

Note: Declared Powers to ISO8665:1996

1. The declared powers are at the same engine speed as the ISO 3046 figures. This speed is the speed related to the outputs / powers shown.
2. Declared powers are at the gearbox coupling (coupling to the propeller shaft) as per clause 3.2.1 with standard specifications as per our current price lists. Additional accessories or alternative gearboxes may affect the declared powers.
3. Operation at parameters outside the test parameters may affect the outputs / powers which in any case are subject to the ISO tolerance bands.

Section 1

Installation Recommendations

The installation details are basic guidelines to assist installation, however due to the great diversity of marine craft it is impossible to give definitive instructions. Therefore Beta Marine can accept no responsibility for any damage or injury incurred during the installation of a Beta Marine Engine whilst following these guidelines.

- All engines shall be placed within an enclosure separated from living quarters and installed so as to minimise the risk of fires or spread of fires as well as hazards from toxic fumes, heat, noise or vibrations in the living quarters.
 - Unless the engine is protected by a cover or its own enclosure, exposed moving or hot parts of the engine that could cause personal injury shall be effectively shielded.
 - Engine parts and accessories that require frequent inspection and / or servicing must be readily accessible.
 - The insulating materials inside engine spaces shall be non-combustible.
 - The engine compartment must be adequately ventilated as the engine will produce radiated heat - approximately equal to $\frac{1}{3}$ of the engine output power. Also the battery charging alternator(s) create lots of heat. Ventilation is normally best with two holes; **an inlet** of at least 200 cm² allowing colder air to enter near to the alternator and drive belts and **a second outlet** (a third bigger than the inlet) for the hot air to rise and ventilate out from the opposite side of the top of the engine compartment.
- In yachts we strongly recommend forced ventilation - using an **extraction fan** to draw out the hot air and limit the engine compartment /room temperature to a maximum of 60°C. You can check the temperature in the engine compartment with a thermometer - the cooler the better - maximum temperature 60°C; this is best done on a hot sunny day. (A symptom of overheating problems is black belt dust).
- Keel cooled engines, overheating is sometimes caused by:
 - a) Not fully venting the engine cooling system of air. It is necessary to remove all air from the cooling system - including the "skin" tanks and (if fitted) the Calorifier and associated piping.
 - b) Incorrectly sized "skin" tanks that have been sized for 'usual' canal use, rather than maximum engine output that can sometimes be required on fast flowing rivers. An additional "skin" tank may need to be fitted; please refer to our website: Inland waterways - guidelines: keel cooling tank sizes.

Engine Mounting

To ensure vibration free operation, the engine must be installed and correctly aligned on substantial beds, extending as far forward and aft as possible, well braced and securely fastened to form an integral part of the hull.

The engine must be installed as low as possible on the flexible mount pillar stud. This will limit vibration and extend the life of the flexible mount. To assist with engine replacement we offer 'Special Engine Feet' manufactured to your dimensions, as an optional extra to suit your existing engine bearers and shaft alignment/installation.

Warning

- (1) Do not set the engine feet high up the flexible mount pillar stud. This will cause excessive engine movement and vibration. Pack under the flexible mount with steel shims securely bolted into the engine bearer.
- (2) The pillar stud on the flexible mount is secured into position by the lower locknut, do not forget to tighten this. **Also ensure that the stud is not screwed too far through the mounting body so that it can touch the bearer. This will cause vibration and knocking noises which are very hard to find!**



Engine Installation at an Angle

Beta Marine propulsion engines can be installed at angles up to a maximum of 15° flywheel up or flywheel down when static, or can be run at up to 25° when heeling. When our engines are installed at varying angles of inclination the normal markings on the dipstick should be disregarded.

It is probably better to totally drain the lubricating oil from the sump, replacing the oil filter with a new one; then add the recommended amount of lubricating oil – noting its position on the dipstick – and then marking the dipstick. If in doubt ask Beta Marine.

Alignment

To obtain accurate alignment the flexible mountings must be adjusted until alignment is attained, and the mountings must be locked in position.

The engine/gearbox unit has to be aligned with the propeller shaft in two ways. The traditional engine alignment method involves measuring with either feeler gauges or a DTI (Dial Test Indicator) mounted on a magnetic foot so that they are aligned within 0.125mm (0.005").

Angular Alignment

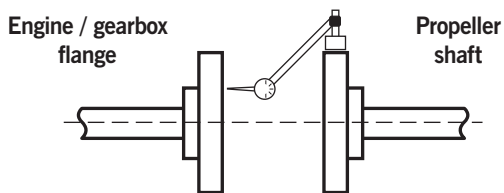

Angular Mis-alignment

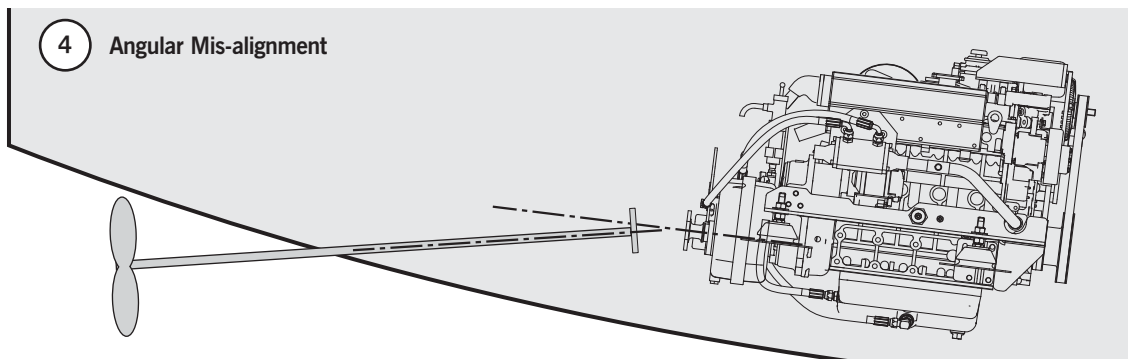
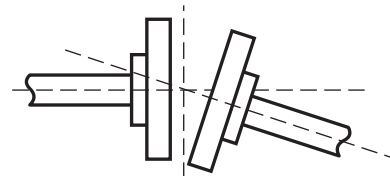

Parallel Alignment

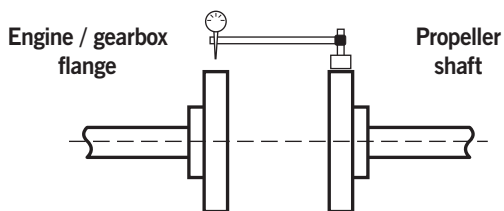

Parallel Mis-alignment

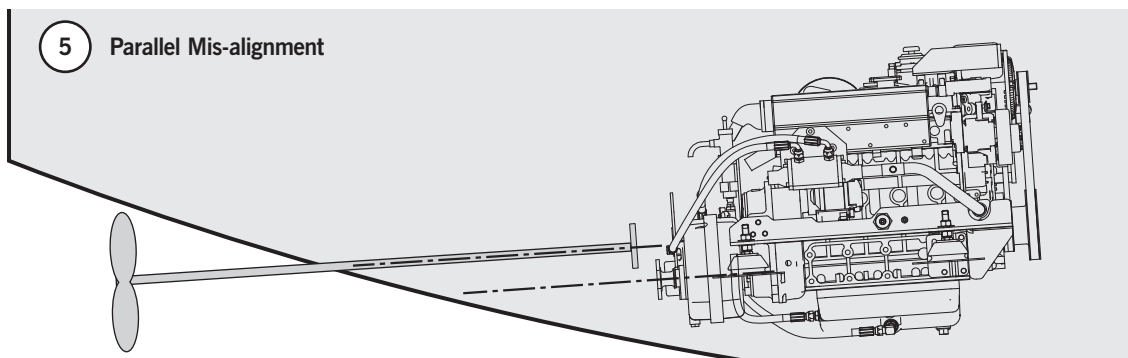
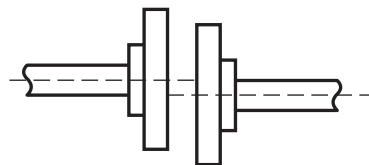

The engine mountings and the couplings must now be tightened in position and the alignment re-checked.

Flexible Output Couplings

A flexible coupling should be mounted on the gearbox output flange and is strongly recommended in almost every case.

Flexible couplings do not accommodate bad alignment, they are designed to absorb torsional vibrations from the propeller (transmitted along the propeller shaft).

Exhausts

- An engine correctly installed in accordance with this handbook will meet the emission requirements of the RCD (see page 64).
- Keep dry exhaust systems to a minimum length and have swept bends (NOT right angle elbows). Exhaust back pressure is increased by longer exhaust length and sharp bends. Back pressure should be measured; with the complete exhaust system connected and the engine running at full speed; and should NOT exceed 60 mm Hg (2.4 inches Hg).

The correct measuring point is before the injection bend (at the manifold flange). Wet Exhaust hose should be matched to the injection bend sizes detailed below.

Exhaust	Beta 75	Beta 90
Standard (High rise)	60 mm	60 mm

Typical Yacht Exhaust Installation

Warning

- One of the most common problems with engine installations (and possibly expensive), is water entering the engine exhaust manifold from the exhaust system by syphoning when the engine is switched off. This can occur when the point of water injection "X" on the engine is close to or below the water line. Water entering the pistons can cause bent con rods, emulsified engine oil and a wrecked fuel pump! It's best avoided!

- This diagram shows a typical exhaust installation. The rubber hose connecting the heat exchanger to the injection bend must be replaced by a hose (a) of sufficient length, connecting to a "T" piece or anti-syphon valve that is above the maximum seawater level when heeled (at least 30 cms / 12 inches above the water line) on the centre line of the boat. The pipe then returns to the injection bend and the seawater is pumped down the exhaust pipe.
- The exhaust back pressure measured at 'x' should NOT exceed 60 mm Hg (2.4 inches Hg).

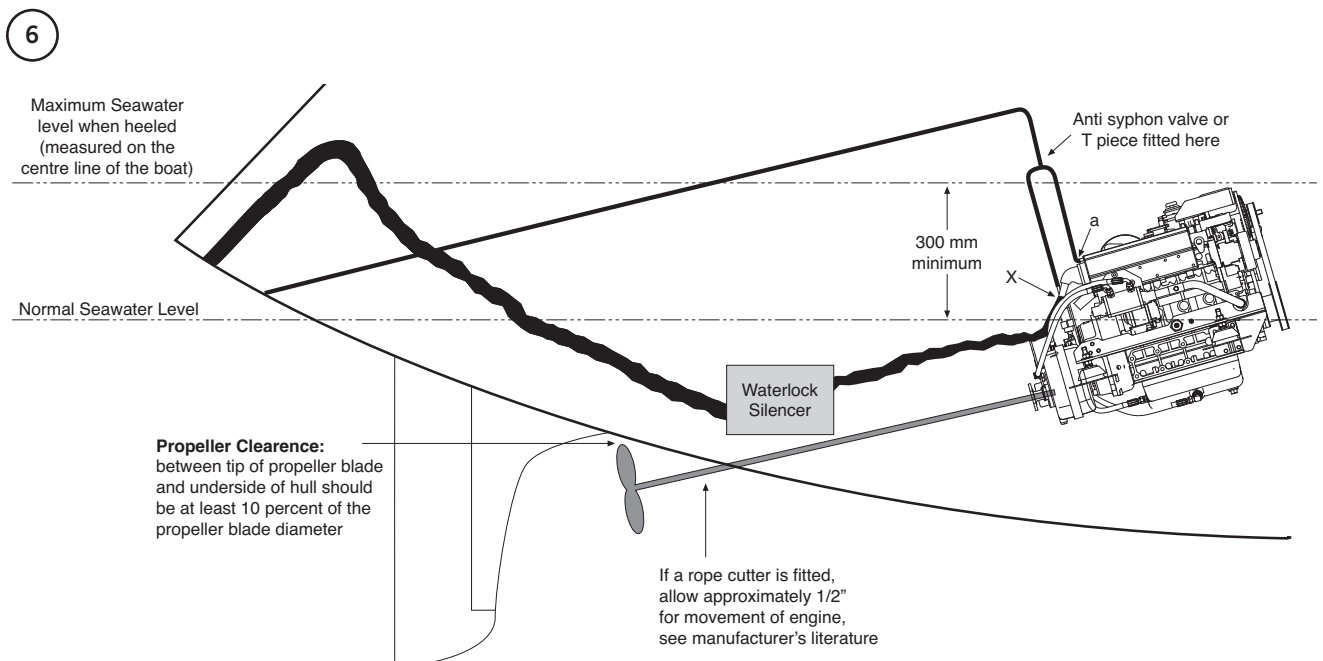

Dry Exhaust System

- An engine correctly installed in accordance with this handbook will meet the emission requirements of the RCD (see pages 59 and 60).
- Keep exhaust systems to a minimum length and have gradual bends (NOT right angle elbows). Exhaust back pressure is increased by longer exhaust length and sharp bends. Back pressure should be measured; with the complete exhaust system connected and the engine running at full speed; and should NOT exceed 60mm Hg (2.4 inches Hg). The correct measuring point is before the dry exhaust bellows (at the manifold flange). We can supply a Manometer kit for testing 'Back Pressure'.
- The dry exhaust system installed in a canal boat or work boat should be 1½" minimum internal diameter.

The engine is fitted with a 1½" BSP male connector stub as standard - Valid for exhaust systems up to 3 metres in length. A flexible exhaust bellows and dry exhaust silencer should be used. It is up to the installer to work out his own pipe run but care should be taken as follows:

- Never use a flexible exhaust bellow as a bend, it will crack, always keep them straight.
- Ensure that rain water cannot enter the exhaust port and run back down the system, flooding the silencer and eventually the engine. (See drawings below).
- The system should be lagged if there is any danger of the crew getting near it.
- A dry exhaust system will give off considerable heat and suitable ventilation must be provided.

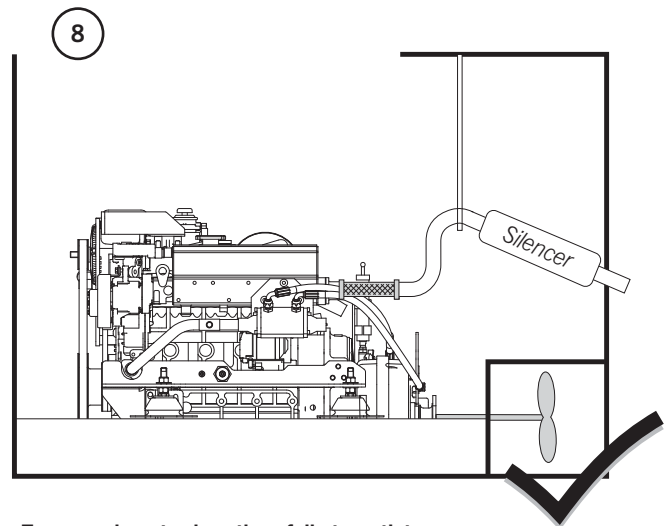
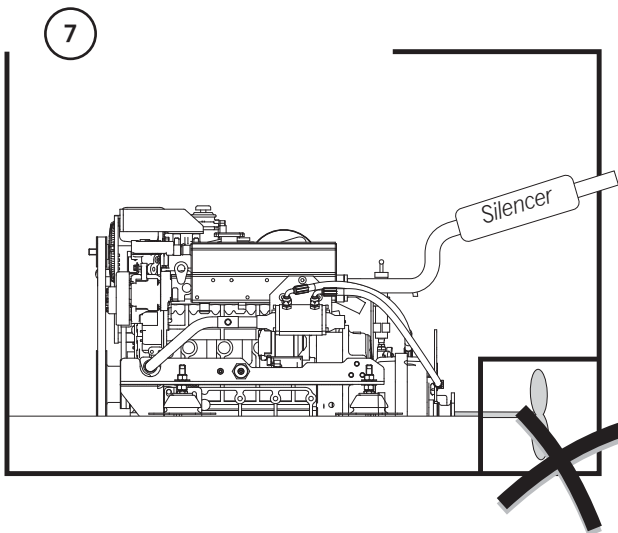

Ensure exhaust raises then falls to outlet

Engine Connections

Actual Connector:	Required Pipe Size:
Fuel supply and fuel leak-off connections are 8 mm conex with olives	8 mm O.D piping for both with flexible section
Seawater cooling pump connections are 28 mm OD	Engine Inlet = 28 mm I.D hose
Water injected exhaust elbow outlet 60 mm OD	Flexible exhaust rubber pipe to correct quality - 60 mm OD

Fuel supply & leak off

9

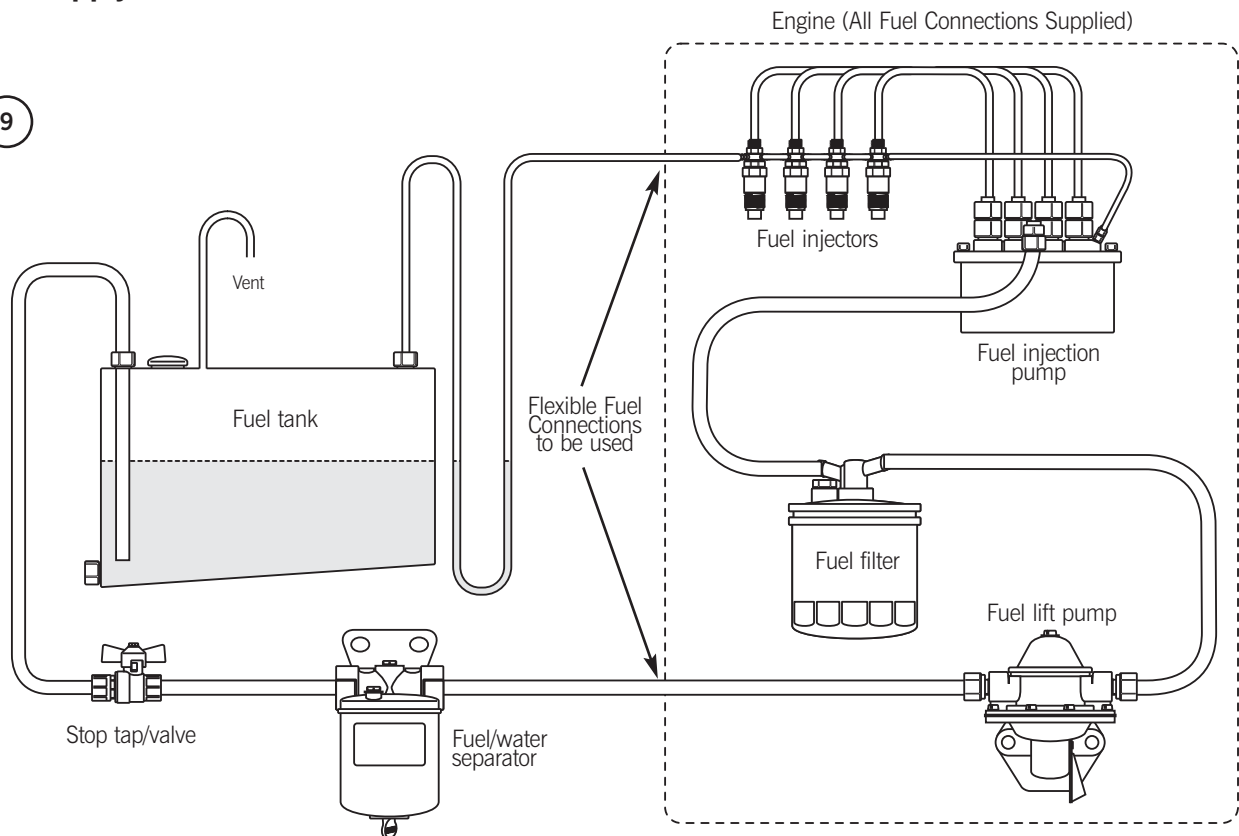

Notes:

- 1) **A fuel/water separator must be installed.**
- 2) The mechanical fuel lift pump is fitted to all engines as standard, but if a suction head of 0.25m or more is required, then an electric fuel lift pump must be fitted (ask your dealer or Beta Marine).
- 3) It is very important that the excess fuel from the injectors is fed back to the fuel tank and not back to any point in the supply line. This will help prevent air getting into the system.
- 4) The fuel return (leak off) pipe must loop down to be level with the bottom of the tank before it enters the top of the tank – see drawing. This prevents fuel 'drain down'.
- 5) Fuel lines and hoses connecting the fuel tank to the engine, must be secured, separated and protected from any source of significant heat. The filling, storage, venting, fuel supply arrangements and installation must be designed and installed so as to minimise the risk of fire. When connecting the engine to the fuel supply and return lines, flexible fuel hoses must be used (next to the engine) and must meet the requirements set in standard ISO7840:1995/A1:2000 and/or as required by your surveyor / authority.
- 6) Any fuel leaks in the system when static are likely to cause poor starting and erratic running and must be corrected immediately. These leaks will allow air to be sucked in when the engine is running.

Seawater Inlet System (Heat exchanger Cooled Engines)

Your engine is fitted with a gear driven sea water pump which sucks in seawater (raw water) to cool the closed circuit system via the heat exchanger.

1. It is very important that the seawater inlet should have a strainer system either built into the sea cock or a high level system with visual inspection glass (as shown) mounted just above the water line.
2. The inlet sea cock should be 1 $\frac{1}{8}$ " , 28 mm ID minimum to suit the 22 mm ID hose.
3. Good access to the inlet sea cock is essential so that plastic bags or seaweed trapped in the intake can be poked out.
4. All pipe work should have approved marine grade stainless steel hose clips. Any loose clamps or bad connections can cause flooding and sinking of the vessel.

It is accepted practice that two stainless steel clips should be used on all raw water pipes for security. Ensure that you use the correct grade of hose.

5. If water is required for stern tube lubrication then this should be taken from a 'T' piece in the pipe going from the heat exchanger outlet to the water injection bend.
6. Scoop type water pickups should **never** be used, as water will be forced through the pump and into the exhaust system whilst the vessel is sailing. This is very dangerous as the exhaust will eventually fill and sea/raw water will back up into the engine through the exhaust valve. Catastrophic failure will result as soon as the engine is restarted. **Note:** The maximum lift of the sea water pump is 2m when primed.

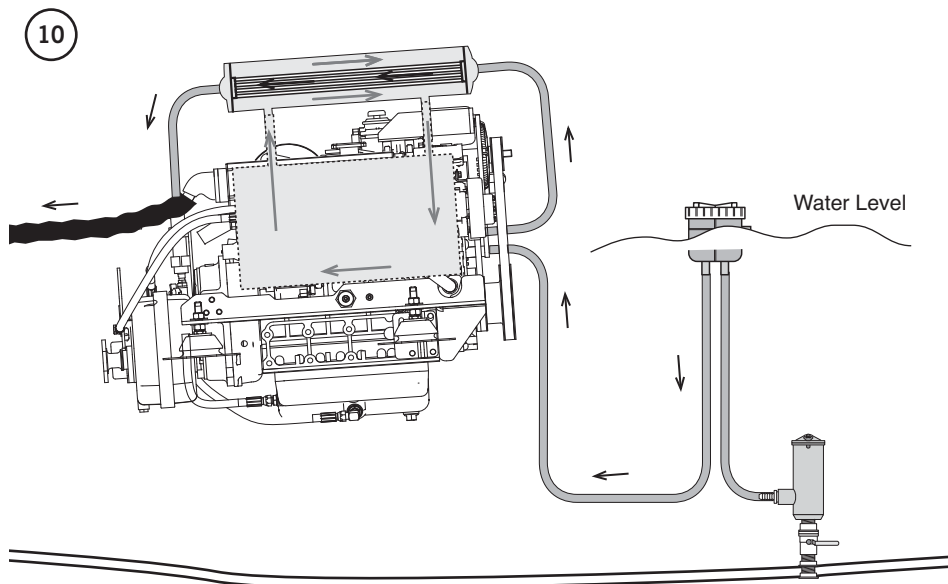

Canal Boats with Keel Coolers

Keel cooling is available as an option with all our engines. Most narrowboats on English canals have keel cooling. Some estuaries and ports have fine silt and mud that block normal heat exchanger cooling systems, requiring a keel cooling solution also for some work boats, etc.

The Beta 75 and Beta 90 propulsion engines arranged for keel cooling have both engine supply and return copper pipes of 32mm diameter; requiring flexible rubber hoses with a 32mm bore. These rubber hoses should be designed and manufactured as hot water heater hoses suitable for operation up to 100 degrees centigrade

Narrowboats: With keel cooling the coolant (same fresh water / antifreeze solution as heat exchanger cooling) flows around the engine and also the keel cooling tanks, before returning to the engine. These keel cooling tanks are normally welded into the 'swim' of the narrowboat, using the 8mm steel plate hull as one side of the tank to transfer the engine heat to the canal. The required surface area for keel cooling our engines in narrowboats is as detailed.

11

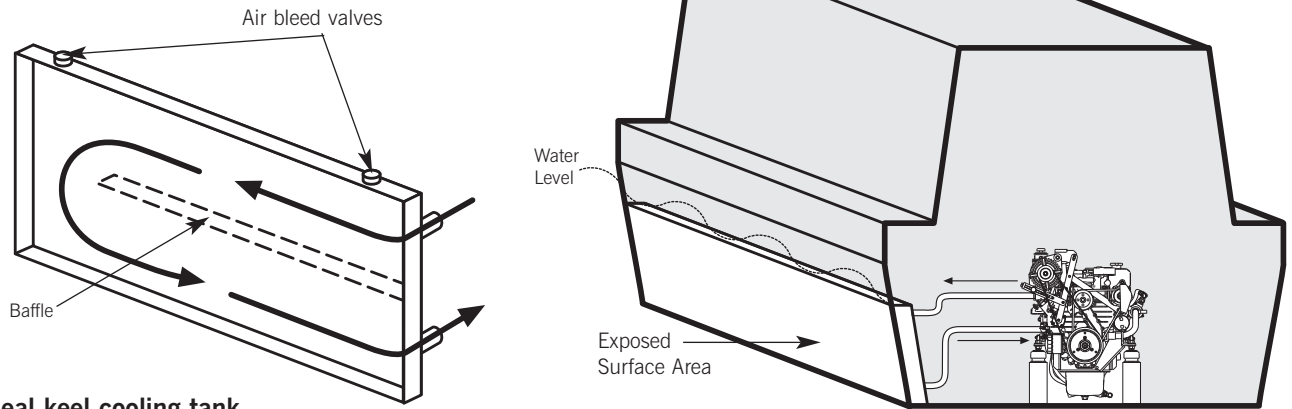

Ideal keel cooling tank

The keel cooling tank size should have a surface area exposed to the canal or sea water of: $0.25 \times \text{the bhp of the engine} = \text{the square feet of cooling area required (for steel hulls)}$.

Efficient keel cooling tanks are side mounted, see illustration. The ideal keel cooling tank should have:

- a) The 'baffle' continuously welded to the outer skin and should be close fitting to the inner skin.
- b) The tank should be thin in section (30mm to 40mm) as it is the heat transfer to the canal or river water that is important.
- c) The tank must have air bleed valves fitted on the top at both ends of the tank

Keel cooling pipes under the hull of yachts or work boats, that achieve the same surface area can also be used. If you have any questions about keel cooling please refer to our design guidelines detailed on our website, or ask us.

Engine Model	Steel Tanks Size (ft)	Steel Tanks Size (m ²)
Beta 14	3.5	0.33
Beta 16	4.0	0.38
Beta 20	5.0	0.46
Beta 25	6.3	0.59
Beta 28	7.0	0.65
Beta 35	8.8	0.82
Beta 38	9.5	0.88
Beta 43	10.8	1.00
Beta 50	12.5	1.16
Beta 60	14.0	1.30
Beta 75	18.8	1.75
Beta 90	22.5	2.10
Beta 120	30.0	2.40

12

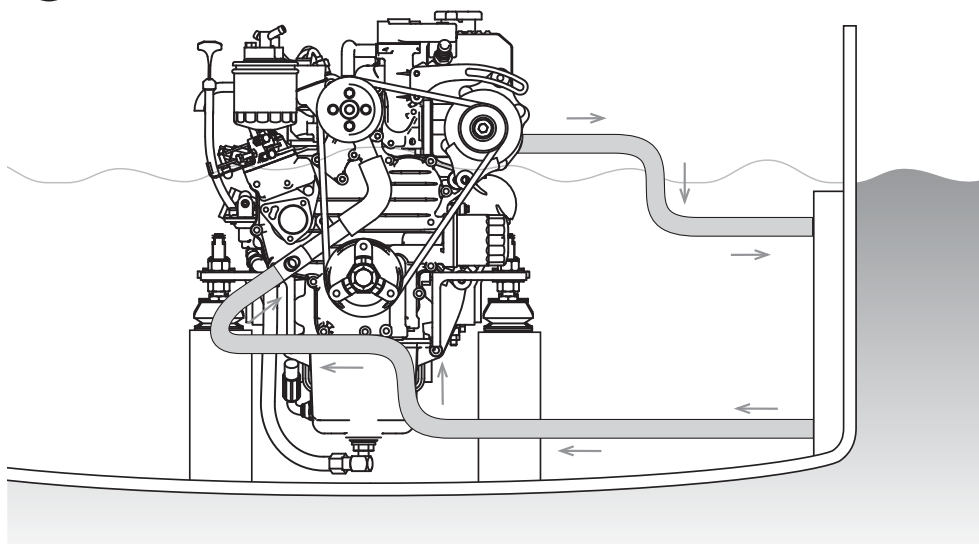

Calorifier System

All Beta engines can be fitted with the calorifier connections to allow the hot water from the closed fresh water / antifreeze system to circulate through a calorifier tank, which in turn heats up domestic water. Calorifier connections on this range of engine are shown.

1. The big problem with a calorifier is to remove all the air from the system. If this is not achieved then they don't work!
2. Try and keep the supply and return pipes either horizontal or sloping down in a continuous fall towards the calorifier. This avoids air pockets being created.
3. Extra care must be taken when first filling the calorifier circuit system with 50% antifreeze to water solution as the engine may appear to be full but it soon disappears into the calorifier pipe work. Run the engine off load for 10 minutes then check the level as described in 'Filling The Fresh Water System'. Also check to see if the pipe going to the calorifier is getting warm. Top up the water level as required and run for another ten minutes then repeat.
4. If the water level is steady but no warm water is getting to the Calorifier then (with engine stopped) very carefully remove the pressure/filler cap using a large rag/cloth to protect you hand from scalding. Now very carefully open the Calorifier bleed valve (see manufacturers instructions) or if none is provided then very carefully loosen the jubilee clip securing the supply pipe to the Calorifier. Air should escape. Refasten securely when no further bubbles are seen.

Caution: Do not do this when the engine is hot as scalding hot water may be forced out of the pipe.

13

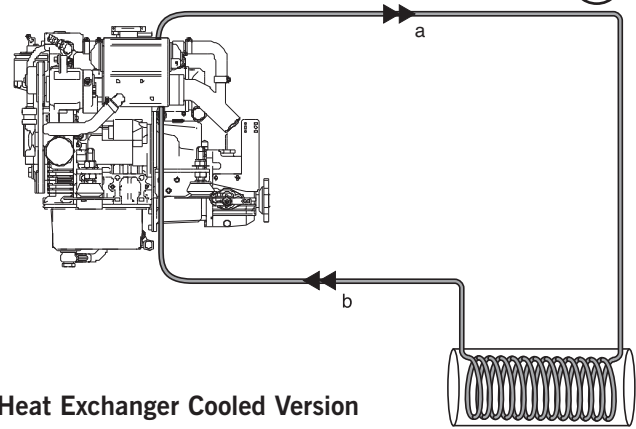

Heat Exchanger Cooled Version

14

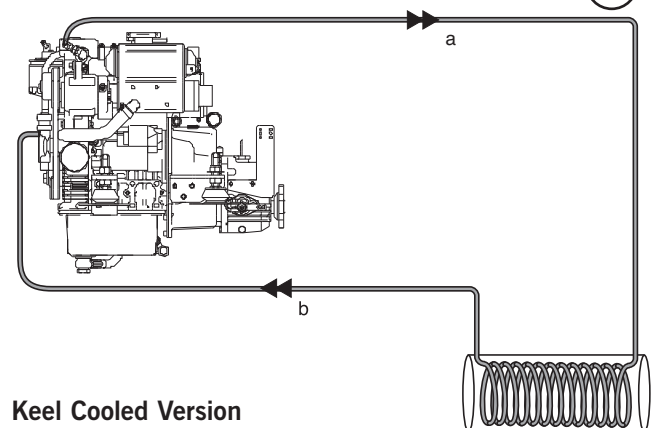

Keel Cooled Version

Heat Exchanger Calorifier System

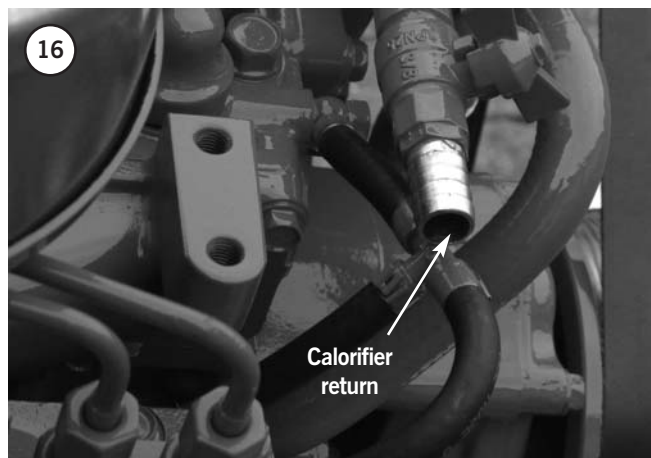
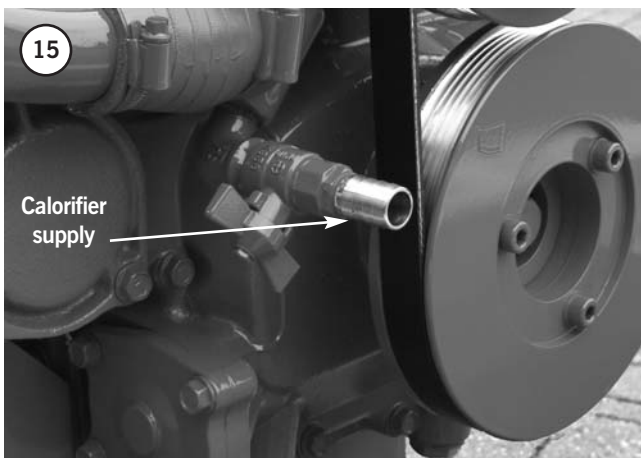

Electrical Installations

Beta Marine have 6 control panels: A, AB, ABV, ABVW, B or C.

The Beta 75 and Beta 90 use the ABV, ABVW, B and C control panels.

The engine harness is common to all.

1. These control panels must not be installed where sea water spray can get at them. A suitable flap or cover must be fitted.
2. Control Panels must be fitted in a location where the helmsman can either see or hear the alarm system.
3. For standard wiring diagrams see pages 39 to 63.
4. Our standard wiring harness has a 3 metre loom. As an optional extra, Beta can provide various lengths of extension looms for runs of over 3m, but this kit includes a start relay to overcome the voltage drop (See drawing 300-58520).
5. All electrical equipment must be protected from sea water. Sea water or rust in the starter will invalidate the warranty. Care must be taken when pushing the two halves of the plug together to ensure that individual pins do not fall out.
6. All cables must be adequately clipped and protected from abrasion.
7. Electrical systems shall be designed and installed so as to ensure proper operation of the craft under normal conditions of use and shall be such as to minimise risk of fire and electric shock.
8. Attention shall be paid to the provision of overload and short circuit protection of all circuits; except engine starting circuits, supplied from batteries.
9. Ventilation shall be provided to prevent the accumulation of gases, which might be emitted from batteries. Batteries shall be firmly secured and protected from ingress of water.

Typical Starter Motor Ratings

Starters used in Kobuta engines have the following standard capacities:

Engine	Starter Capacity (kW)
Less than 700cc	0.8 - 1.0
700 to 1,500cc	1.0 - 1.4
1,500 to 3,000cc	1.4 - 2.0
Over 3,000cc	2.0 - 3.0

Suggested Minimum Engine Starter Battery Size

Engine	Typical Battery Capacity (AH) at a 20hr Rate	Typical C.C.A Cold Cranking Amperage
Beta 10, Beta 14, Beta 16, Beta 20	35 - 50 AH	350 - 400
Beta 25, Beta 28, Beta 35, Beta 38, Beta 43	65 - 75 AH	450 - 540
Beta 50, Beta 60	100 - 120 AH	580 - 670
Beta 75, Beta 90	150 - 180 AH	1050 - 1200

To prevent corrosion and assist in assembly we recommend that the plug is packed with petroleum jelly (Vaseline) and then carefully pushed together. The plastic boots should cover both halves and overlap. A cable tie is then put around to hold the two halves in position and help prevent any ingress of water.

Keyswitch Terminations

The standard panel keyswitch can be used to tap off a switched positive ignition feed to power additional gauges. In this way these gauges will only be live whilst the engine is running, the engine is starting or the heaters are being used. For silver keyswitches, the terminal to achieve this ignition switched positive is marked 'AC'. For panels without any keyswitch, gauges can be driven from the 1 mm² brown wire which terminates at 11 way connector terminal 4. This is a lower power switched positive, any additional power required from this connection must be feed through a relay, as noted below.

Note: these keyswitch terminals are rated at 10 amps maximum, since they are already utilised for panel and alternator feeds Beta Marine recommend any additional requirements from these terminals must be fed through a relay. This relay should then be connected to it's own fused positive supply directly from the engine battery. Beta drawing 202-06421 illustrating the wiring of a typical electric fuel lift pump with ignition switched relay can be supplied upon request.

Section 2

Guidelines for Operation of Engine

Important Checks Prior to Initial Use

1. Generally, a new engine has the oil and anti-freeze removed after the works test. Fill the engine with the correct oil and antifreeze (see sections on Engine oil and Cooling). **Check gearbox oil level** - see gearbox 'Owners Hand Book'.
2. Ensure the engine is free to turn without obstructions.
3. Ensure battery is fully charged and connected with the battery isolator in the 'ON' position.
4. Ensure "Morse" speed and gearbox cables are fitted correctly and that cable travel lengths are correct.

Gear selection lever - all mechanical gearboxes: care must be taken to ensure that the remote control cable is adjusted so that the selector lever on the gearbox moves FULL travel and brought "hard up" against its end stop in both directions. Failure to achieve the correct adjustment will reduce efficiency of the clutch and may cause slippage at low revs. Warranty will not be accepted on gearboxes returned in the warranty period for failure due to incorrect adjustment.

5. Open the sea water cock.
6. **Bleeding the fuel system for initial start up.**
 - a) Open the fuel stop tap/valve and bleed the fuel/water separator of air as shown in manufacturer's literature.
 - b) Fuel should now be at the fuel lift pump and fuel filter.



- c) Open fuel bleed screw on fuel filter by 1 to 2 turns, see photo 12.

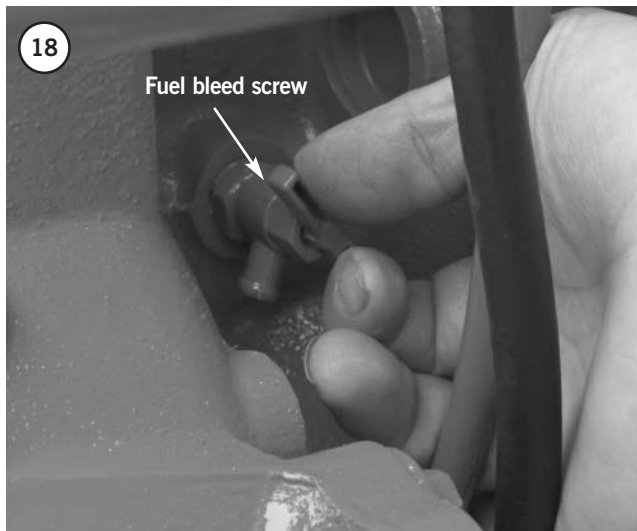

- d) Move the hand priming lever on fuel pump up and down (see photo 17) until fuel with "no bubbles" comes out of the bleed screw (see photo 18). The hand priming lever normally has about 90° travel; **but the camshaft lobe may block this travel requiring you to rotate the engine to obtain full travel.**
 - e) Shut/tighten the bleed screw. Clean area thoroughly with tissue paper.
 - f) Continue to hand prime for 30 seconds to push fuel through the fuel pump.
7. Ensure engine is **out of gear** and set to 1/3 throttle - see "single lever control" instructions/manual.
 8. Start engine (see normal starting). Note the engine may have to be turned over with the starter for a few seconds before it fires. Do not run the starter for more than 20 seconds. If the engine has not started after 20 seconds then disengage the starter and continue to hand prime for a further 30 seconds, then repeat. If engine does not start after 3 attempts then allow 5 minutes for the starter to cool down before repeating (c) to (h). **Note: The starter motor windings can be burnt out with continuous cranking.**

Caution. To avoid personal injury:

- Do not bleed a hot engine as this could cause fuel to spill onto a hot exhaust manifold creating a danger of fire.
- Do not mix petrol/gasoline or alcohol with diesel fuel. This mixture can cause an explosion.
- Do not get diesel fuel or oil on the flexible mounts - they will deteriorate rapidly if soaked in these.
- All fuel must be removed from skin to prevent infection.

Normal Starting

Beta Control Panels - A, AB, ABV, B and C Deluxe - with keyswitch.

To operate the engine: with the engine out of gear, set speed control lever to 1/3 throttle.

- 1) Turn key anti-clockwise to 'HEAT' position and hold for ten seconds.
- 2) Turn key clockwise to 'RUN' position. At this stage the instrument panel should illuminate:
 - Red lamp for 'low oil pressure' should illuminate.
 - Red lamp for 'high engine temperature' should not illuminate (when engine is cold / cool / warm). This lamp will only ever illuminate if the engine is over temperature.
 - Red lamp for 'no starter battery charge' should illuminate.
 - Red lamp for 'no domestic battery charge'. **Only fitted with panels AB and C and will illuminate only if 2nd 'domestic' alternator is fitted.**
 - Green lamp for panel 'power on' should illuminate.
 - Buzzer should sound.
- 3) Turn to 'START' position and engine will motor, hold in position until engine fires (see initial start-up section for maximum time starter can be used).



- 4) Release key (when engine has started) to 'RUN' position.
 - All red warning lamps should extinguish and buzzer should stop sounding. The oil pressure lamp may take a few seconds to switch off and the charge fail lamp may remain on until engine rpm is increased to approximately 1,000rpm if the engine was started on tickover.
 - Green lamp for 'panel power on' should still function.
 - If the 'charge fail' lamp remains on then "blip" the engine speed up to 2000 rev/min and it will go out (split charge relay drain).

Beta Control Panel ABVW - Keyless (without keyswitch)

This panel controls the engine with three water resistant push buttons instead of a keyswitch, and is less prone to damage and corrosion from sea water spray.

To operate the engine: with the engine out of gear, set speed control lever to 1/3 throttle.

- 1) Press and hold 'HEAT' button for ten seconds maximum.
 - Red lamp for 'no starter battery charge' should illuminate.
 - Red lamp for 'high engine temperature' should not illuminate (when engine is cold / cool / warm). This lamp will only ever illuminate if the engine is over temperature.
 - Red lamp for 'low oil pressure' should illuminate.
 - Green lamp for panel 'power on' should illuminate.
 - Buzzer should sound.
- 2) Press 'START' button and hold in position until engine fires (see initial start-up section for maximum time starter can be operated). Release button (when engine has started)
 - All red warning lamps should extinguish and buzzer should stop sounding. The oil pressure lamp may take a few seconds to switch off and the charge fail lamp may remain on until engine rpm is increased to approximately 1,000rpm if the engine was started on tickover.
 - Green lamp for 'panel power on' should still function.



- 3) To stop the engine press the 'STOP' push button, hold in until engine stops. This button also switches the power off to the gauges, engine and 'power on' lamp.
- 4) To re-start the engine, simply repeat steps from '1' above, there is no need to switch battery isolators off whilst remaining on board.
- 5) If leaving the boat, isolate start battery from engine and panel, to prevent accidental start up of engine and stop power leakage.

Stopping

Every propulsion engine is fitted with a stop solenoid. To stop the engine simply press stop push button, hold in until engine stops, then turn key from 'RUN' to 'OFF' position. Do not turn the key to the off position when the engine is running, this will not allow the alternator to charge the battery.

Warning!

Do not leave the key in 'HEAT' position for more than 15 seconds - this will damage the heater plugs and eventually lead to poor starting.

When leaving the boat for an extended period:

- Turn off sea-cock (heat exchanger cooled engines).
- Turn off battery isolator.

Notes for all panel types: Do not depress the stop button for more than ten seconds as this will lead to overheating and failure of the solenoid. These engines are equipped with a mechanical stop lever in the event of electrical system failure. This lever is located on the starboard side of the engine below the speed control lever. See illustration below. Move the stop lever aft to stop the engine then return it to the run position.

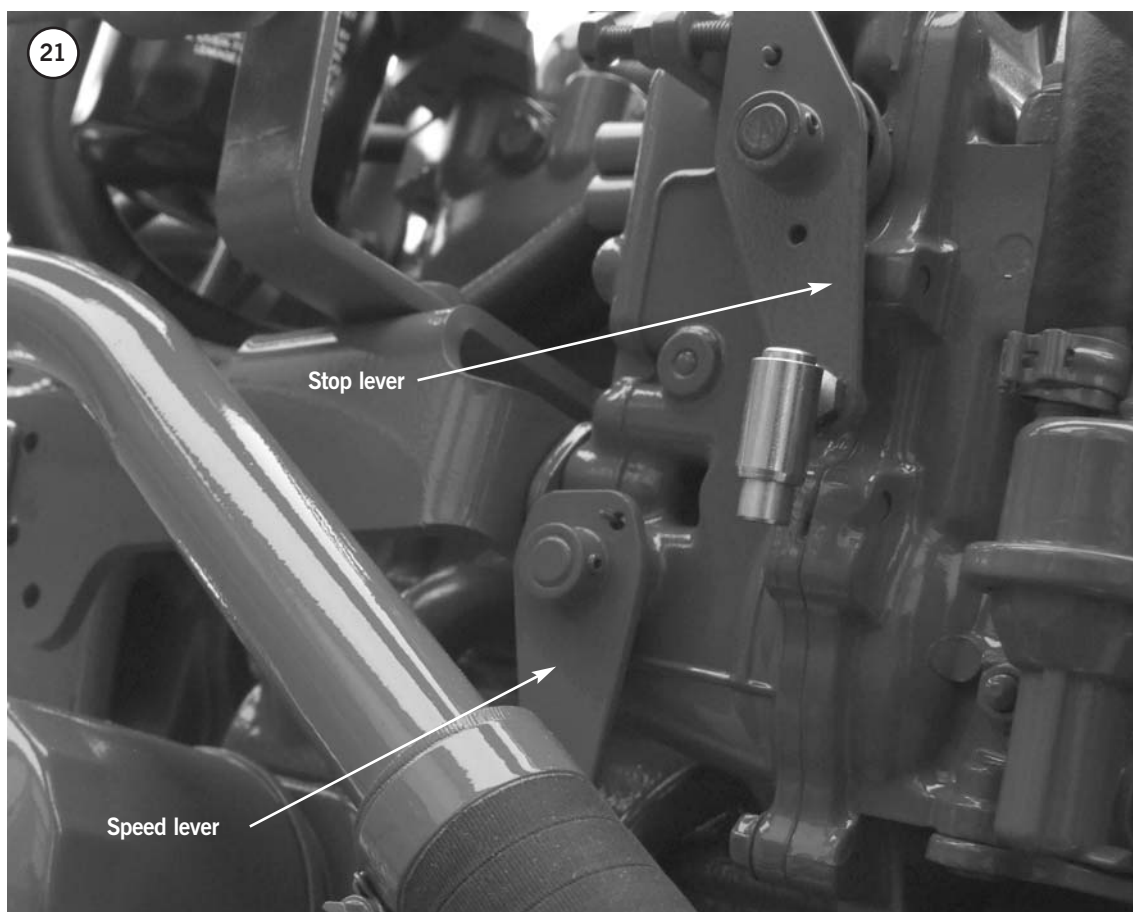

Section 3

Maintenance Schedule

Daily or every 8 hours running

- Check engine oil level.
- Check gearbox oil level.
- Check coolant level.
- Check battery fluid.
- Check drive belt tension
- Ensure raw water inlet strainer is clear.
- Check stem gland lubrication (if used).
- Drain off any water in fuel/water separator.

After the first 25 hours running

- Change gearbox lubricant (See separate gearbox manual).
- Check that all external nuts, bolts and fastenings are tight. See table for torque values. **Do NOT over tighten.** Special attention should be paid to the flexible mount lock nuts, these should be checked for tightness, starting with lower nut first in each case. If the lower nuts are found to be very loose, then the alignment of the shaft to the gearbox half coupling should be re-checked. Poor alignment due to loose flexible mount nuts will cause excessive vibration and knocking.
- Check the belt tension on any second alternators fitted and adjust, see page 11.
- Check ball joint nyloc nuts for tightness on both gearbox and speed control levers. Grease both fittings all over.

After first 50 hours

- Change engine lubricating oil.
- Change oil filter.
- Check for leaks on header tank tubestack. Tighten end cap bolt if required.
- Drain off any water in fuel/water separator.

Every year or 250 hours if sooner

- Change engine lubricating oil
- Change lubricating oil filter
- Check air cleaner element
- Check sea water pump impeller and change if worn.
- Check wasting anode condition, replace when necessary. In some environments this may be six monthly or less.
- Remove heat exchanger tube stack, by undoing the bolt each end of the tube stack. Remove end cover, pull out tube stack and clean. Replace rubber 'O' rings and re-assemble. Top up with antifreeze. Immediately engine is started check for leaks.
- Spray the key switch with WD40 or equivalent to lubricate the barrel.
- Check that all external nuts, bolts and fastenings are tight. See table for torque values.
- Check ball joint nyloc nuts for tightness on both gearbox and speed control levers.

Every 750 hours (In addition to 250 hours maintenance)

- Change air cleaner element.
- Change fuel filter.
- Change antifreeze.
- Change gearbox oil.
- Check electrical equipment, condition of hoses and belts, replace as necessary.

Maintenance Schedule

	Daily or every 8hrs running	After first 25hrs	After first 50hrs	Every Year or 250hrs if sooner	Every 750hrs
Check engine oil level	●				
Check gearbox oil level	●				
Check engine coolant level	●				
Check battery fluid	●				
Check drive belt tension	●				
Ensure raw water inlet strainer is clear	●				
Check stern gland lubrication	●				
Drain off any water in fuel / water separator	●				
Change gearbox oil		●	See separate gearbox manual		
Check all external nuts, bolts and fastenings are tight. Check belt tension. Check for leaks		●	●	●	●
Change engine oil			●	●	●
Change oil filter			●	●	●
Lubricate keyswitch on control panel with "vaseline" or WD40			●	●	●
Check coolant "sacrificial" zinc anode and replace if necessary - sometimes frequently			●	●	●
Check general condition			●	●	●
Remove heat exchanger tube stack and replace rubber O-rings				●	●
Check sea water pump impeller and change if worn				●	●
Check air cleaner element and change if required				●	●
Change air cleaner element					●
Change diesel fuel filter					●
Change gearbox oil					●
Drain and replace engine coolant / anti-freeze					●

Lubrication

Engine oil: Engine oil quality should have the minimum properties of the American Petroleum Institute "API" classification CF (CD, or CE). The following table gives grades of oil viscosity required for various ambient temperature ranges.

Note: A good quality SAE 15W/40 mineral based multigrade oil as used in most car diesel engines will meet requirements.

Do not use 'Turbo Diesel Oil' or additives, and the use of synthetic oil is not recommended.

Ambient Temp.	Single Grade	Multi-Grade
-30°C to 0°C	SAE 10W S	AE 10W/30
-15°C to +15°C	SAE 20W	SAE 15W/40
0°C to +30°C	SAE 30	SAE 15W/40
25°C and above	SAE 30	SAE 15W/40

Checking engine oil level

For quantities of oil required see section marked 'Technical Specification', page 4.

When checking the engine oil level, do so before starting, or more than five minutes after stopping.

1. To check the oil level, draw out the dipstick, wipe it clean, re-insert it, and draw it out again. Check to see that the oil level lies between the two notches.



2. If the level is too low, add new oil to the specified level - **Do not over fill.**

Important: When using an oil of different make or viscosity from the previous one, drain old oil. Never mix two different types of oil. Engine oil should be changed after first 50 hours running time and then every year or every 250 hours if sooner. Oil filter is a cartridge type mounted on the starboard side of the engine.



Changing engine oil

- (1) Run the engine for 10 minutes to warm up the oil.
- (2) Your engine is provided with a sump drain pump. Unscrew the end cap on the end of the pump spout, turn the tap to 'on'. Use the hand pump as shown to pump out the oil into a bucket. Turn the tap to off position and replace end cap. See photo 24.
- (3) Unscrew the oil filter and replace with a new one. See photo 25.

Note: It is best to have a plastic bag wrapped round the filter to catch any oil left in the system. (Always keep your bilges clean!) Before screwing in the new filter spread a thin film of oil round the rubber gasket to ensure a good seal and screw in - hand tight.

- (4) Fill the engine with new oil as described on the previous page.
- (5) Run the engine and check for oil leaks.

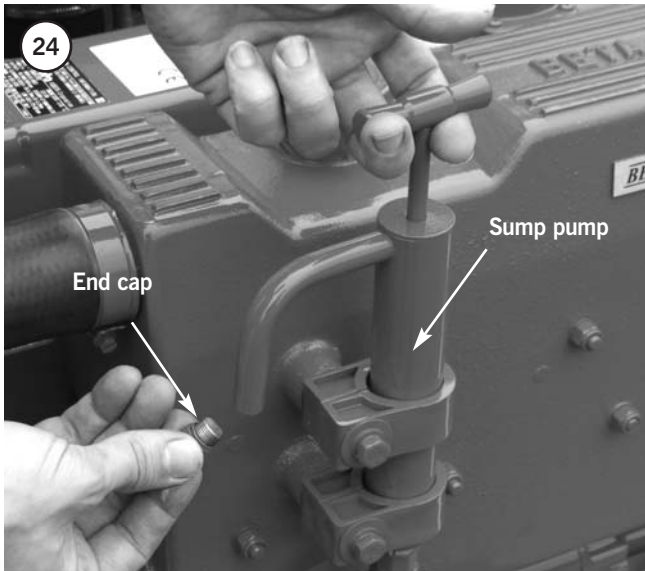

Checking Gearbox oil level

- 1) The gearbox is fitted with a dipstick and oil filler plug, see photo 26.
- 2) Each engine is supplied with a gearbox 'operators manual' which specifies the type of lubricating oil to be used, the capacity and frequency of changing of the oil.
- 3) New engines are normally supplied with the gearbox topped up with lubricant but **check the level before starting the engine for the first time.**
- 4) The oil can be changed via the drain plug at the bottom of the box or sucked out with a hand pump via the filler plug.
- 5) A guide to the type of oil to be used is as follows:

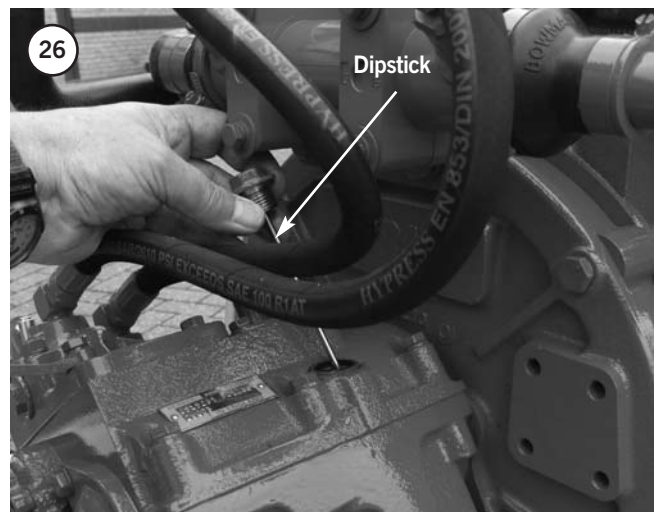

Gearbox	Lubricant	Capacity (approx.)
ZF25M	Use ATF Oil	1.50 litres
ZF25H	Use ATF Oil	0.75 litres
PRM260	Use Engine Oil 15W40	2.00 litres
PRM500	Use Engine Oil 15W40	2.50 litres

Note: ATF is Automatic Transmission Fluid. For additional information see: www.prm-marine.com

Fuel System

Important

- Always fit a fuel/water separator in the fuel supply system. **Water in the fuel can seriously damage the injection system.**
- If a fuel supply shutoff valve is fitted do not use a taper tap, only use a ball valve tap. The ball valve type are more reliable and less likely to let air into the fuel system.
- Be sure to use a strainer when filling the fuel tank. Dirt or sand in the fuel may cause trouble in the fuel injection pump.
- Always use diesel fuel. **Do not use paraffin / kerosene**, which is very low in cetane rating, and adversely affects the engine.
- Bio-diesel fuel can be added to the normal diesel fuel up to a maximum limit of 5% without affecting the warranty.
- We know that some customers are using 100% Bio-diesel fuel, **Important**; Beta Marine warranty will not cover fuel equipment when more than 5% Bio-diesel is used. If you use Bio-diesel fuel you must fit an electric lift pump into the fuel supply line and the fuel filter and oil filter must both be changed together when the oil filter is normally replaced.
- Be careful not to let the fuel tank become empty, or air can enter the fuel system, necessitating bleeding before next engine start.
- The fuel lift pump will only lift fuel through 0.25m. If this is insufficient then an electric fuel lift pump must be fitted. Drawing 202-06421, illustrating recommended wiring for this pump can be supplied upon request.

Fuel Filter Replacement

1. The fuel filter is a spin on type. Remove by turning anti-clockwise when viewed from below.
2. Replace the fuel filter cartridge every 750 hours or every 2 years. See photo 27.
3. Apply fuel oil thinly over the gasket and tighten into position - hand tight.
4. Bleed as detailed - see 'initial start up'.
5. Check for leaks.
6. Do not get fuel on the flexible mounts, this will degrade the rubber.

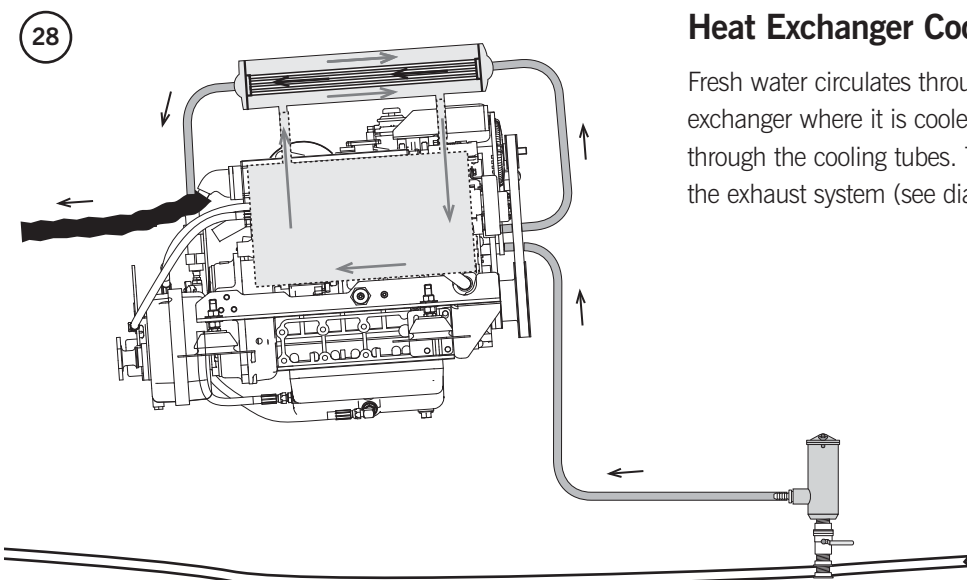

Heat Exchanger Cooled

Fresh water circulates through the engine and on to a heat exchanger where it is cooled by sea water which is pumped through the cooling tubes. The sea water is then injected into the exhaust system (see diagram).

Filling the Freshwater System

New engines are supplied with the freshwater drained off. The following instructions must be followed to fill the system.

- (a) Mix up in a clean bucket a 33% to 50% anti-freeze to freshwater solution (see page 10). For the volume required see technical specification page 4.
- (b) With Beta 75 and Beta 90, check that the drain tap or plug is turned off, see photo 29.



- (c) Fill engine with freshwater / anti-freeze solution through the top of the heat exchanger or header tank with the filler cap removed. See photo 30.



- (d) Fill header tank to the top of the filler neck and replace cap. Press down firmly on filler cap and hand tighten in a clockwise direction.
- (e) Run the engine for 5 minutes on no load (out of gear) and check coolant level. Top up as necessary.
- (f) Check system for leaks.
- (g) If a calorifier is fitted care must be taken to see that this is also full of coolant and all the air is expelled. (See calorifier fitting notes under Section 1).
- (h) Run the engine on one third load for 15 minutes, preferably with the boat tied up. As the system warms up coolant may be expelled from the overflow pipe into the bilge. Stop the engine and allow the engine to cool down before removing the pressure cap and top up the coolant to 1" below the filler neck.

Important: Removal of the pressure cap when the engine is hot can cause severe injury from scalding hot water under pressure. Always allow the engine to cool and then use a large cloth when turning the cap anti-clockwise to the stop. This allows the pressure to be released. Press firmly down on the cap and continue to turn anticlockwise to release the cap.

- (i) Repeat (h) if coolant level is more than 1 inch below the base of the filler neck when the engine has cooled down.
- (j) Run engine on $\frac{2}{3}$ full load for 20 minutes, check for leaks and repeat (i).
- (k) Anti-freeze solutions should be drained off every 2 years and replaced with a new solution.

Note: When draining fresh water system, ensure the engine has cooled sufficiently to prevent scalding from hot pressurised water. Prior to draining a cold engine, remove the filler cap from the header tank and then open the water drain tap. This allows the water to drain freely from the system.

Yachts and launches with heat exchanger cooling

It is essential that a solution of fresh water and anti-freeze is used as engine coolant. The amount of anti-freeze must be between 33% to 50%. This not only stops 'freezing up' in winter, but it prevents overheating and corrosion.

**The warranty is invalid unless the correct ratio is used.
The concentration of ethylene must NOT exceed 50%.**

The anti-freeze in the fresh water system enables the boiling point of water to rise to 124°C with a 13 psi pressure cap fitted.

The water temperature alarm switch will however be activated at 95°C to 100°C. If no anti-freeze or a very weak solution is used, then the water temperature switch may not be activated before coolant is lost.

Sea water pump and cooling system

(Heat exchanger-cooled engines)

Caution: Before working on the sea water system ensure that the **sea cock is in the off position**.

- (1) It is very important that the correct sea water flow is maintained to cool the closed circuit system of the engine. The key component in this system is the sea water pump impeller. This should be checked every year by removing the circular plate. See photo 31.
- (2) Withdraw the rubber impeller from its drive shaft as shown. See photo 32.
- (3) Check impeller for cracks in the rubber, excessive wear or lost vanes. Replace with a new impeller as necessary.

Note: If any pieces of rubber impeller are missing then they must be found as they are most likely to be trapped in the entrance to the heat exchanger cooling stack. See 'Cleaning Tube Stack'.

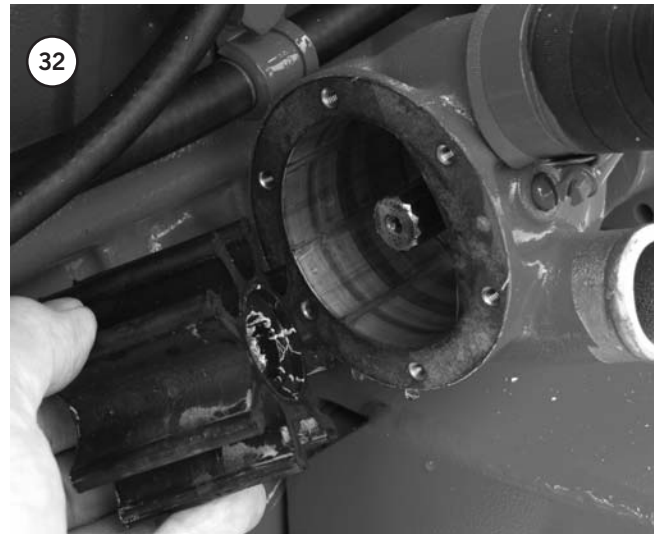
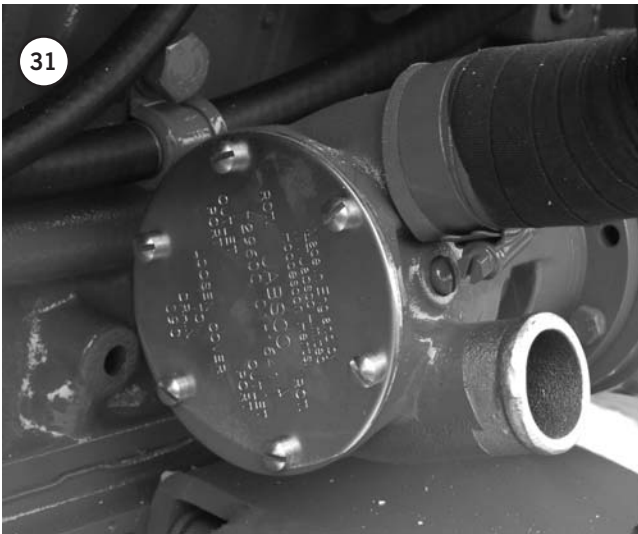

Cleaning the heat exchanger tube stack and replacing 'wasting zinc anode'

- (1) The wasting zinc anode should be checked regularly at least every six months and replaced every year or as necessary. The anode is attached to the bolt inserted in the end cap of the heat exchanger. See photo 33. On most engines this is on the aft end.
- (2) Unscrew the bolt and replace the complete unit with a new one.
- (3) It is possible for fine sea weed and other debris to get past the inlet filter and into the tube stack. This should be removed and cleaned. See photo 34.
- (4) Drain off coolant into a bucket.
- (5) Unscrew the 2 end cap retaining bolts (one each end of the tube stack). Remove the 'O' rings and pull out tube stack. Clean tube stack and end caps.

(6) Re-assemble using new 'O' rings. Do not over tighten end cap bolts and **make sure the tube stack is the right way round** for end cap location.

(7) Re-fill engine with water/anti-freeze solution and run engine up to temperature to check for leaks.

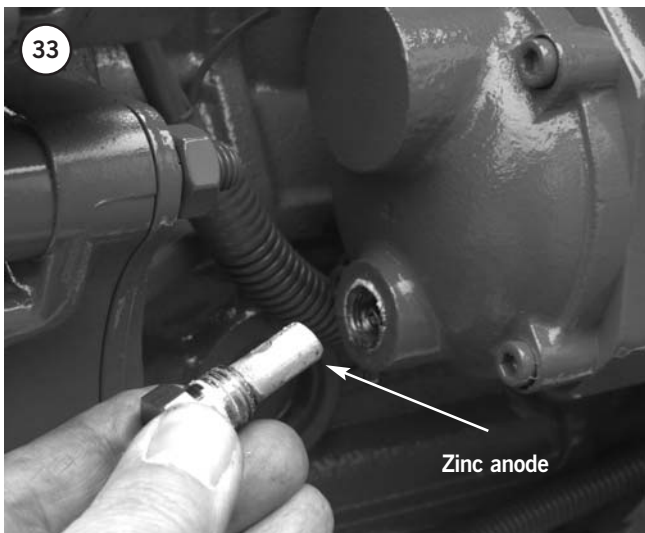

Belt Tension

65 Amp alternator (heat exchanger cooled)

Warning: Belt tension must only be checked with the engine switched off.

- (1) On heat exchanger cooled engines a single 65 amp is fitted as standard. This alternator is adjusted as follows.
- (2) The belt tension is adjusted by swinging the alternator outboard as it pivots on its support bolts. See photo 35.
- (3) With the engine stopped, loosen the support bolts and the link adjusting bolt.

- (4) Push alternator outboard to tension and tighten link bolt. Check that the depression of the belt at position shown is approximately $\frac{1}{2}$ " or 12 mm when pushed down firmly by thumb. Tighten support bolts. See photo 36.
- (5) Belt tension should be regularly checked especially during the first 20 hours of running in a new belt, as stretching occurs.

100 Amp alternator (option)

The same method applies as outlined above, but final tensioning must be by hand only. Over tensioning will cause premature failure of components.

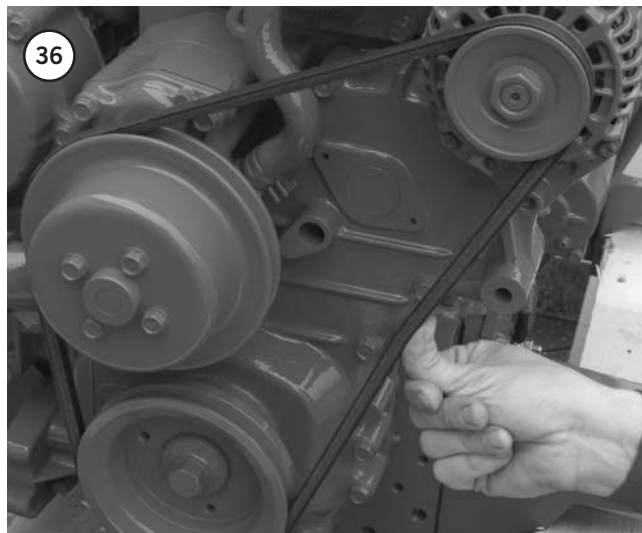
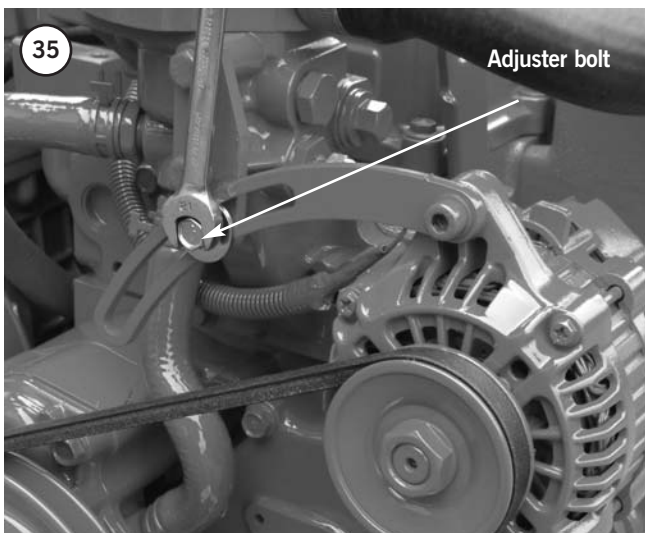

Air Filter Intake

These engines are fitted with an air intake filter which should be checked every season and changed every 2 years or sooner if badly clogged. If badly clogged check more often.

Original Top Mounted Air Filter



Updated Side Mounted Air Filter

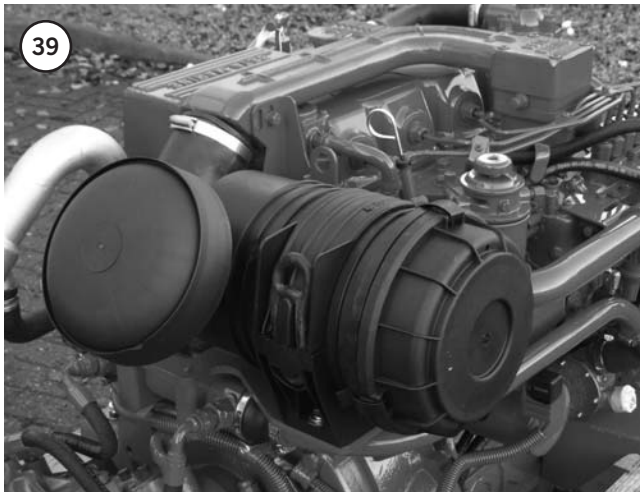

Maintenance - Electrical

Warning:

Under no circumstances should the battery be disconnected or switched off when the engine is running. This will seriously damage the alternator.

Panels and Wiring

See installation notes, page 30.

General maintenance

- (1) The panel must be protected from rain and sea water, see installation. Sea water entering the key switch will eventually cause corrosion and could result in the starter motor being permanently energised and burning out. Spray key switch every month with WD40 or equivalent; or apply 'vaseline'.
- (2) Check batteries for acid level and top up if required. For low maintenance and 'gel' batteries see manufacturers instructions.
- (3) Loose spade terminal connections are the most common cause for electrical faults - check on a regular bases (see maintenance instructions).

Winterising and Laying up

Heat Exchanger Cooled Engines

- a) The engine lubricating oil and lubricating oil filter should be changed at the end of the season rather than in the spring. See section 2.
- b) The closed circuit cooling system must contain an anti-freeze coolant solution. The coolant solution is a mixture of fresh water and anti-freeze (Ethylene Glycol based conforming to BS6580:1992) with the anti-freeze being a minimum of 33% up to a maximum of 50% solution (this also applies to warm and tropical climates). The warranty is invalid if the correct percentage/ratio is not used.
- c) For cold climates where the air or water temperatures can fall below 3°C, the sea water circuit must be protected in addition to the fresh water system. This is best achieved as follows:
 - Close the inlet seacock to the engine (engine stopped).
 - Disconnect the sea water inlet pipe and dip it into a small bucket containing 50/50 anti-freeze solution.
 - Start the engine (out of gear) and run for 5 to 10 seconds until the anti-freeze is used up and can be seen coming out of the exhaust outlet.
 - Shut engine off and reconnect the inlet pipe to the seacock. The sea water or raw water circuit is now protected by anti-freeze.
- d) Ensure instrument panel is well protected and give the key switch a spray of WD40 / Petroleum Jelly or equivalent.
- e) With the engine stopped, disconnect the battery (always disconnect the negative cable first and re-connect the negative cable last) and take it ashore for trickle charging and top up as necessary. If AC power is available then this can be done on the boat.
- f) Fuel tanks should be kept full during the lay up period to eliminate water condensation in the tank. Water entering the fuel injection system can cause considerable damage.

Keel Cooled Engines

The requirements for keel cooled engines are basically the same as heat exchanger cooled except:

- a) Special care must be taken to ensure that the whole cooling system is filled with the anti-freeze solution detailed above; this includes the calorifier circuit and the keel cooling tank. If the system has been topped up or refilled then run the engine for 10 to 15 minutes on load (if possible) to get the solution circulated throughout the keel cooling tank and calorifier.

Laying up Ashore

- a) Change the engine oil before the boat is taken out of the water. Remember that warm engine oil is much easier to pump than cold!
- b) Cooling system - As above in 'Winterising and Laying up' paragraphs (b) to (f) should be followed.
- c) If the engine is to be laid up for more than 6 months then remove the sea water pump impeller.
- d) If the engine will not be used or run for periods longer than 6 months we recommend that the engine is 'inhibited' - this involves running the engine for about 5 minutes to:
 - Replace all the diesel fuel in the fuel system and injection pump by running the engine with 'calibration fluid' (fuel pump test oil ISO 4113).
 - Allow 'Ensis' to circulate around the lubricating oil system by draining out the standard lubricating oil and replacing it with a rust preventative oil such as 'Ensis' or similar.

Trouble Shooting

Beta diesels are very reliable if installed and serviced correctly, but problems can occur and the following list gives the most common ones and their solution.

Problem: Engine does not start but starter motor turns over OK

Possible Cause	Solution
No fuel:	Turn fuel cock on and fill tank.
Air in fuel system:	Vent air (see initial start-up)
Water in fuel:	Change fuel filter and bleed system.
Blocked fuel pipe:	Clean out and bleed system.
Fuel filter clogged:	Change filter and bleed system.
Fuel lift pump blocked:	Remove and replace.
Blocked injector:	Remove and clean.
Fuel return not fed back to the tank:	Re-route fuel return pipe.
Heater plugs not working:	Check wiring to the plugs, and replace plugs if they are burnt out.
Stop solenoid stuck in off position:	Check solenoid is free to return to run position.

Problem: Starter motor will not turn or turns over very slowly

Possible Cause	Solution
Battery discharged:	Charge battery or replace. Check alternator belt tension.
Starter motor flooded with sea water:	Remove and clean or replace.
Wiring disconnected or loose:	Check circuit for loose connections.
Water in cylinders:	Incorrect installation. This is serious - check engine oil for signs of water (creamy-coloured oil). Ring your dealer.
Engine harness fuse blown:	Replace fuse located by starter motor (or above flywheel housing) and check for wiring faults.



Fuse.

Note: For convenience, some engines are supplied with a spare fuse and holder attached to the main engine fuse holder.

Problem: Low power output

Possible Cause	Solution
Propeller is too big:	Change or depitch.
Check gearbox reduction ratio relative to propeller size:	Change.
Blocked fuel filter:	Replace.
Blocked air filter:	Replace.
Air in fuel system:	Check system and bleed
Governor spring incorrectly mounted:	Dealer to adjust.
Single lever control not operating correctly:	Disconnect speed control cable and move the lever by hand. Adjust cable.
The electrical load is too large on start up:	Disconnect or reduce the load.

Problem: Erratic running / hunting

Possible Cause	Solution
Air in fuel supply:	Check supply system for leaks and fix.
Fuel lift pump faulty:	Replace.
Clogged fuel filter:	Replace.
Fuel return not fed back to the fuel tank, or blocked pipe:	Re-route pipe or clean.
Air filter blocked:	Replace.
Worn or blocked injector:	Service injectors.
Engine rpm in gear is too low, this must be 850 min:	Increase engine tick over speed.
Faulty stop solenoid:	Disconnect wiring to solenoid. If running improves check for a wiring fault.
Broken fuel injection pump spring:	Replace, this is usually caused by water in the engine oil/fuel
Fuel suction head is too much:	Fit electric fuel lift pump.

Problem: Hunting at idle

Possible Cause	Solution
Knurled leak-off valve may be closed, or idle adjustment screw may need adjusting:	Open knurled leak-off valve fully, with idle adjustment - speak to Beta Marine for advice - discuss problem.

Problem: Hunting at higher speeds

Possible Cause	Solution
Fuel supply problem:	Change fuel filters and check fuel supply.

Problem: White or blue exhaust gas

Possible Cause	Solution
Engine oil level too high:	Reduce the level.
Blocked injector:	Service injectors.
Piston ring and bore worn or con rod bent due to water ingress, giving a low compression:	Get compression checked by your dealer or Kubota service agent. He will advise action to be taken.
Check that the breather pipe is clear and not obstructed:	Remove and clean out

Problem: Black exhaust gas

Possible Cause	Solution
Blocked air filter element:	Inspect and replace.
Over pitched propeller - engine will not reach its full rpm:	Get the propeller re-pitched if necessary.
Accumulated debris on hull:	Inspect and clean if required.

Problem: Low oil pressure warning light on when underway

Possible Cause	Solution
Oil frothing due to high installation angle or too high oil level:	Refer to Beta Marine for advice

Problem: Low oil pressure warning light on when engine speed is reduced to tick over

Possible Cause	Solution
Faulty switch sender:	Replace.
Engine running too hot:	Check cooling water flow (see section 2 Cooling).
Oil relief valve stuck partially open with dirt:	Remove and clean.
Blocked oil filter:	Change.
Wiring fault:	Check circuit.
Insufficient oil:	Top up and check for leaks.
Problem:	Panel rev counter not working (when fitted).

Problem: High oil consumption

Possible Cause	Solution
Oil leaks:	Check for leaks.
Piston rings worn:	Overhaul required.
Valve stem and guide worn:	Overhaul required.
Piston rings gap facing the same direction:	Shift ring gap position. Service Agent to check.

Problem: Water in lubricating oil - general

Possible Cause	Solution
Core plug pushed out due to frozen block:	Service Agent to check and replace.
Water pump seal damaged:	Service Agent to check and replace.

Problem: Water in lubricating oil - heat exchanger cooled

Possible Cause	Solution
Oil goes "milky" due to seawater entering exhaust manifold:	Check installation - has anti-siphon valve been fitted? Change engine oil and run engine for 10 minutes each time to eliminate any water. Get fuel injection pump and compression checked by Service Agent.

Problem: Water in lubricating oil - keel cooled

Possible Cause

Oil goes "milky" due to water entering exhaust manifold and then into the sump:

Solution

Check installation - has dry exhaust system been fitted correctly, and ensuring rain water cannot enter the exhaust port and run back? (See Dry Exhaust System). Change engine oil and run engine for 10 minutes each time to eliminate any water. Get injection pump checked by Service Agent.

Problem: Engine overheats

Possible Cause

Check coolant level:

Solution

Top up.

Pressure cap loose:

Tighten correctly or replace.

Switch sender faulty:

Replace.

Insufficient restrictions in pipe to calorifier:

Clamp off pipe to confirm.

High exhaust back pressure:

Must not exceed:
60 mm of Hg (2.4" of Hg) @ 2,600rpm.

Keel cooler insufficient size:

Contact boat builder

Problem: Engine overheats - Heat exchanger only

The most common cause of overheating is insufficient seawater flow due to a blocked intake (weed or a plastic bag!). If this happens then clear the blockage. If the problem is not cured then check the system for sea water flow which should be 57 litres / minute minimum at 1,500 rpm as follows:

- (a) With the boat tied up and out of gear run the engine up to 1500 rpm. Hold a plastic bucket over the exhaust outlet for 10 seconds and measure the amount of water collected*. Multiply this value by 6 to give the flow in litres/min. Repeat twice and take an average. If the flow rate is noticeably less than the 57 litre per minute minimum at 1,500 rpm, then:
 - (b) Check impeller in sea water pump - if worn replace.
 - (c) If impeller has a vane missing then this will be lodged either in the pipe to the heat exchanger or in the end of the exchanger. This must be removed.
 - (d) Check flow again as in (a).

***Note:** This operation must only be done in safe conditions, in port and with two assistants. Working from a rubber dinghy is best. The person holding the bucket should take precautions against breathing in the exhaust gasses.

Problem: Engine overheats - Keel cooling only

Sometimes overheating is caused by:

- (a) Not fully venting the engine cooling system of air. It is necessary to remove all air from the cooling system - including the "skin" tanks and (if fitted) the Calorifier and associated piping.
- (b) Incorrectly sized "skin" tanks that have been sized for 'usual' canal use (rather than maximum engine output that can sometimes be required) on fast flowing rivers. An additional "skin" tank may need to be fitted; please refer to our website: Inland waterways - Guidelines: keel cooling tank sizes.

Problem: Battery quickly discharges

Possible Cause	Solution
High load and insufficient running:	Reduce load or increase charging time. Large domestic battery banks subject to high electrical loads will take a considerable time to recharge from a single alternator.
Low electrolyte level:	Top up.
Fan belt slipping - black dust in engine compartment, engine compartment temperature too high:	Adjust tension / replace belt with a high temperature type and / or improve engine compartment ventilation.
Alternator defective:	Check with Agent.
Battery defective:	Replace.
Poor wiring connection:	Check wiring system.

Problem: Morse control cable will not fit

Possible Cause	Solution
Incorrect fitting:	Cables are being fitted the wrong way around, switch over and fit the opposite way.

Problem: Panel rev counter not working (when fitted)

Possible Cause	Solution
No W connection to alternator:	Check output from 'W' connection. Should be about 9V AC
Wiring fault:	Check circuit

Problem: Transmission noise

Possible Cause	Solution
Check gearbox oil level:	Top up.
"Singing" propeller:	Check with propeller supplier about 'harmonics'.
Drive plate rattle at tickover:	Check engine rpm (must be 850rpm min. in gear).
Worn drive plate:	Change.
Propeller shaft hitting the Gearbox half coupling:	Move shaft back to give 5mm - 10mm clearance (Type 12/16 couplings only).
Propeller torsionals causing gears to rattle at low rpm:	Fit a torsional flexible coupling such as Centa type 16 or equivalent.

Problem: Vibrations

Possible Cause	Solution
Poor alignment to shaft:	The alignment must be accurate even if a flexible coupling is used (see section 1, Alignment).
Flexible mounts not adjusted correctly to take even weight:	Check relative compression of each mount.
Flexible mount rubber perished:	Replace. (Diesel or oil will eventually perish most rubbers.)
Loose securing nut on flexible mount:	Check alignment and then tighten the nuts.
Insufficient clearance between the propeller tip and the bottom of the boat:	There must be at least 10% of the propeller diameter as tip clearance between the propeller and the bottom of the boat. Reduce propeller diameter / increase pitch.
Loose zinc anode on the shaft:	Tighten or replace.
Worn cutless bearing or shaft:	Replace.
Weak engine support/bearers:	Check for cracked or broken feet.

Problem: Knocking noise

Possible Cause	Solution
Propshaft touching gearbox output coupling through split boss or Type 16 coupling:	Adjust, giving correct clearance give 5mm - 10mm between gearbox and propeller shaft
Flexible mount stud touching engine bed:	Adjust stud to clear
Drive plate broken:	Replace / repair
Engine touching engine bed:	Re-align engine / modify bed
Injectors blocked through excess carbon caused by water in the fuel:	Remove and check injector nozzles, replace if required.

Electrical Fault Finding & Trouble Shooting - Engines built after July 2005 only

The following chart is compiled to aid diagnosis of electrical faults, based on the Beta 10 - 90hp range of engines. If your engine was built before July 2005, contact Beta Marine for the relevant electrical trouble shooting guide.

Note: our standard control panels are for earth return installations only (where battery negative cable is connected directly to engine ground). For insulated earth (where battery negative cable is isolated from engine ground) different harnesses, alternators, switches for oil pressure and engine temperature are fitted.

Standard sea specification engines (heat exchanger cooled) are supplied with a single alternator, mounted port side, supplying power to starter battery and control panel.

Standard canal specification engines (keel cooled) are supplied with twin alternators:

- 1st alternator, mounted port side, supplying power to starter battery and control panel
- 2nd alternator, the standard mounting position for this is above the engine on the starboard side (or below 1st alternator on 75 and 90hp), supplying power to the domestic battery system.

Both of these alternators work independently, if the domestic battery system is disconnected, the engine will still run correctly but:

- Domestic charge warning lamp will not function
- Warning buzzer will remain on at all times

Note: The two way plug on panel loom will only have a corresponding socket to connect into from the engine if a 2nd alternator is fitted which requires this connection. Engines with only one alternator do not utilise this connection.

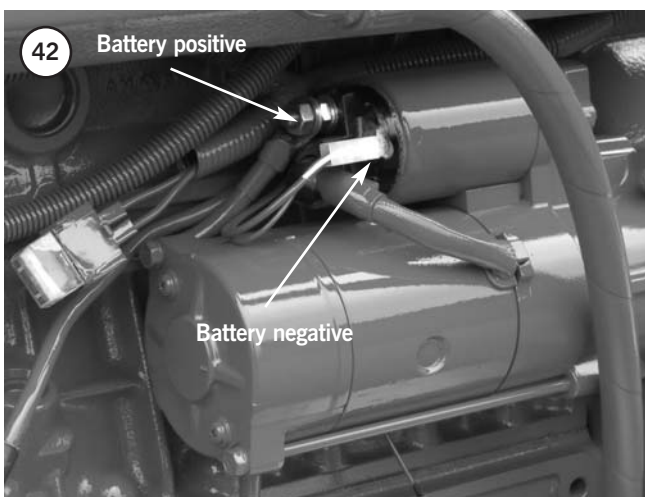

Standard Keyswitch Control Panels are supplied with four or five lamps.

Four lamp panels: A, ABV, B these panels utilise bulbs inside sealed lamp holders.

Five lamp panels: AB and C; these panels also utilise bulbs inside sealed lamp holders, having an additional lamp for 'domestic battery charge'.

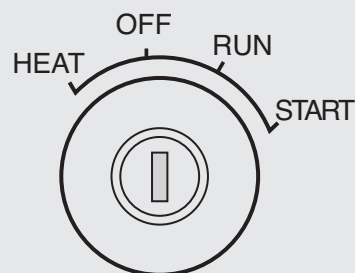

With keyswitch* in run position and engine off:

- Red lamp for 'low oil pressure' should function
- Red lamp for 'high engine temperature' should not function (when engine is cold/cool/warm). This lamp will only ever function if the engine is over temperature.
- Red lamp for 'no starter battery charge' should function
- Red lamp for 'no domestic battery charge' should function (**Note:** this will only function if a second alternator is fitted to the engine and connected to a charged battery)
- Green lamp for 'panel power on' should function
- Buzzer should sound

Electrical Fault Finding & Trouble Shooting - Engines built after July 2005 only

ABVW - Keyless four lamp panel (without keyswitch)

This panel controls the engine with three water resistant push buttons instead of a keyswitch, and is less prone to damage and corrosion from sea water spray. This panel utilises bulbs inside sealed lamp holders

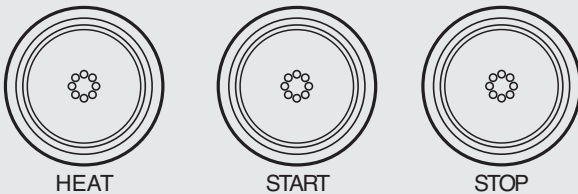

- 1) Press and hold 'HEAT' button for ten seconds maximum.



Red lamp for 'low oil pressure' should function



Red lamp for 'high engine temperature' should not function (when engine is cold/cool/warm). This lamp will only ever function if the engine is over temperature.



Red lamp for 'no starter battery charge' should function



Green lamp for 'panel power on' should function

Buzzer should sound.

- 2) Press 'START' button and hold in position until engine fires (see initial start-up section for maximum time starter can be operated). Release button (when engine has started).



All red warning lamps should extinguish and buzzer should stop sounding. The oil pressure lamp may take a few seconds to switch off and the charge fail lamp may remain on until engine rpm is increased to approximately 1,000rpm if the engine was started at tickover.



Green lamp for 'panel power on' should still function.

- 3) To stop the engine press the 'STOP' push button, hold in until engine stops. This button also switches the power off to the gauges, engine and power on lamp. Before investigating any specific electrical problem, always check:

- Connection between panel harness and panel loom. It must be clean, dry and secured with a cable tie.
- Check the start battery is connected to the correct terminal on the starter motor.
- Check the domestic battery is switched on and connected to the correct terminals for the 2nd alternator.
- Battery connections, inspecting condition of cables from battery to engine. If in doubt measure the voltage at the engine.
- If alternator charge problem, measure battery voltage with engine off and again with engine running, if there is an increase alternator is functioning correctly, if not refer to check list.

Electrical Fault Finding - All Lamp Panels

Problem	Possible Cause and Solution
No warning lamps or buzzer functioning, engine will not start or stop	<ul style="list-style-type: none"> • Battery isolation switch in off position - switch on • Starter battery discharged - charge • Engine fuse blown - check fuse (above starter motor or flywheel housing) and replace if necessary. • Check for wiring faults.
Non function of warning lamp. The water temperature lamp will not function unless engine is overheating or there is a wiring fault	<ul style="list-style-type: none"> • Disconnect switch wire to non-functioning lamp: green/blue –water temperature, white/brown –oil pressure, brown/yellow –alternator charge. Reconnect wire temporarily to another warning lamp that is functioning; if wire switches lamp on replace faulty lamp. • Disconnect positive feed to non-functioning lamp. Reconnect temporarily with wire from another warning lamp that is functioning, if wire switches lamp on rewire with new connection. • If none of the above, check continuity of connections from panel to engine.
Water temperature warning lamp on when engine is not over temperature (Not 2B or 2C deluxe panel see table on following page)	<p>If engine is cold:</p> <ul style="list-style-type: none"> • Faulty wiring, check connection and continuity (small green/blue) from switch to panel lamp. Ensure this connection is not shorting to earth (ground). • Faulty temperature switch –if lamp switches off on removal of connection to switch unit, replace. <p>If engine is warm:</p> <ul style="list-style-type: none"> • Switch wire connected to large sender terminal of switch/sender unit. Remove and refit to smaller (switch) terminal.
Buzzer not functioning. The buzzer will not sound for green 'power on' lamp	<ul style="list-style-type: none"> • If lamp is functioning but buzzer not sounding, check connection and continuity from illuminated warning lamp (red not green) to buzzer board. • Faulty warning panel buzzer board - replace.
Starter battery charge lamp not functioning	<p>If tachometer not functioning:</p> <ul style="list-style-type: none"> • Alternator not connected properly, check continuity of small brown wire from rear of alternator to 'AC' position on keyswitch. • Alternator connected properly, faulty alternator - replace <p>If tachometer functioning correctly:</p> <ul style="list-style-type: none"> • Check continuity of small brown/yellow wire from rear of alternator to no charge warning lamp on rear of panel. • If alternator connected properly, faulty panel warning lamp - replace
If tachometer not functioning	<ul style="list-style-type: none"> • Check connections on rear of tachometer, especially black/blue wire, terminal '4' • Check connection of black/blue wire on rear of 1st alternator (W connection, usually a bullet on flying lead, or lowest connection on alternators with 3 pin coupler) • Check continuity of black/blue wire from alternator to tachometer • Measure voltage from alternator W connection to earth (ground), should be approx. 7.5 - 9.0 volts AC
Domestic charge lamp not functioning, buzzer remains on with engine running	<ul style="list-style-type: none"> • Domestic battery not connected • Domestic battery not connected correctly: B+ to domestic isolation block on starboard rail (port on 75 - 95hp) B- to engine earth (ground) • Domestic battery flat • Panel relay faulty / incorrectly wired: Check voltage at relay terminal 86, white wire is positive feed for warning lamp from AC position of keyswitch.
Domestic charge lamp not functioning, buzzer switching off with engine running. This lamp will only function if a second alternator is fitted to the engine	<ul style="list-style-type: none"> • No second alternator fitted to engine, domestic lamp not used • D+ (charge indication) lamp connection at rear of alternator not connected • Two way plug and socket disconnected between engine harness and panel loom

Electrical Fault Finding - C Deluxe and Water Temperature Function on B Panels

In addition to the fault finding detailed on the previous table, the following is specific for the deluxe panel (Also applicable for the B panel with Murphy water temperature gauge)

Problem	Possible Cause and Solution
Oil pressure warning lamp not functioning, oil pressure gauge showing maximum deflection. Engine off and keyswitch in run position	<ul style="list-style-type: none"> Faulty wiring - check wire connection and continuity (small white/brown) from sender to panel lamp. Ensure this connection is not shorting to earth (ground).
Oil pressure gauge showing no movement - even when engine is started. Warning lamp functioning correctly	<ul style="list-style-type: none"> Faulty wiring - check oil pressure sender wire (small white/brown) is connected.
Oil pressure showing no movement, Warning lamp not functioning correctly	<ul style="list-style-type: none"> Check connection to oil pressure gauge, if plug is not connected to socket on rear of gauge, reconnect. If all connections are correctly made, possible faulty sender unit - check resistance to earth (ground) approx. 50 Ω . Replace if no reading or short-circuited. If adjusted correctly & buzzer still sounding, possible faulty switch gauge unit - replace.
Oil pressure showing normal operating pressure (0.75 - 5 bar). Buzzer sounding and lamp illuminated.	<p>Engine warm:</p> <ul style="list-style-type: none"> Incorrectly calibrated switching point for warning lamp, adjust on rear of gauge to 0.5 bar (minimum adjustment on gauge). If adjusted correctly & buzzer still sounding, faulty switch gauge unit - replace.
Water temperature gauge showing 120°C / 250°F. This also applies to the B Panel with Murphy gauge	<p>Engine cold / cool:</p> <ul style="list-style-type: none"> Faulty wiring, check water temperature sender wire is not shorting to earth (ground). Faulty sender unit, - check resistance to earth (ground), approx. 3.5k Ω (cold) – 0.5k Ω (warm). Replace if notably less.
Water temperature gauge showing normal operating temperature (85°C). Buzzer sounding and lamp illuminated. This also applies to the B Panel with Murphy gauge	<p>Engine warm:</p> <ul style="list-style-type: none"> Incorrectly calibrated switching point for warning lamp adjust on rear of gauge to 100°C / 210°F. If adjusted correctly & buzzer still sounding, faulty switch gauge unit – replace.
Water temperature gauge showing no movement, lamp not illuminated, engine warm. This also applies to the B Panel with Murphy gauge	<ul style="list-style-type: none"> Check connection to sender, if disconnected gauge will not function. Check connection to temperature gauge, if plug is not connected to socket on rear of gauge reconnect.
Water temperature gauge showing no movement, lamp not illuminated, engine warm. This also applies to the B Panel with Murphy gauge	<ul style="list-style-type: none"> Check connection to sender, if disconnected gauge will not function. Check connection to temperature gauge, if plug is not connected to socket on rear of gauge reconnect. If all connections are correctly made, faulty sender unit - check resistance to earth (ground), approx. 3.5k Ω (cold) – 0.5k Ω (warm). Replace if no reading.

Electrical Fault Finding – Non-Beta Panels

Engines can be supplied wired up to suit VDO switch senders, usually fitted to a non-Beta control panel. If so refer to our wiring diagram 200-60971/01 (also part number for replacement harness)

- Loom is configured differently in the 11-way plug to accommodate the extra wiring.
- Small brown wire (battery sensed alternator feed) fitted with bullet connection beside harness plug.
- Oil pressure and water temperature switch / senders fitted to engine, requiring individual connections for driving gauges and warning lamps.

Note: Water temperature switch/sender (Part number 200-01133)

Large spade is sender connection	(green/blue)
----------------------------------	--------------

Small spade is switch connection	(blue/yellow)
----------------------------------	---------------

Oil pressure switch/sender (Part number 200-62680)

G	Gauge wire	(white/brown)
---	------------	---------------

M	Earth (ground)	(black)
---	----------------	---------

WK	Warning lamp	(green/yellow)
----	--------------	----------------

Electrical Fault Finding – Extension Harnesses

Some installations require one of the panel extensions 11 way connectors to be removed to allow the cable to be passed through bulkheads etc.

If any panel problems are experienced, after this may have been carried out, visually check all 11 way connections on engine harness to panel extension (**and panel extension to panel on C 'Deluxe'**) to ensure wire colours to each terminal match up to the correct colour in its corresponding terminal.

Extra attention must be given to black (ground) and black/blue (tacho), also brown (switched positive to alternator) and brown/yellow (charge fail) as these connections are harder to distinguish between in poorly lit areas. Whilst doing this check integrity of each connection to ensure terminals have not become damaged. Once checked, re-fit cable tie around each connection to keep them secure.

Electrical Fault Finding – Insulated earth

If your application is wired as insulated earth return and the engine will not operate correctly, always check starter battery negative is connected to the correct terminal on the isolating solenoid.

It should be connected to the terminal which is also used for all the small black wires, **NOT the terminal with the single black wire connected directly to engine ground.**

Spanner Torque Settings

Tightening Torques for general use bolts and nuts

ITEM	Size x Pitch	kgf m	lbf ft (ft lbs)	N m
M6 (7T) : 6mm (0.24in)	-	9.8~11.3	1.0~1.15	7.2~8.3
M8 (7T) : 8mm (0.31)	-	23.5~27.5	2.4~2.8	17.4~20.3
M10 (7T) : 10mm (0.39in)	-	49.0~55.9	5.0~5.7	36.2~41.2
M12 (7T) : 12mm (0.47in)	-	77.5~90.5	7.9~9.2	57.1~66.5

Tightening Torques for special use bolts and nuts

Head Bolts	M12 x 1.25	98.1~107.9	10~11	72.3~79.6
Bolts, Connecting Bolts	M10 x 1.25	78.5~83.4	8.0~8.5	57.8~61.5
Bolts, Flywheel	M12 x 1.25	98.1~107.9	10~11	72.3~79.6
Bolts, Bearing Case	M14 x 1.5	137.7~147.2	14~15	101.2~108.5
Bolts, Crankshaft	M16 x 1.5	343.4~372.8	35~38	253.1~274.7
Bolts, Rocker Arm	M10 x 1.25	49.0~61.8	5.0~5.7	36.2~41.2
Glow Plugs (Beta 75)	M10 x 1.25	19.6~24.5	2.0~2.5	14.5~18.1
Oil Switch	R 1/8	14.7~19.6	1.5~2.0	10.8~14.5
Nozzle, Holder Assembly	M20 x 1.5	49.0~68.6	5.0~7.0	36.2~50.6
Nuts, Overflow Pipe	M12 x 1.5	19.6~24.5	2.0~2.5	14.5~18.1
Nuts, Injection Pipe	M12 x 1.5	22.6~36.3	2.3~3.7	16.6~26.8
Nut, Injection Pump	M14 x 1.5	73.5~83.4	7.5~8.5	54.2~61.5

Index - Wiring Diagrams and General Arrangements

1. Typical starter motor ratings		Page 10
2. Suggested engine starter battery size		Page 10
3. Keyswitch terminations		Page 10
4. Standard engine harness	200-08808	Page xx
5. Standard engine harness H/E (100 Amp)	200-06015	Page xx
6. Standard engine harness K/C	200-05442	Page xx
7. Diagram of 2a panel & cut-out	200-06516	Page xx & xx
8. Diagram of 2ab'd' panel & cut-out	200-06517	Page xx & xx
9. Diagram of 2ab'V' panel & cut-out	200-06519	Page xx & xx
10. Diagram of 2ab'V'W panel & cut-out	200-06333	Page xx & xx
11. Diagram of 2b panel & cut-out	200-06520	Page xx & xx
12. Diagram of 2c'd' deluxe panel & cut-out	200-06518	Page xx & xx
13. Diagram of domestic extension harness	200-04588	Page xx
14. Diagram of domestic charge sub loom (K/C)	200-01197	Page xx
15. GA of BF2803 K/C –PRM260	100-05714	Page xx
16. GA of BF2803 H/E –ZF25H	100-01423	Page xx
17. GA of BV33/3800 K/C –PRM260	100-06201	Page xx
18. GA of BV33/3800 H/E –PRM260	100-06202	Page xx
19. Split charge relay wiring (machine sensed alt.)	300-62210	Page xx
21. Starter booster relay diagram	300-58520	Page xx
22. 100 Amp alternator information (H/E only)	200-05466	Page xx
23. Beta Controller information (H/E only)		Page xx
24. Wiring 100 Amp & Controller (H/E only)	100-05470	Page xx
25. Declaration of Conformity for Recreational Craft		Page 61
26. Emission durability		Page 62
27. Quick reference parts list		Page 63 & 64
28. Maintenance record and service items		Inside back cover

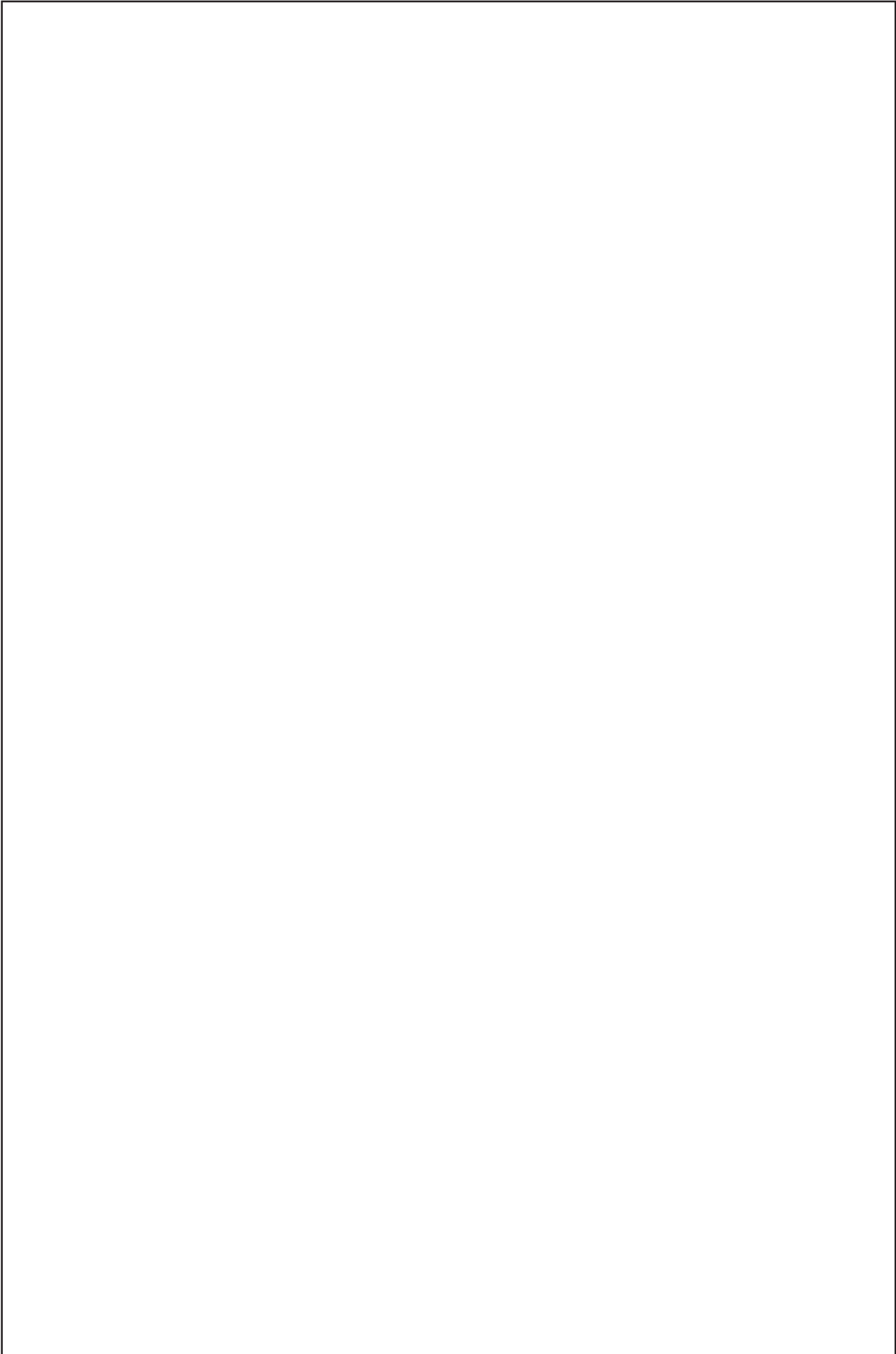

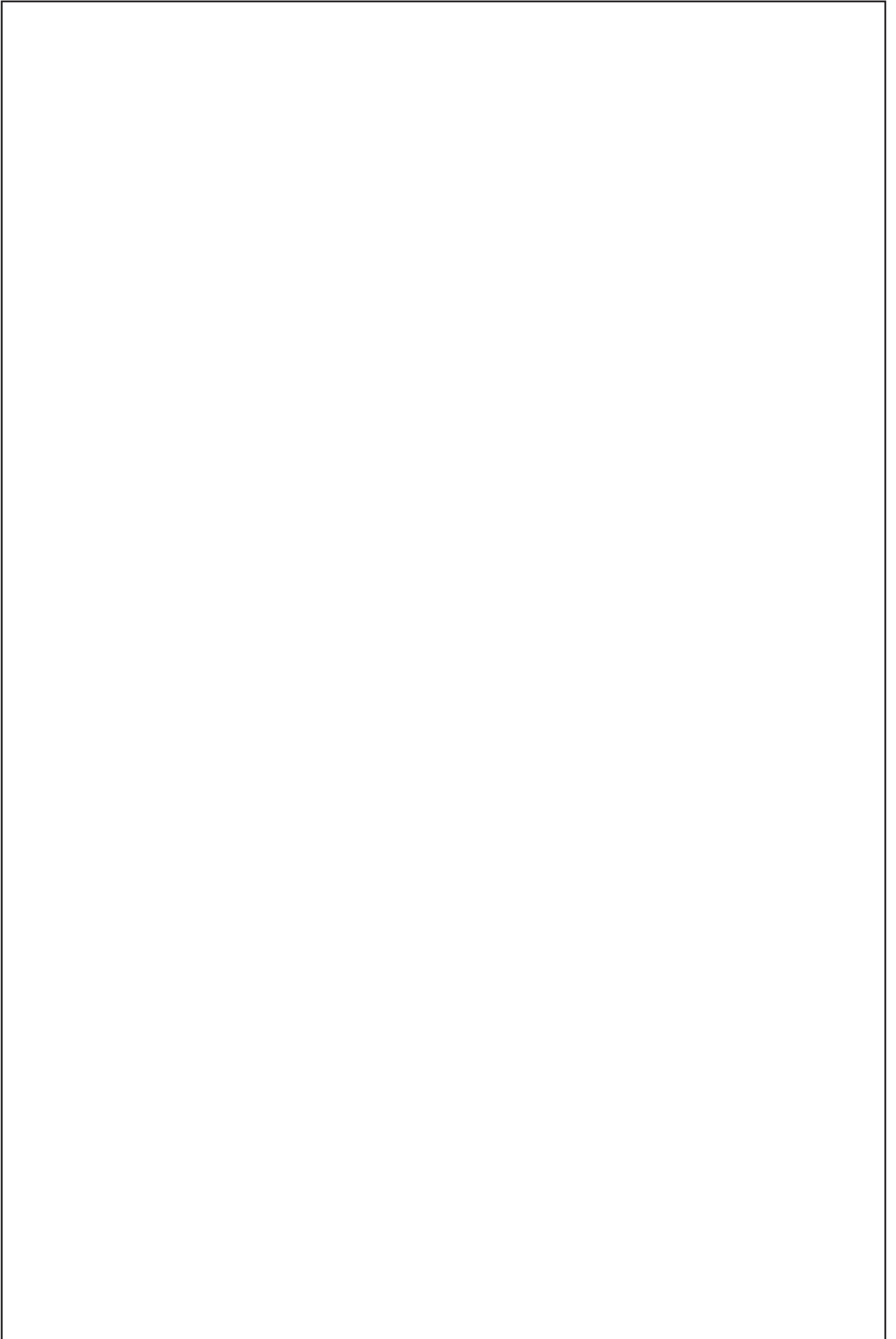

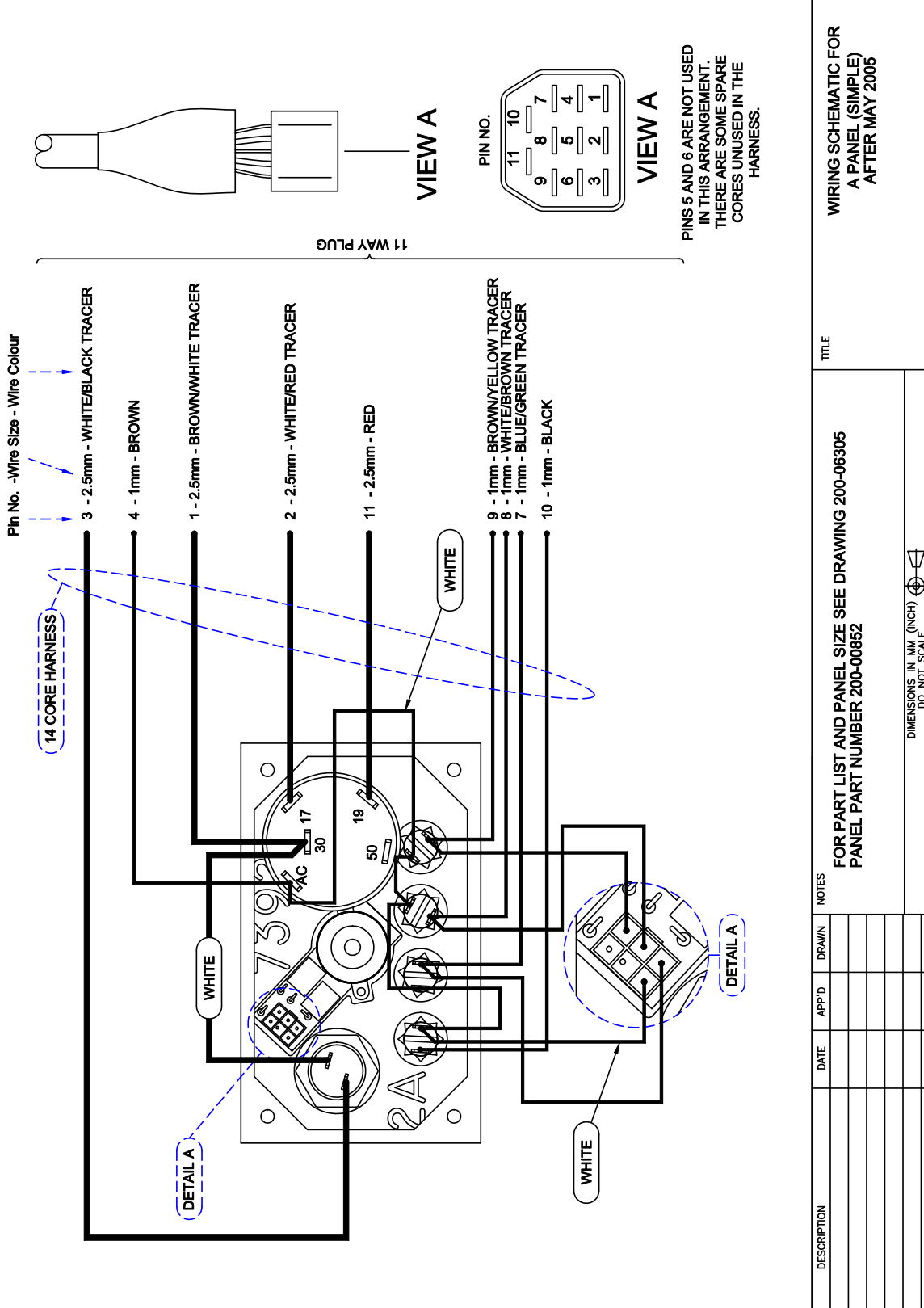

REV	DESCRIPTION	DATE	APPD	DRAWN	NOTES	TITLE	SCALE	DWG NO.	REV
						FOR PART LIST AND PANEL SIZE SEE DRAWING 200-06305 PANEL PART NUMBER 200-00852	A4	200-06516	
							DM	N/A	
							DM	1 of 1	15/05/05
						DIMENSIONS IN MM (INCH) DO NOT SCALE			
						BETA MARINE LTD. WYNNWELLS WATERWELLS QUEDSBURY, GLOUCESTER, GL2 2AD, U.K. TEL: (01453) 835282 FAX: (01453) 835284			
						BETA MARINE			
						DRAWN BY:- TW CHECKED BY:- DM			
						WIRING SCHEMATIC FOR A PANEL (SIMPLE) AFTER MAY 2005			

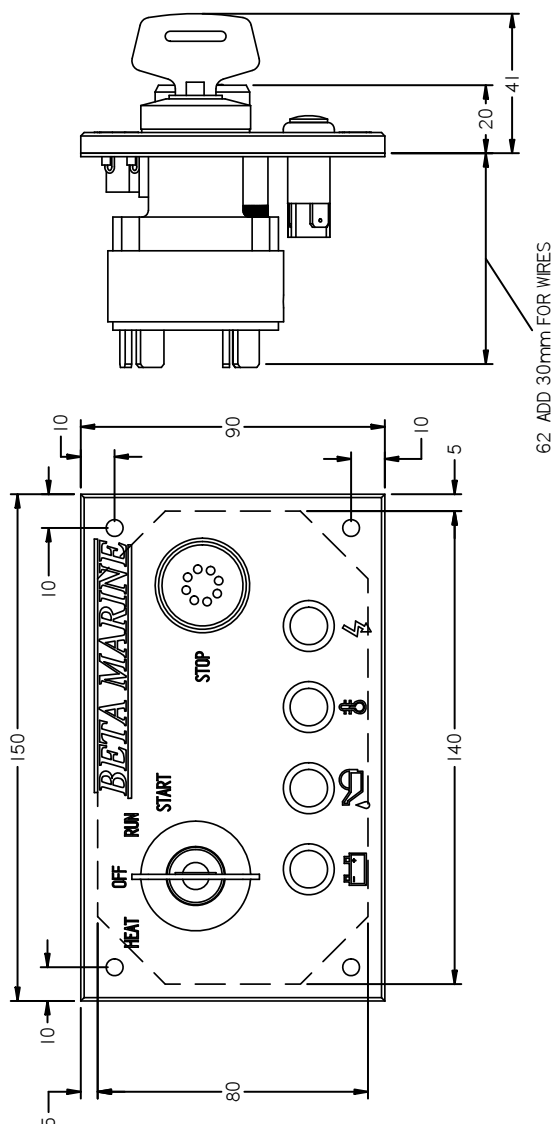

REV/	DESCRIPTION	DATE	APPD	DRAWN	NOTES	TITLE
01	CHANGED KEY SWITCH	05/09/08	LT	TW		A PANEL
<small>DIMENSIONS IN MM (INCH) DO NOT SCALE</small>						
<small>BETA MARINE LTD, DAVY WAY, WATERWELLS, QUEDSELEY, GLOUCESTER, GL2 2AD, U.K. TEL: (01453) 835282 FAX: (01453) 835284</small>						
				SIZE	DWG NO.	REV
				A4	200-06305	01
				DRAWN BY:-	CHECKED BY:-	DATE
				TW	LT	05/09/2008
				SCALE	PAGE	
				NTS	2 of 2	

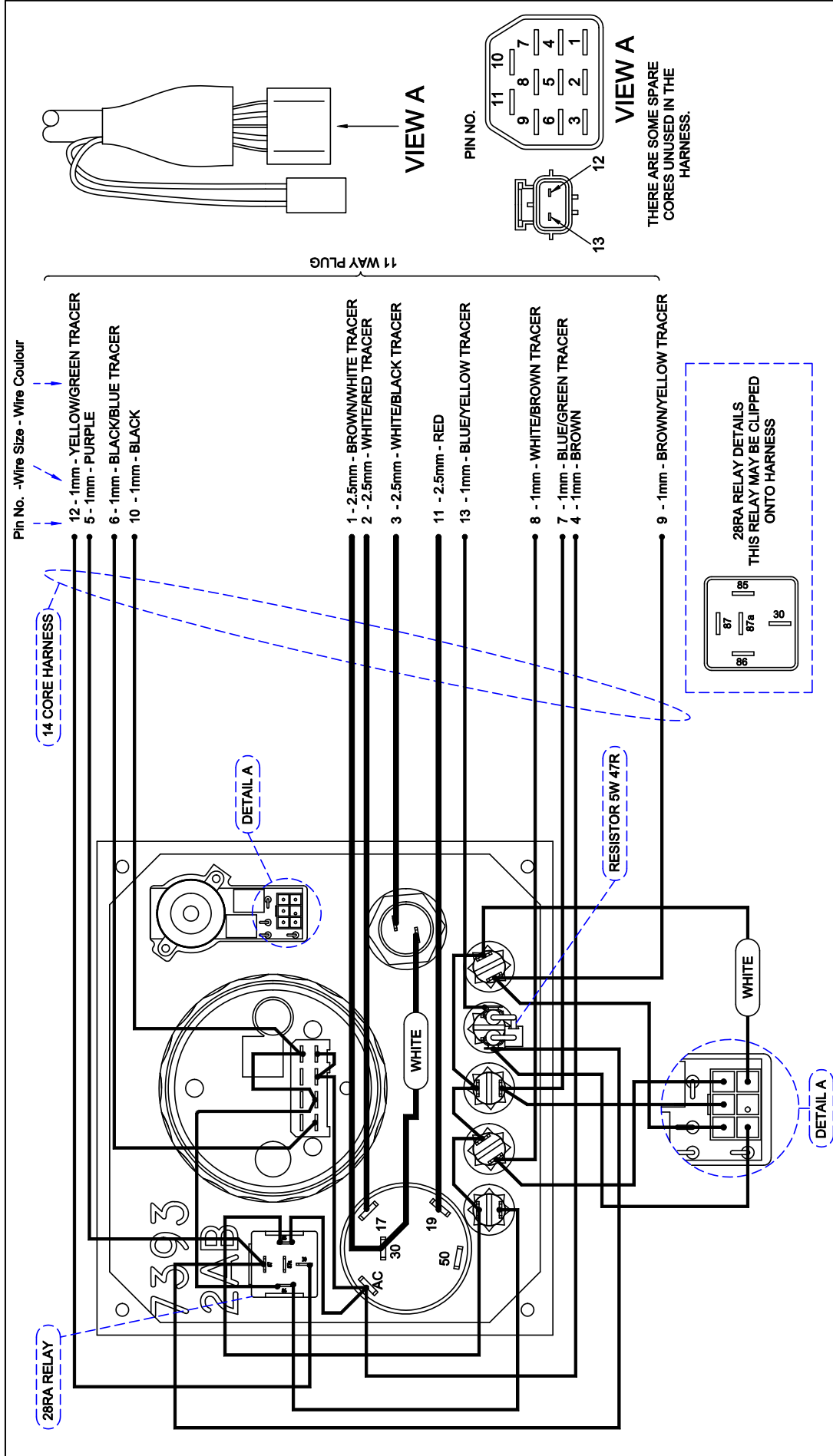

REV	DESCRIPTION	DATE	APP'D	DRAWN	NOTES	TITLE	SCALE	N/A	PAGE	1 of 1	DATE	15/05/05	REV
.						FOR PART LIST AND PANEL SIZE SEE DRAWING 200-06304 PANEL PART NUMBER 200-00850 (THIS EXCLUDES TACHO)	DM	N/A					
						WIRING SCHEMATIC FOR AB PANEL AFTER MAY 2005	A4	DM					
						DRAWN BY: TW	SIZE DWG NO. A4	SCALE	N/A	PAGE	1 of 1	DATE	REV
						BETA MARINE LTD, DAVY WAY, WATERWELLS, QUEDGELEY, GLoucester, GL2 2AD, UK							
						BETA MARINE							
						TEL: (01453) 835282							
						FAX: (01453) 835284							
						DIMENSIONS IN MM (INCH) DO NOT SCALE							

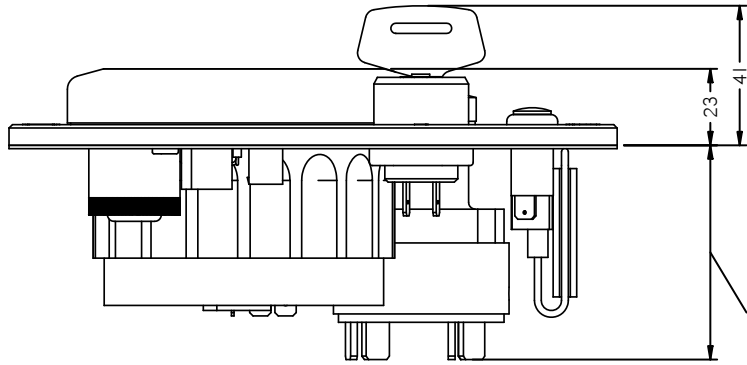
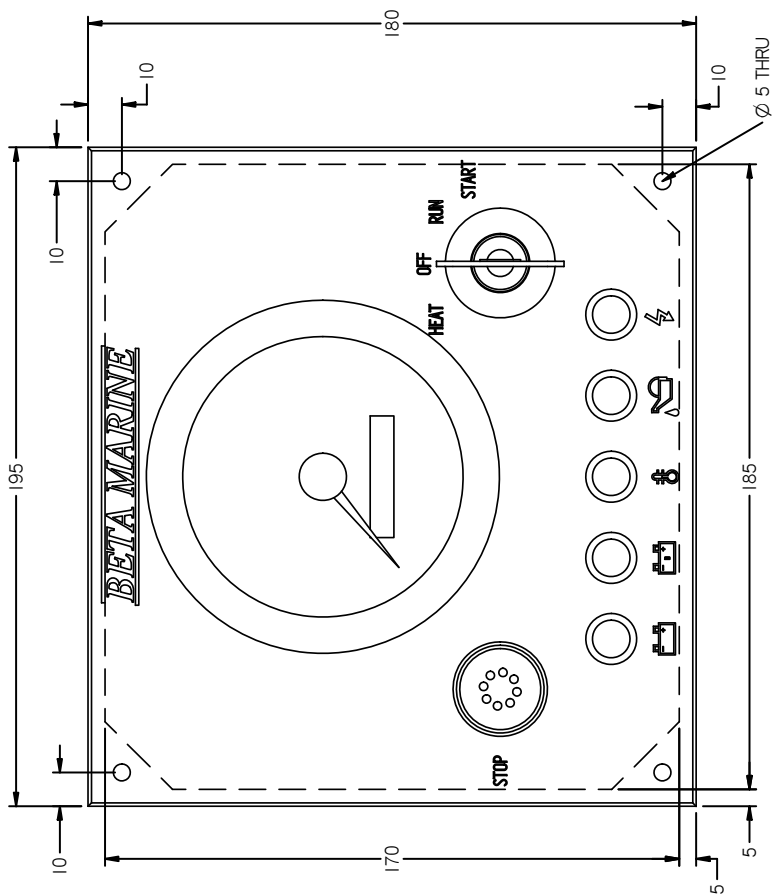

63 ADD 30mm FOR WIRES

REV		DESCRIPTION	DATE	APPD	DRAWN	NOTES	TITLE			
01		CHANGED KEY SWITCH	05/09/08	LT	TW		AB PANEL			
							DRAWN BY:-	SIZE	DWG NO.	REV
							TW	A4	200-06304	01
							CHECKED BY:-	SCALE	PAGE	DATE
							LT	NTS	2 of 2	06/10/2007
							DIMENSIONS IN MM (INCH) DO NOT SCALE			
							BETA MARINE LTD, DAVY WAY, WATERWELLS, QUEDGELEY, GLOUCESTER, GL2 2AD, U.K.			
							BETA MARINE TEL: (01463) 835282 FAX: (01463) 835284			

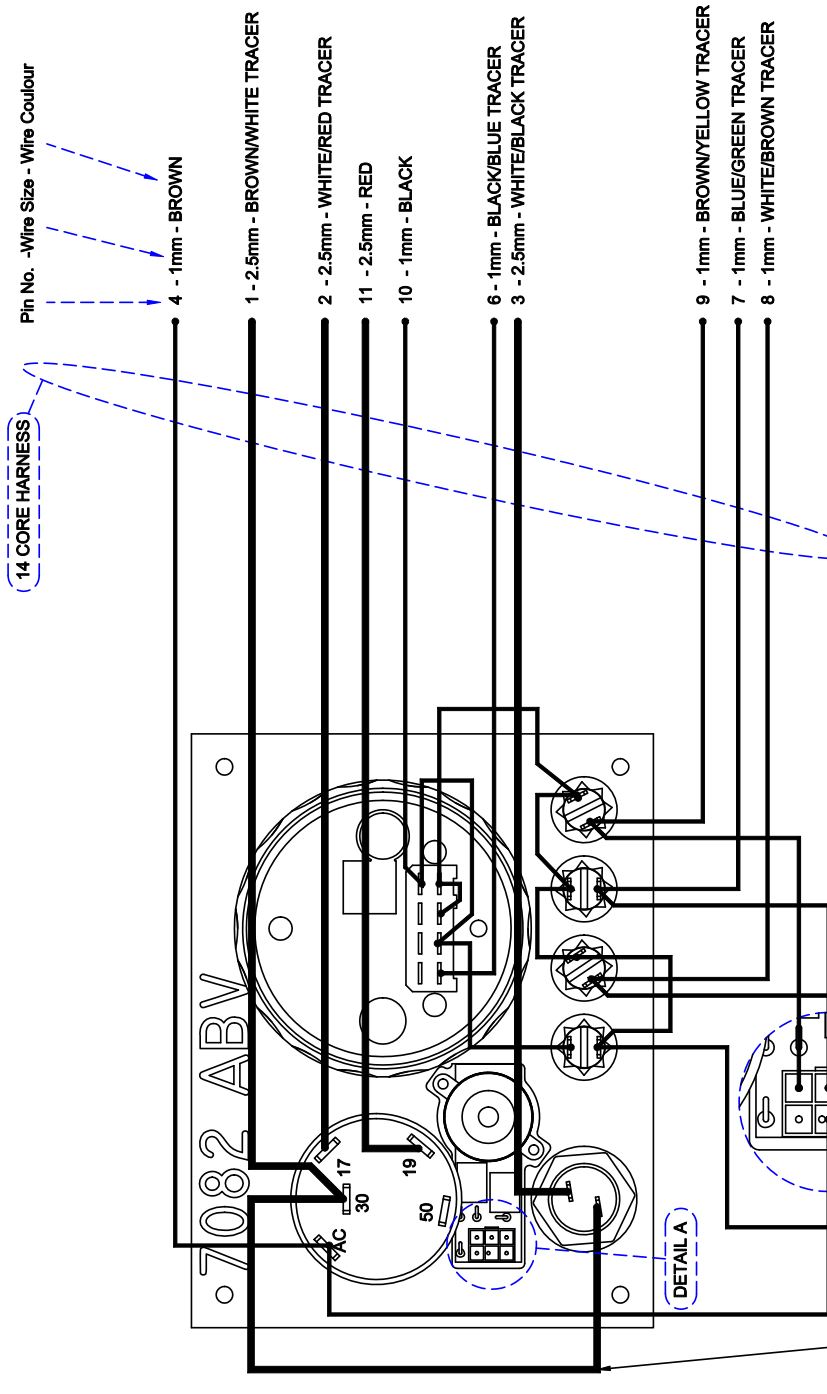

REV	DESCRIPTION	DATE	APP'D	DRAWN	NOTES	TITLE	SCALE	N/A	PAGE	1 of 1	DATE	16/05/05
.					FOR PART LIST AND PANEL SIZE SEE DRAWING 200-06320 PANEL PART NUMBER 200-89421 THIS EXCLUDES TACHO	WIRING SCHEMATIC FOR ABV PANEL AFTER MAY 2005	A4	N/A	1	1		
							TW					
							DRAWN BY:-					
							CHECKED BY:-					
							DIMENSIONS IN MM (INCH) DO NOT SCALE					
							BETA MARINE LTD, DAVY WAY, WATERWELLS, QUEDGBELLY, GLOUCESTER, GL2 2AD, U.K.					
							BETA MARINE TEL: (01453) 835282 FAX: (01453) 835284					
							SIZE	DWG NO.				
							A4	200-06519				
							SCALE	N/A				
							REV					

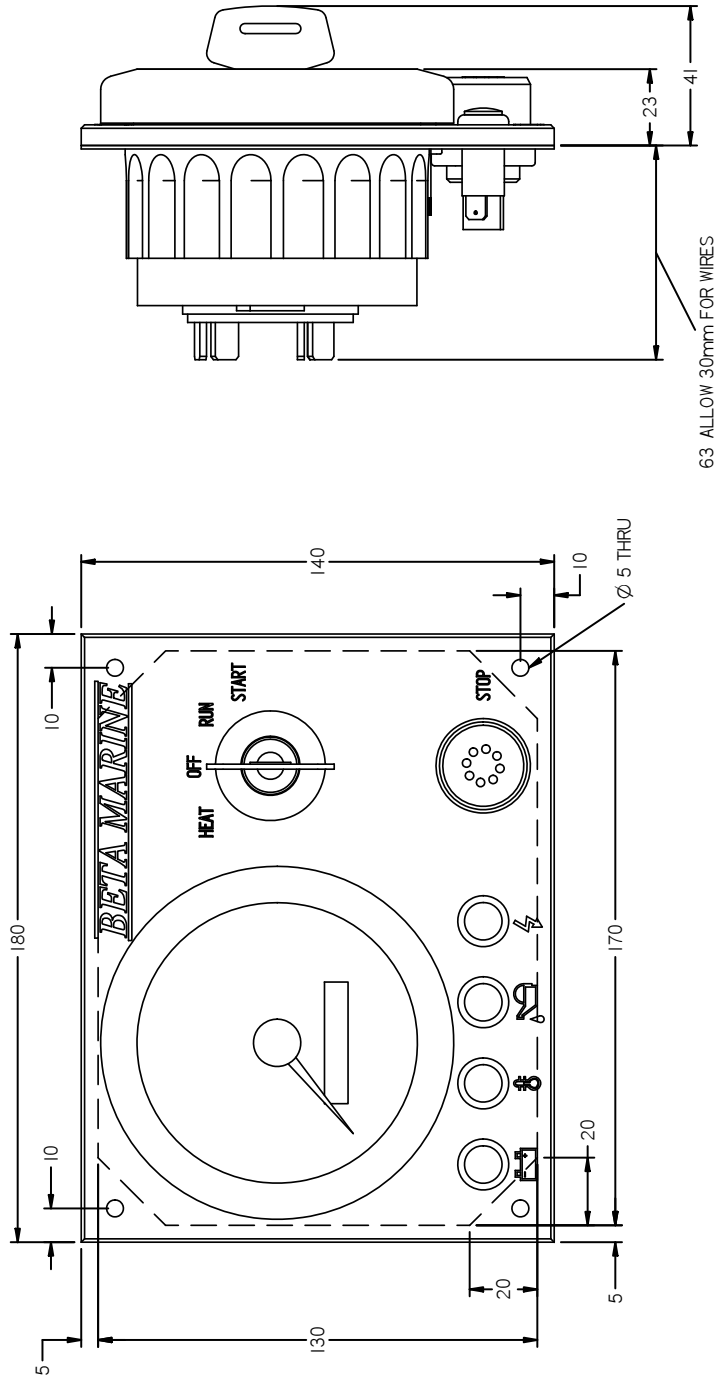

ABV PANEL

TITLE

NOTES

REV	DESCRIPTION	DATE	APPD	DRAWN	NOTES
01	CHANGED KEY SWITCH	05/09/08	LT	TW	

DIMENSIONS IN MM (INCH)
DO NOT SCALE

BETA MARINE

BETA MARINE LTD,
DAVY WAY,
WATERWELLS,
QUEDESELEY, GLOUCESTER,
GL2 2AD, U.K.

TEL: (01463) 835282 FAX: (01463) 835284

DRAWN BY: LT/TW
CHECKED BY: LT

SCALE: NTS
PAGE: 2 of 2

DWG NO: 200-06320/01
REV: 00

DATE: 06/10/2007

VIEW LOOKING ON CONNECTOR FACE
FITTED WITH MALE SPADE/BULLET

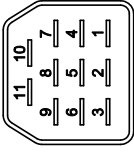

- 1 - 2.5mm BROWN/WHITE TRACER
- 2 - 2.5mm WHITE/RED TRACER
- 3 - 2.5mm WHITE/BLACK TRACER
- 4 - 1mm BROWN
- 5 - 1mm PURPLE
- 6 - 1mm BLACK/BLUE TRACER
- 7 - 1mm BLUE/GREEN TRACER
- 8 - 1mm WHITE/BROWN TRACER
- 9 - 1mm BROWN/YELLOW TRACER
- 10 - 1mm BLACK
- 11 - 2.5mm RED

11 WAY PLUG
SOCKET PINS

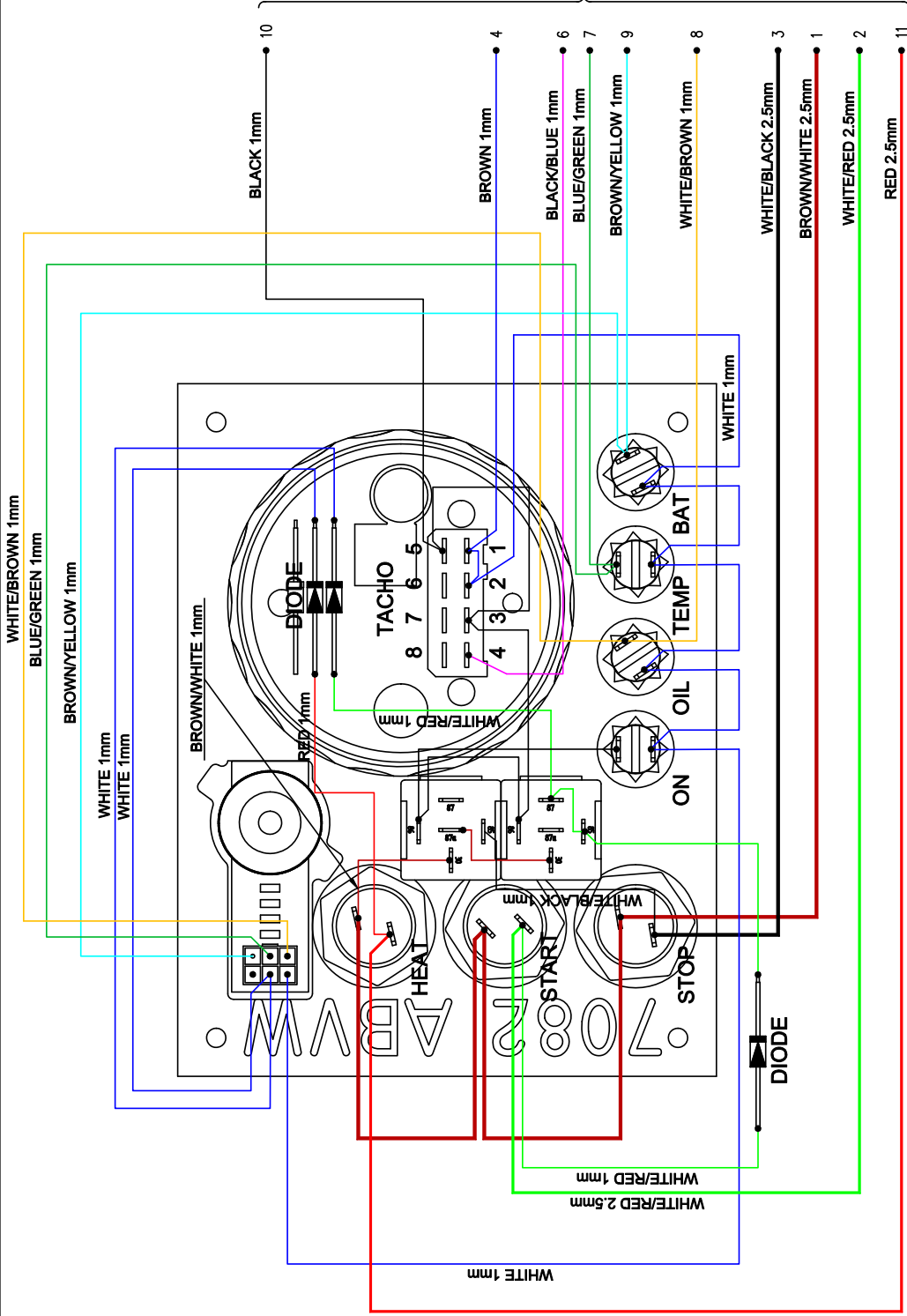
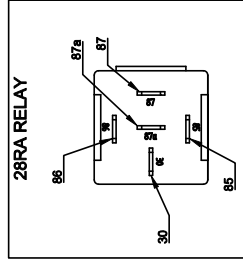

REV	DESCRIPTION	DATE	APP'D	DRAWN	NOTES	TITLE	SCALE	PAGE	DATE	REV
01	WIRE COLOURS	15/10/04	DM	TW		WIRING SCHEMATIC FOR ABVV PANEL	N/A	1 of 1	03/12/04	02
02	MOVED BROWN/YELLOW WIRE	20/01/08	DM	TW						

DRAWN BY: TW		SIZE A4	DWG NO. 100-06333	REV 02
CHECKED BY: DM		SCALE N/A	PAGE 1 of 1	DATE 03/12/04

DIMENSIONS IN MM (INCH)
DO NOT SCALE

BETA MARINE

BETA MARINE LTD,
DAY WAY,
WATERWELLS,
QUEDSBELLY,
GLOUCESTER, GL2 2AD, UK
TEL: (01453) 835282 FAX: (01453) 835284

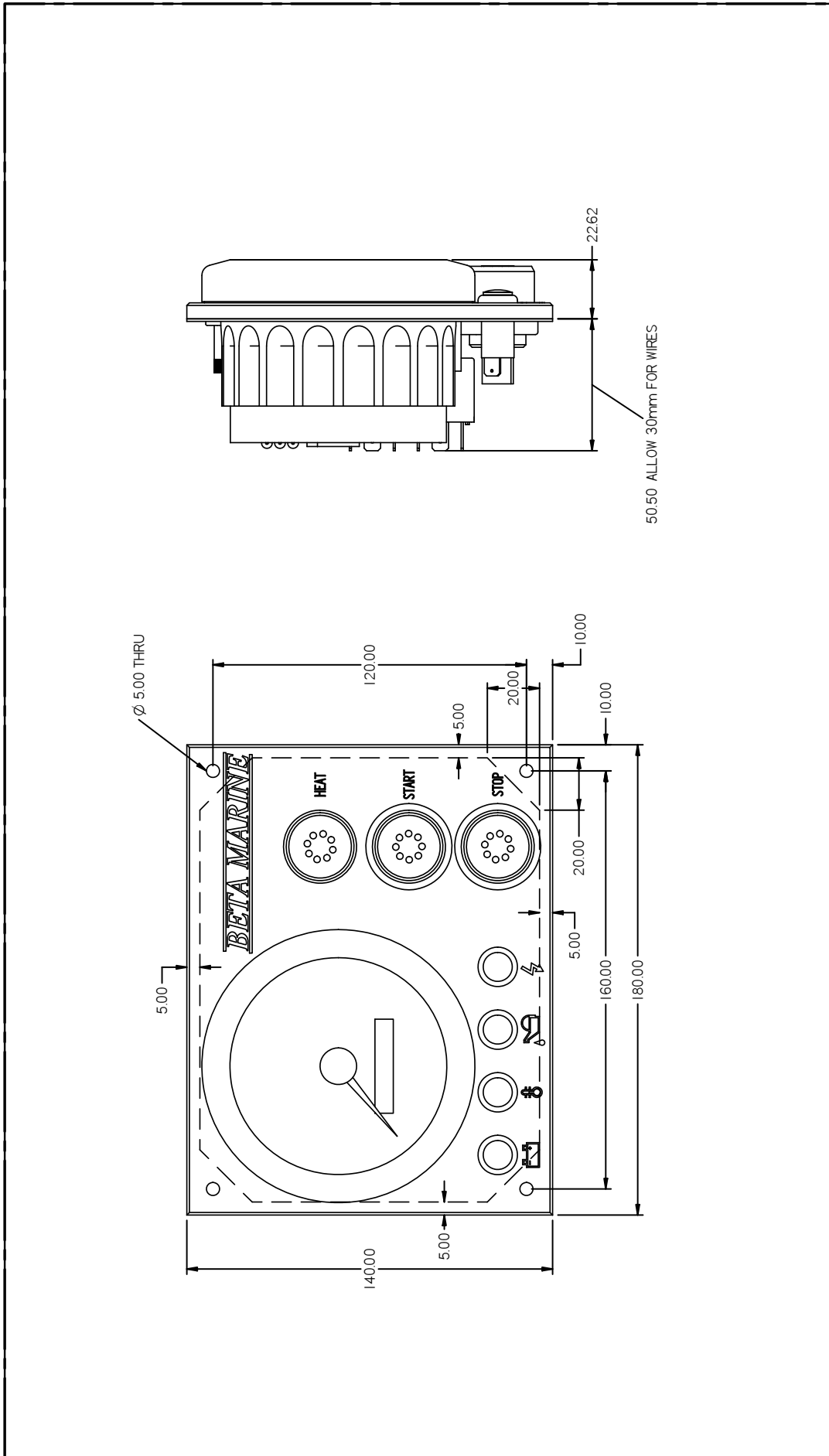

REV	DESCRIPTION	DATE	APPD	DRAWN	NOTES	TITLE	SCALE	PAGE	DATE
01					AS USED ON K14744	ABW SPLASH PROOF PANEL	LT	2 of 2	05/10/2007

DRAWN BY:-	TW	SIZE	A4	DWG NO.	200-06331	REV	00
CHECKED BY:-	LT	SCALE	NTS	PAGE	2 of 2	DATE	05/10/2007

DIMENSIONS IN MM (INCH)
 DO NOT SCALE

BETA MARINE

BETA MARINE LTD,
 MERRETT'S MILLS,
 BATH ROAD,
 SOUTH WOODCHESTER,
 STROUD, GLOS. GL9 8EU
 TEL: (01453) 836282 FAX: (01453) 836284

Pin No. - Wire Size - Wire Colour

- 7 - 1mm - BLUE/GREEN TRACER
- 4 - 1mm - BROWN
- 1 - 2.5mm - BROWN/WHITE TRACER
- 2 - 2.5mm - WHITE/RED TRACER
- 11 - 2.5mm - RED
- 10 - 1mm - BLACK
- 6 - 1mm - BLACK/BLUE TRACER
- 9 - 1mm - BROWN/YELLOW TRACER
- 8 - 1mm - WHITE/BROWN TRACER
- 3 - 2.5mm - WHITE/BLACK TRACER

14 CORE HARNESS

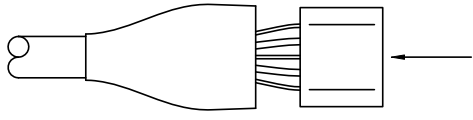

VIEW A

PIN NO.

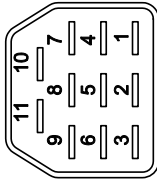

VIEW A

PIN 5 IS NOT USED IN THIS ARRANGEMENT. THERE ARE SOME SPARE CORES UNUSED IN THE HARNESS.

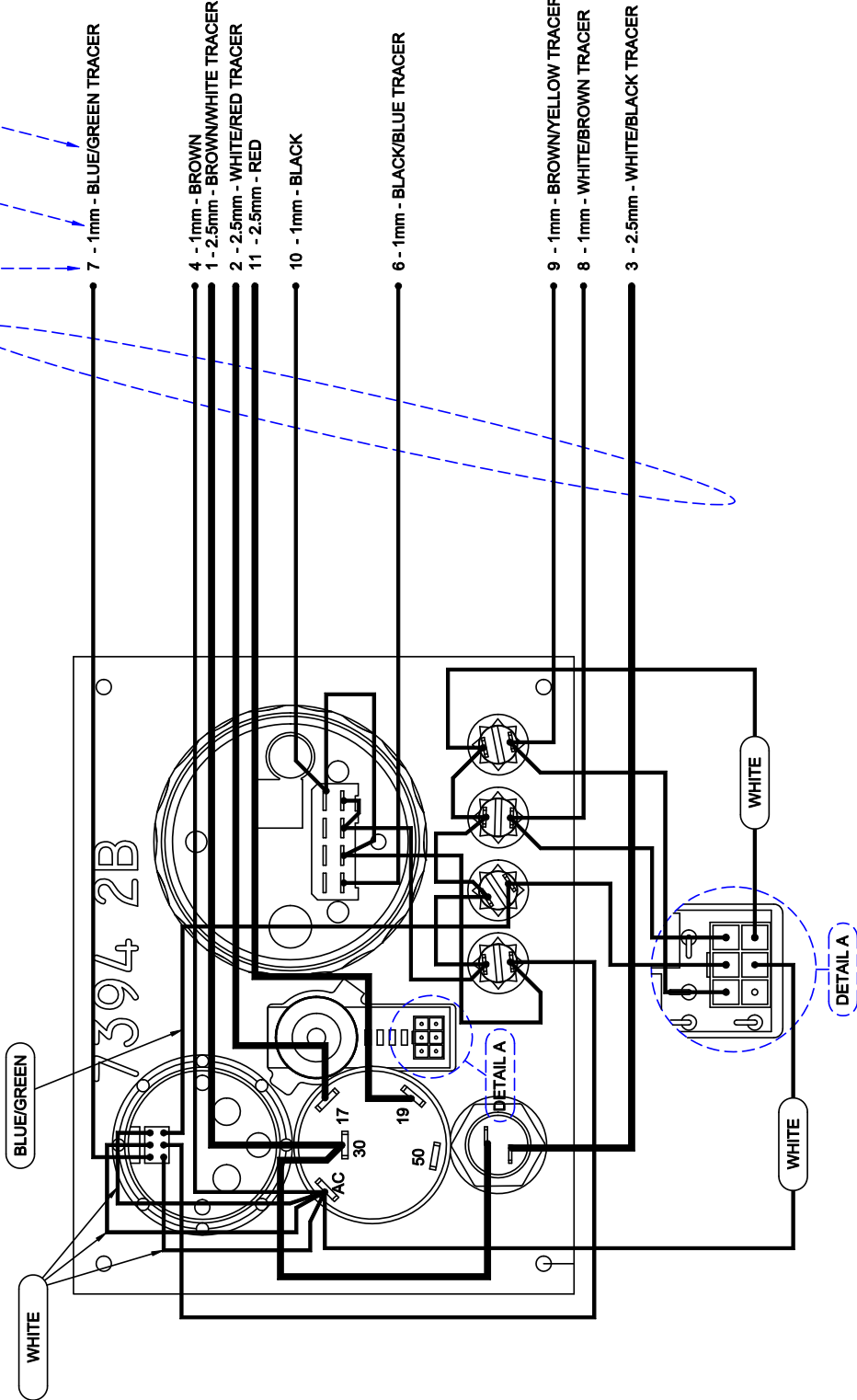

11 WAY PLUG

REV	DESCRIPTION	DATE	APP'D	DRAWN	NOTES	TITLE	SCALE	N/A	PAGE	1 of 1	DATE	16/05/05
						WIRING SCHEMATIC FOR B PANEL AFTER MAY 2005						
						FOR PART LIST AND PANEL SIZE SEE DRAWING 200-06303 PANEL PART NUMBER 200-05408 (THIS EXCLUDES TACHO & TEMPERATURE GAUGE)						
						DIMENSIONS IN MM (INCH) DO NOT SCALE						
						BETA MARINE LTD, DAVY WAY, WATERWELLS, QUIDDELEY, GLOUCESTER GL2 2AD, UK						
						BETA MARINE						
						TEL: (01453) 835282 FAX: (01453) 835284						
						DRAWN BY:- TW	SIZE A4					
						CHECKED BY:- DM	SCALE	N/A	PAGE	1 of 1	DATE	16/05/05
						REV						
						DWG NO.						
						200-06520						

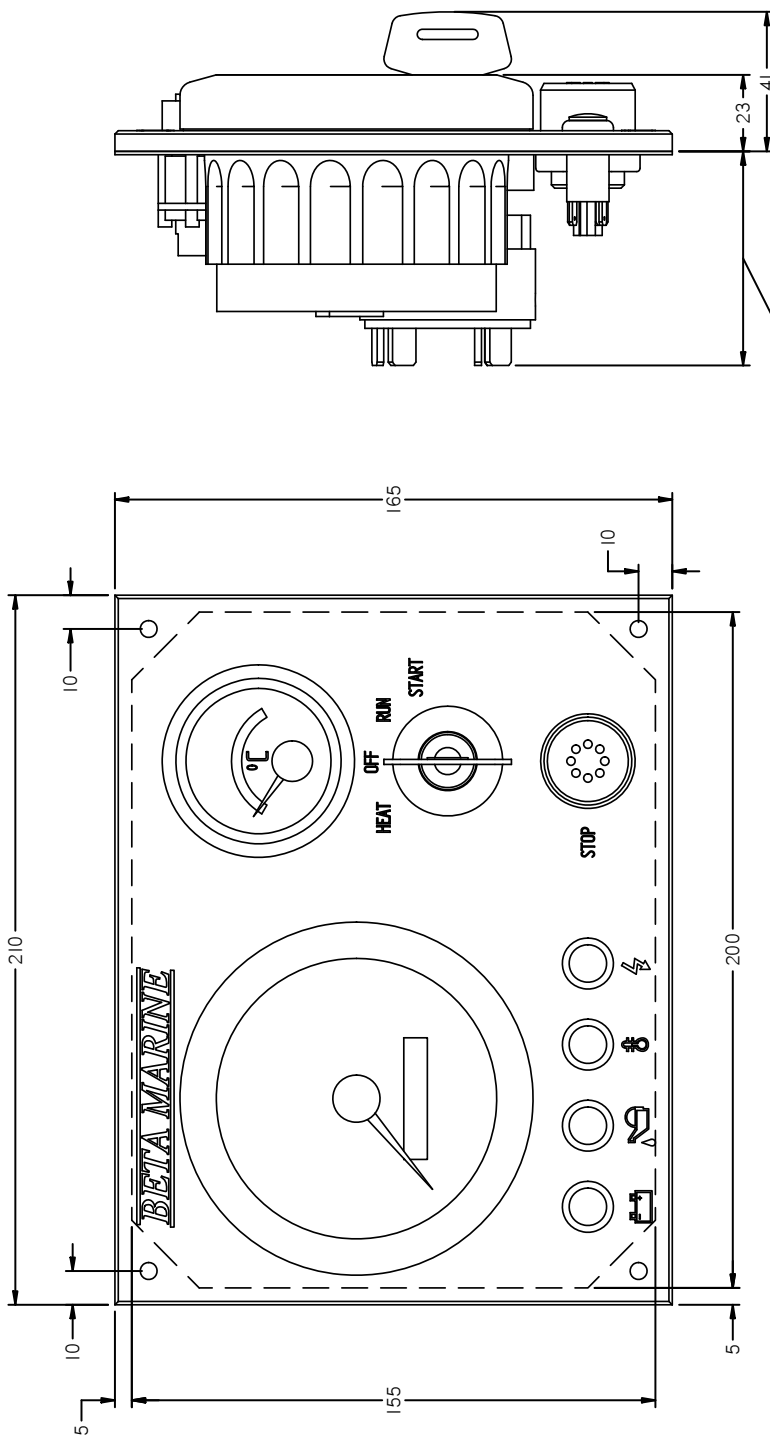

63 ALLOW 30mm FOR WIRES

REV	DESCRIPTION	DATE	APP'D	DRAWN	NOTES	TITLE
01	CHANGED KEY SWITCH	05/09/08	LT	TW		B PANEL
						<small>DIMENSIONS IN MM (INCH) DO NOT SCALE</small>
						<small>DRAWN BY:-</small> TW <small>CHECKED BY:-</small> LT
						<small>SCALE</small> NTS <small>PAGE</small> 2 of 2 <small>REV</small> 01 <small>DATE</small> 06/10/2007
						<small>BETA MARINE LTD, WATFOLLS, QUEDDELEY, GLOUCESTER, GL2 2AD, U.K.</small> BETA MARINE <small>TEL: (01453) 836282 FAX: (01453) 836284</small>

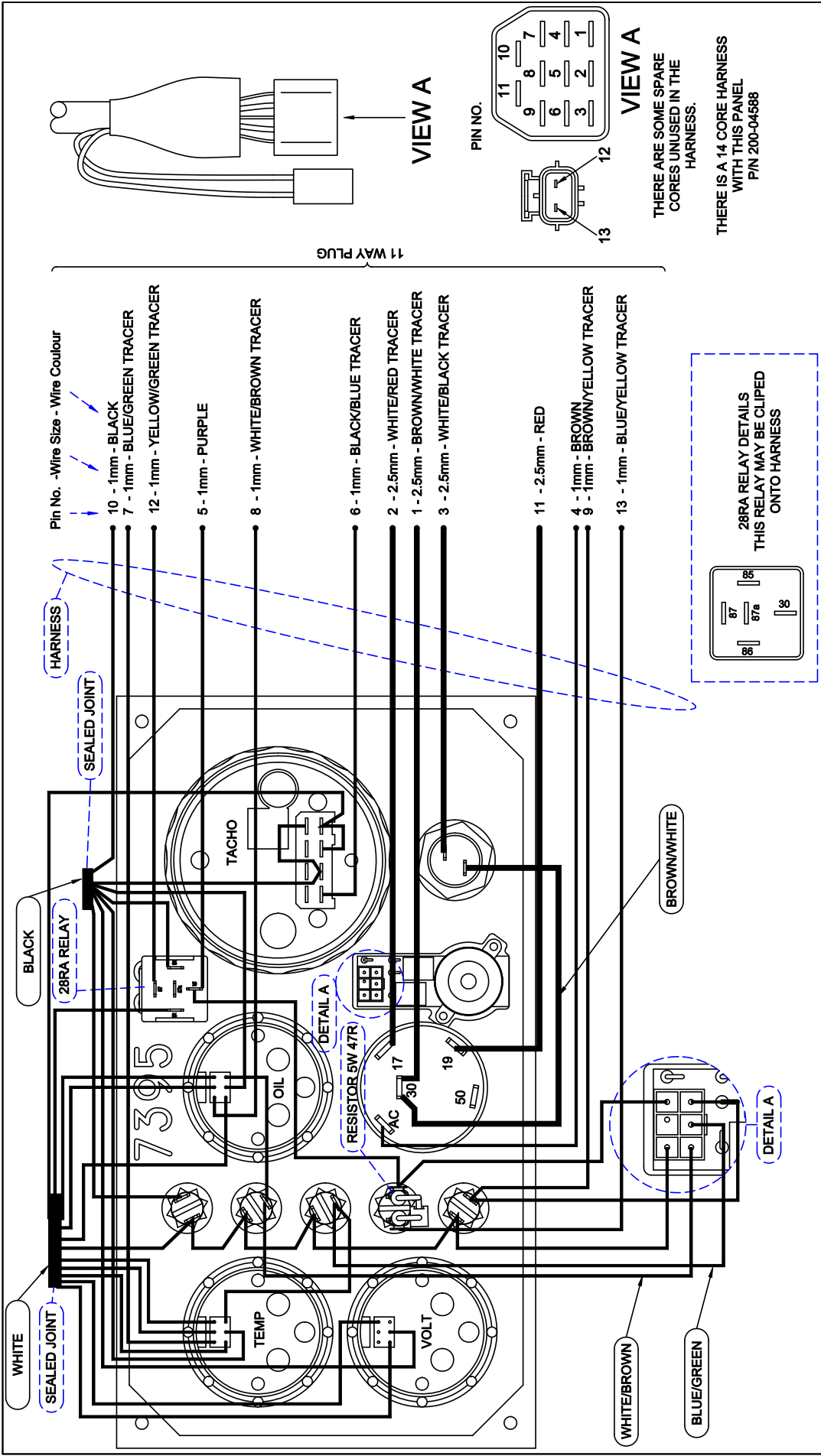

REV	DESCRIPTION	DATE	APPD	DRAWN	NOTES	TITLE	SCALE	PAGE	DATE	REV
01	CHANGED WHITE & BLACK AROUND	19/06/05	DM	TW	FOR PART LIST AND PANEL SIZE SEE DRAWING 200-06306 PANEL PART NUMBER 200-06445 (THIS EXCLUDES GAUGES)	WIRING SCHEMATIC FOR C PANEL (DELUXE) AFTER MAY 2005	N/A	1 of 1	15/05/05	01
							DRAWN BY:- TW		DWC NO. 200-06518	
							CHECKED BY:- DM		SCALE N/A	
DIMENSIONS IN MM (INCH) DO NOT SCALE BETA MARINE BETA MARINE LTD, MERRETT'S MILLS, BATH ROAD, SOUTH WOODCHESTER, STROUD, GLOS. GL5 3EU TEL: (01453) 835282 FAX: (01453) 835284										

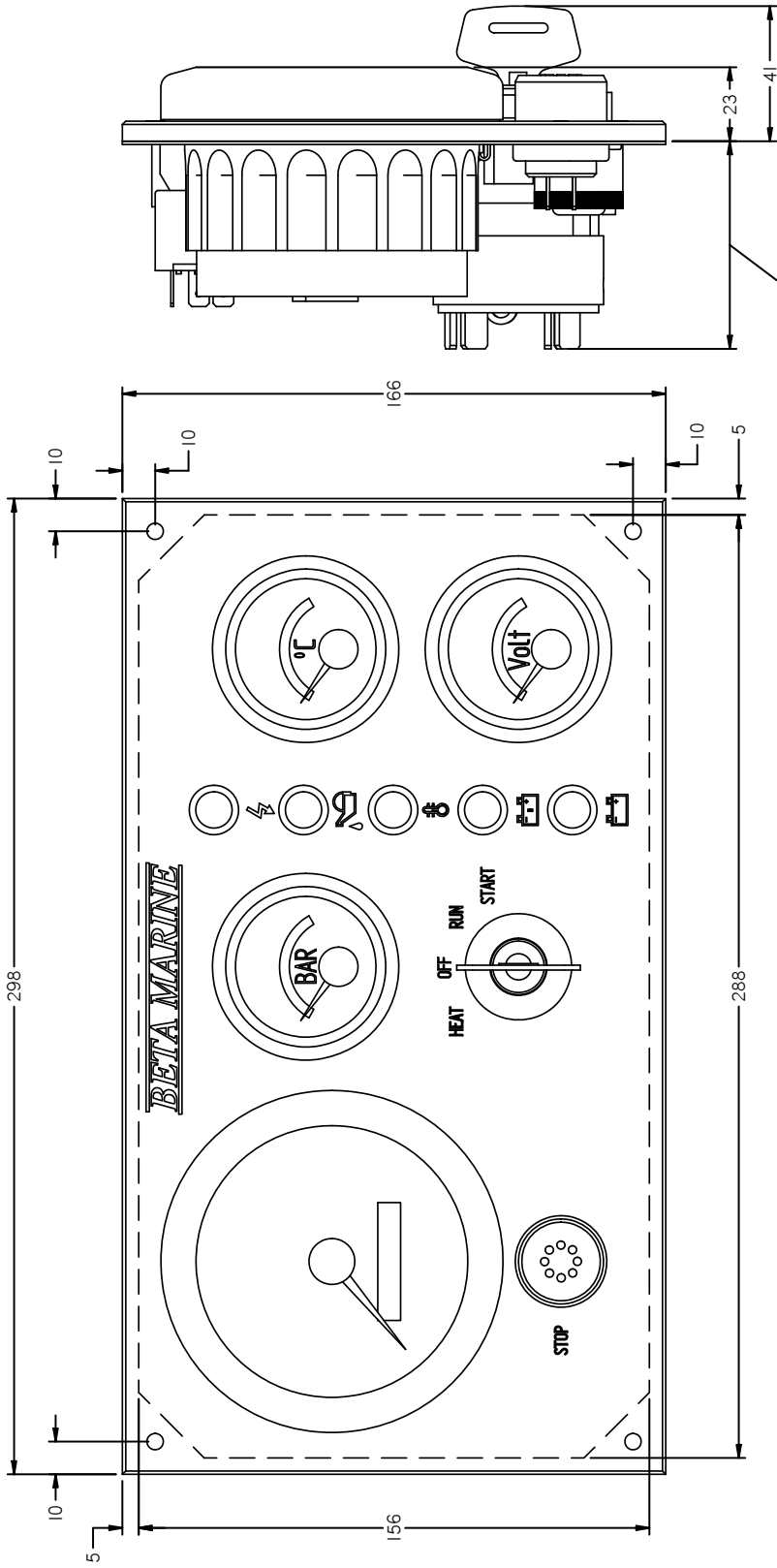

REV		DESCRIPTION	DATE	APP'D	DRAWN	NOTES	TITLE			
01		CHANGED KEY SWITCH	05/09/08	LT	TW		C PANEL			
							DRAWN BY:-	TW		
							CHECKED BY:-	LT		
							DWG NO.	200-06306	REV	01
							SIZE	A4	SCALE	2 of 2
							DATE	05/10/2007		
							BETA MARINE LTD. DAVY WAY, WATERWELLS GLOUCESTER, G12 2AG, U.K. BETA MARINE TEL: (01453) 832282 FAX: (01453) 832284			

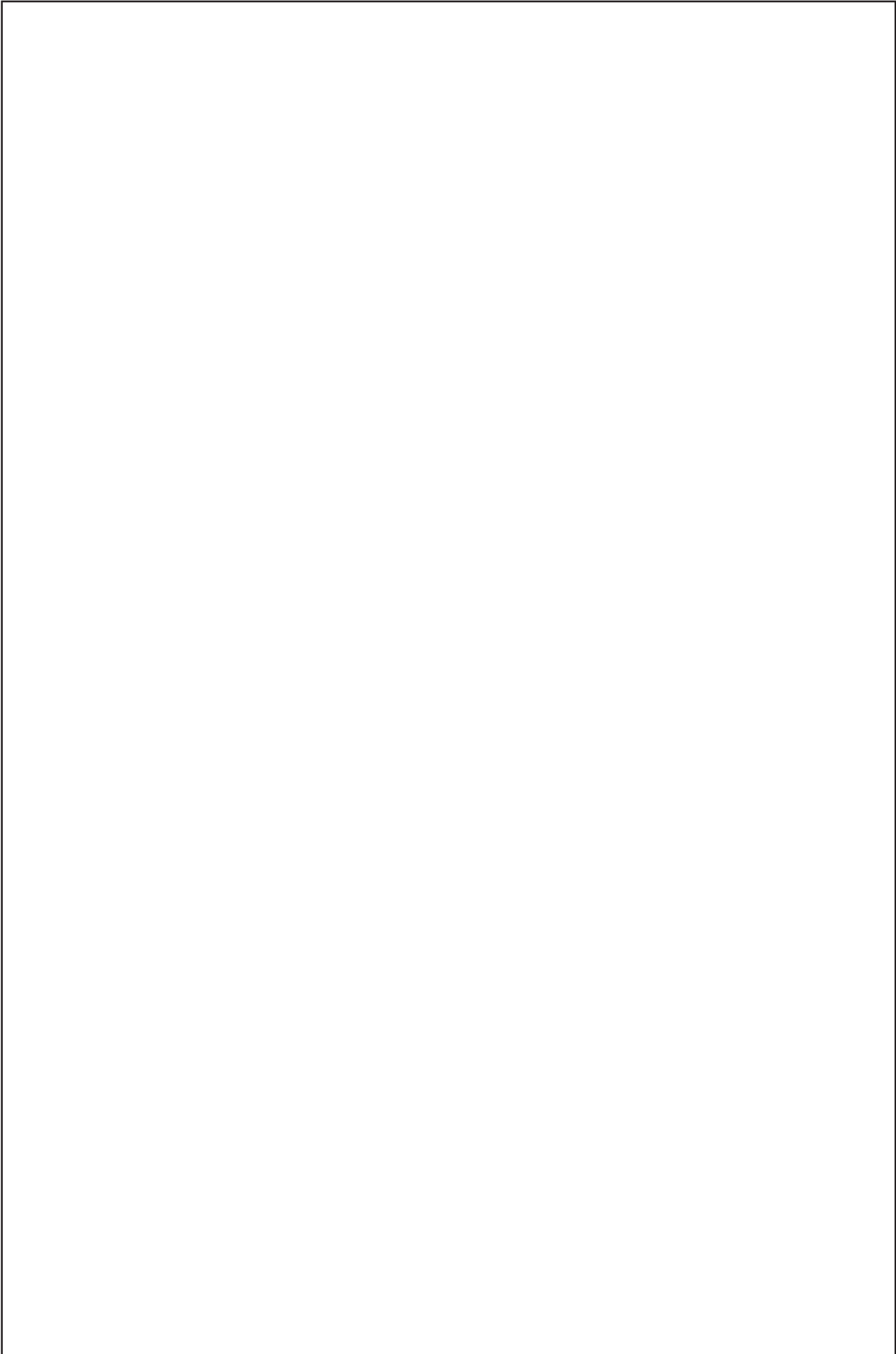

VIEW LOOKING ON CONNECTOR FACE
FITTED WITH FEMALE SPADE/BULLET

- 1 - 2.5mm BROWN/WHITE TRACER
- 2 - 2.5mm WHITE/RED TRACER
- 3 - 2.5mm WHITE/BLACK TRACER
- 4 - 1mm BROWN
- 5 - 1mm PURPLE
- 6 - 1mm BLACK/BLUE TRACER
- 7 - 1mm BLUE/GREEN TRACER
- 8 - 1mm WHITE/BROWN TRACER
- 9 - 1mm BROWN/YELLOW TRACER
- 10 - 1mm BLACK
- 11 - 2.5mm RED
- 12 - 1mm GREEN/YELLOW TRACER
- 13 - 1mm BLUE/YELLOW TRACER
- 14 - 1mm YELLOW

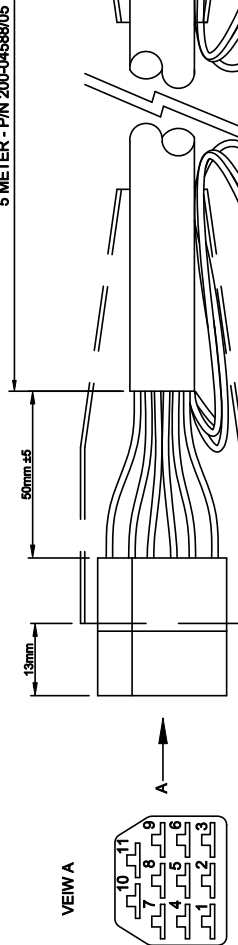

- 1 METER - P/N 200-04588/01
- 2 METER - P/N 200-04588/02
- 3 METER - P/N 200-04588/03
- 4 METER - P/N 200-04588/04
- 5 METER - P/N 200-04588/05

VIEW LOOKING ON CONNECTOR FACE
FITTED WITH MALE SPADE/BULLET

- 1 - 2.5mm BROWN/WHITE TRACER
- 2 - 2.5mm WHITE/RED TRACER
- 3 - 2.5mm WHITE/BLACK TRACER
- 4 - 1mm BROWN
- 5 - 1mm PURPLE
- 6 - 1mm BLACK/BLUE TRACER
- 7 - 1mm BLUE/GREEN TRACER
- 8 - 1mm WHITE/BROWN TRACER
- 9 - 1mm BROWN/YELLOW TRACER
- 10 - 1mm BLACK
- 11 - 2.5mm RED
- 12 - 1mm GREEN/YELLOW TRACER
- 13 - 1mm BLUE/YELLOW TRACER
- 14 - 1mm YELLOW

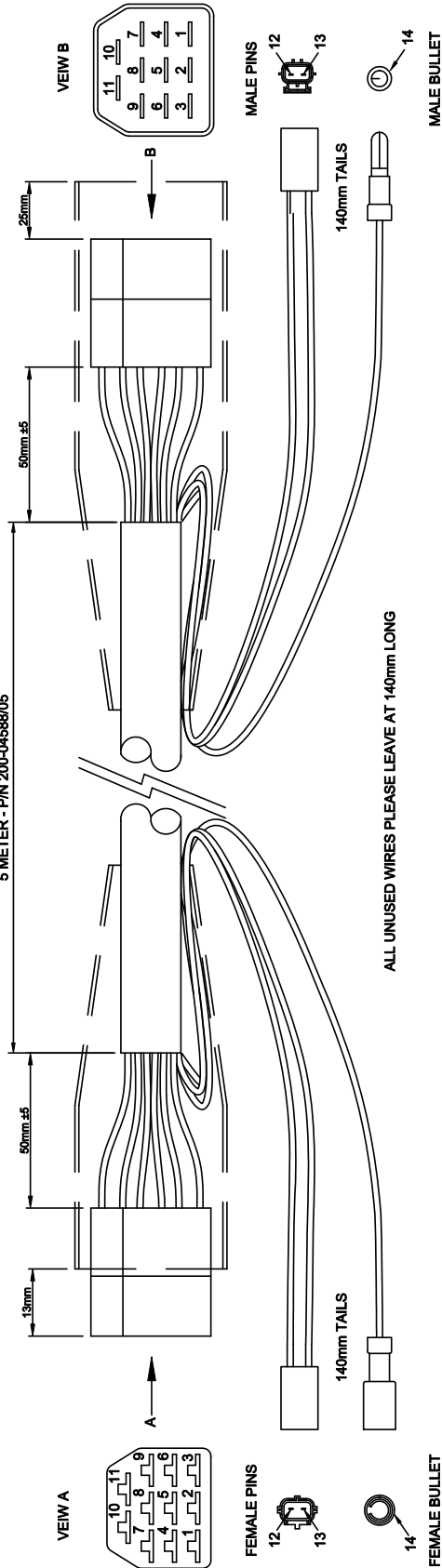

ALL UNUSED WIRES PLEASE LEAVE AT 140mm LONG

REV	DESCRIPTION	DATE	APP'D	DRAWN	NOTES
01					

EXTENSION HARNESS					
TITLE					
DRAWN BY:- TW		SIZE A4	DWG NO. 200-04588	REV 00	
CHECKED BY:- LT		SCALE NTS	PAGE 1 of 1	DATE 15/10/04	
DIMENSIONS IN MM (INCH) DO NOT SCALE					
BETA MARINE BETA MARINE LTD. DARTMOUTH, WIMBORNELEY, GLOUCESTERShire, GL2 2AD, U.K. TEL: (01453) 835282 FAX: (01453) 835284					

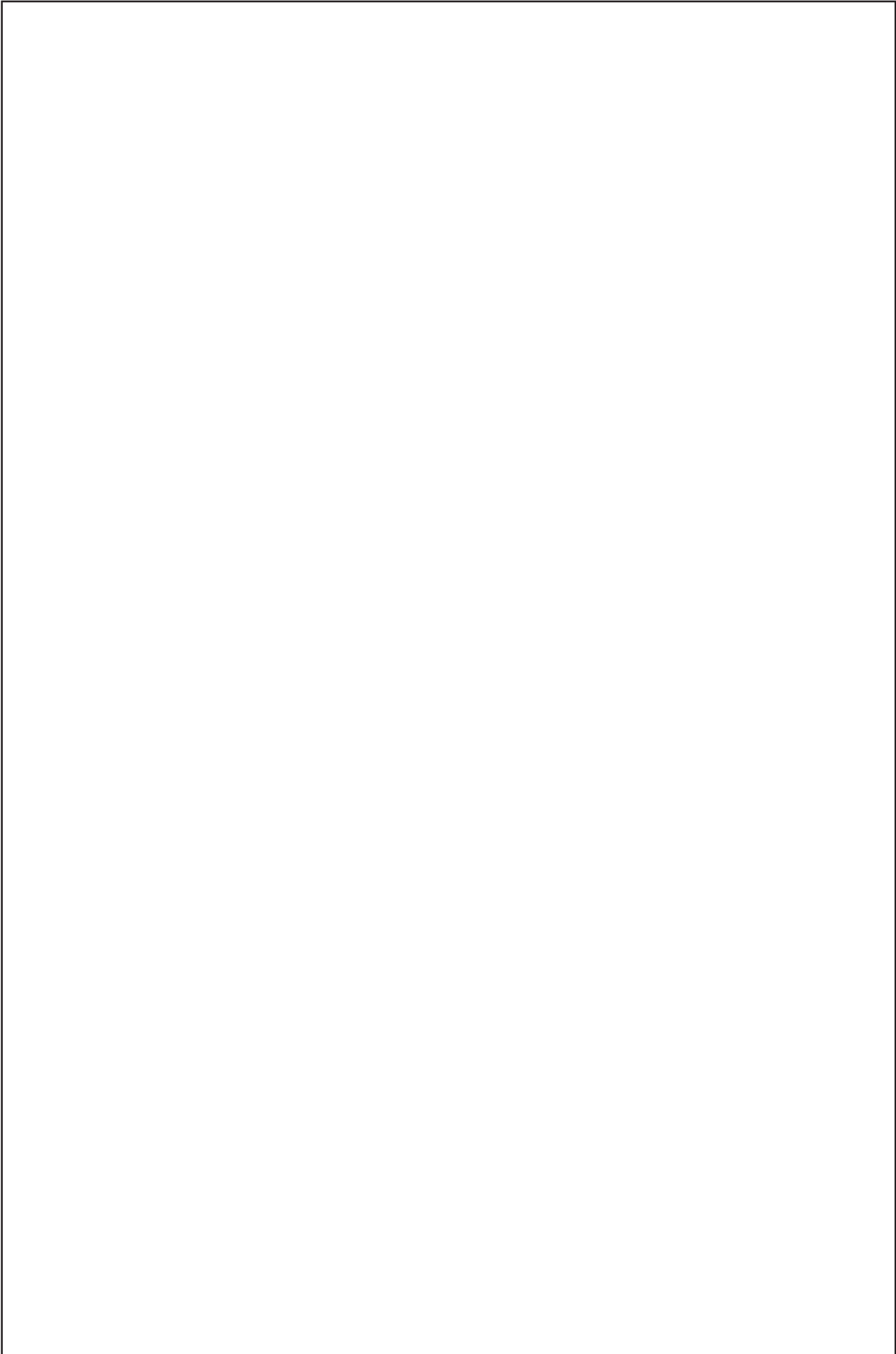

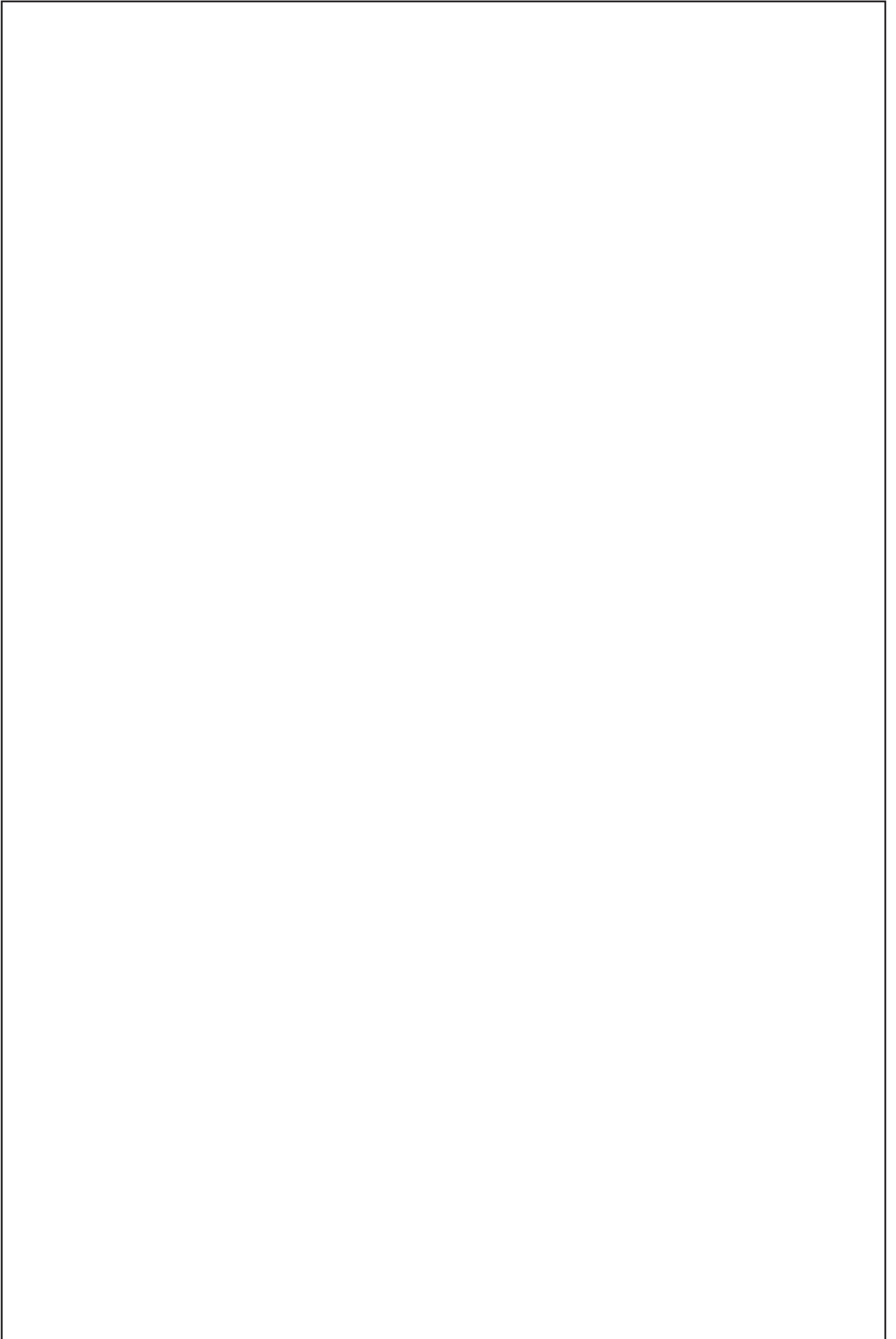

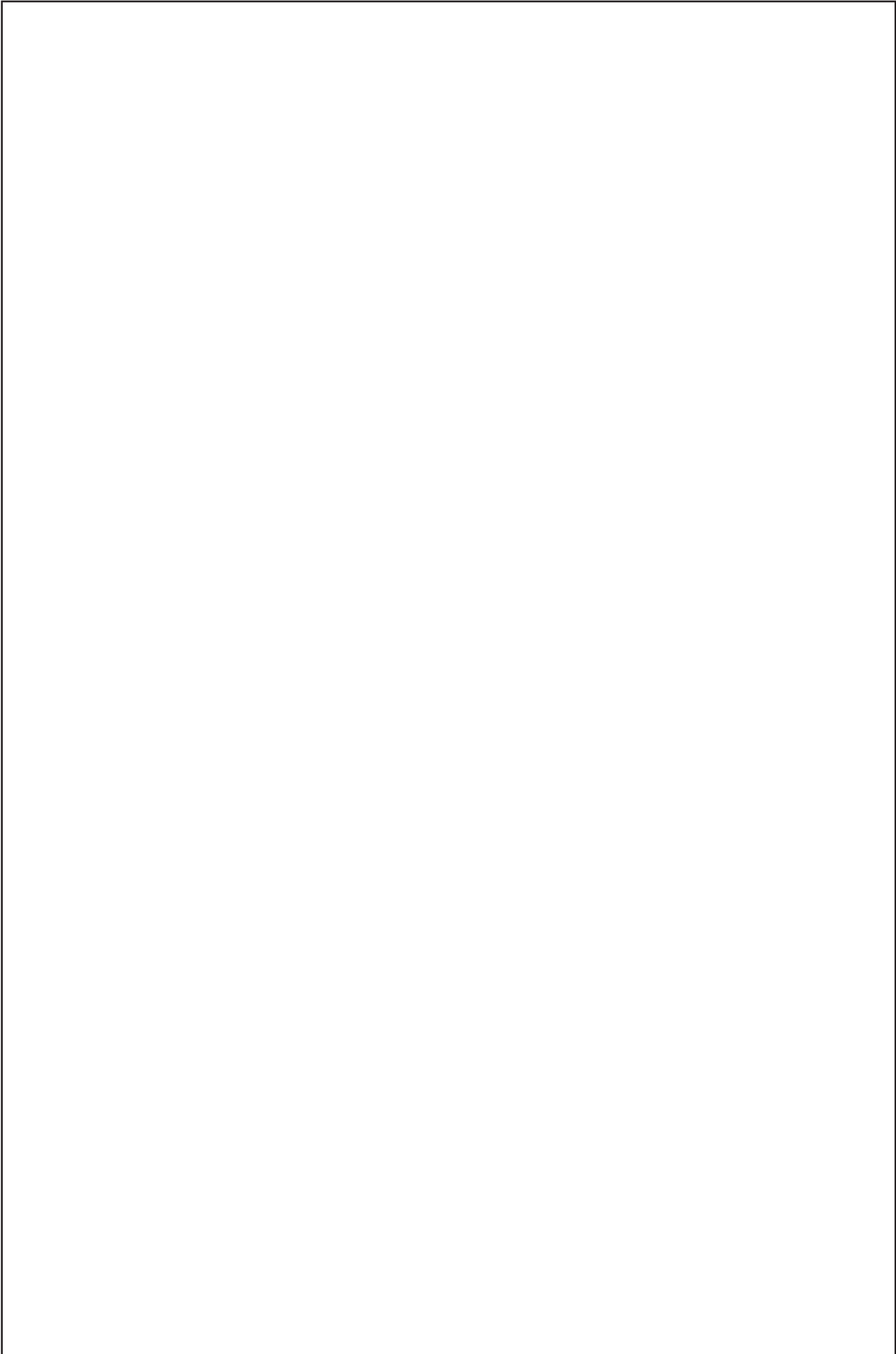

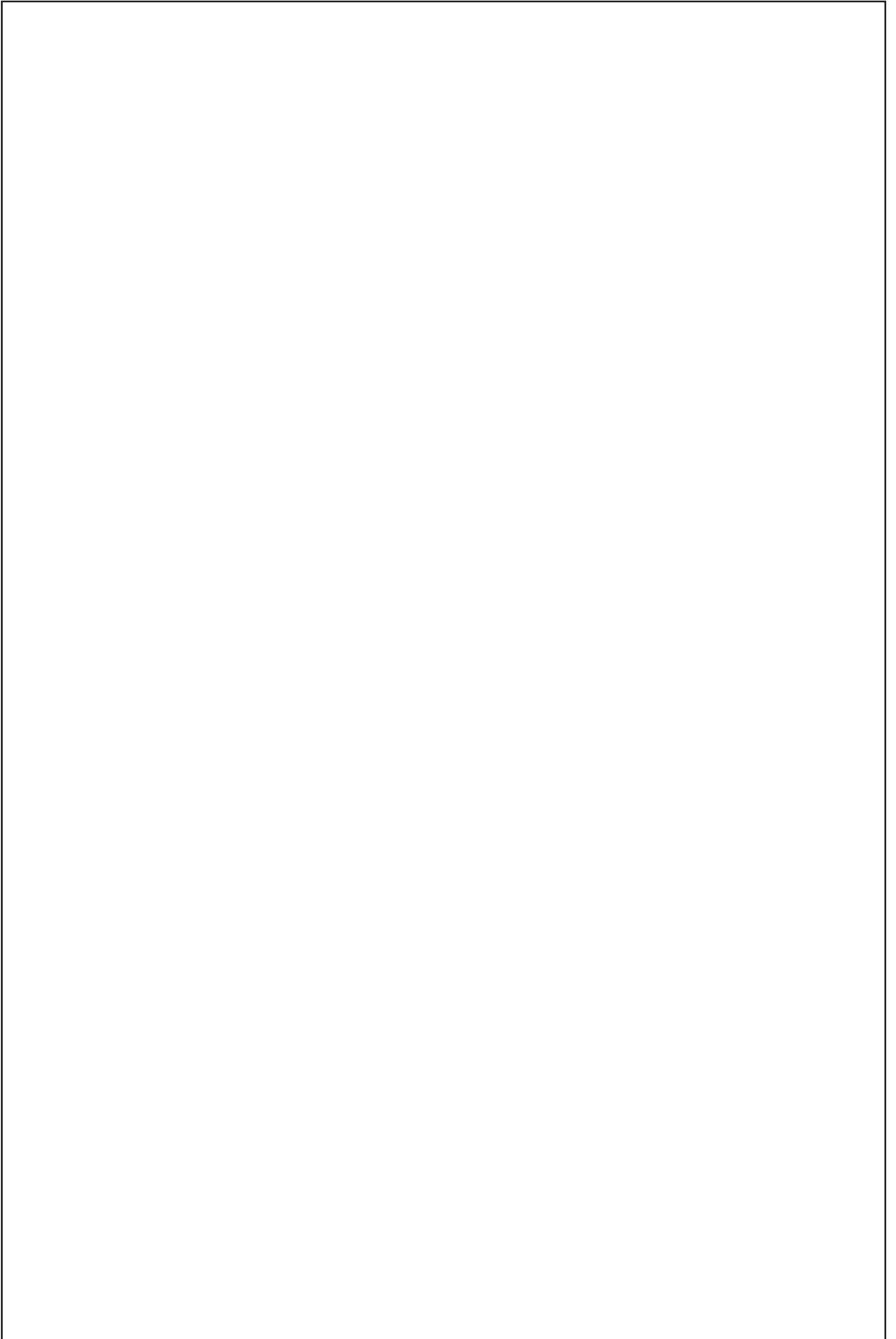

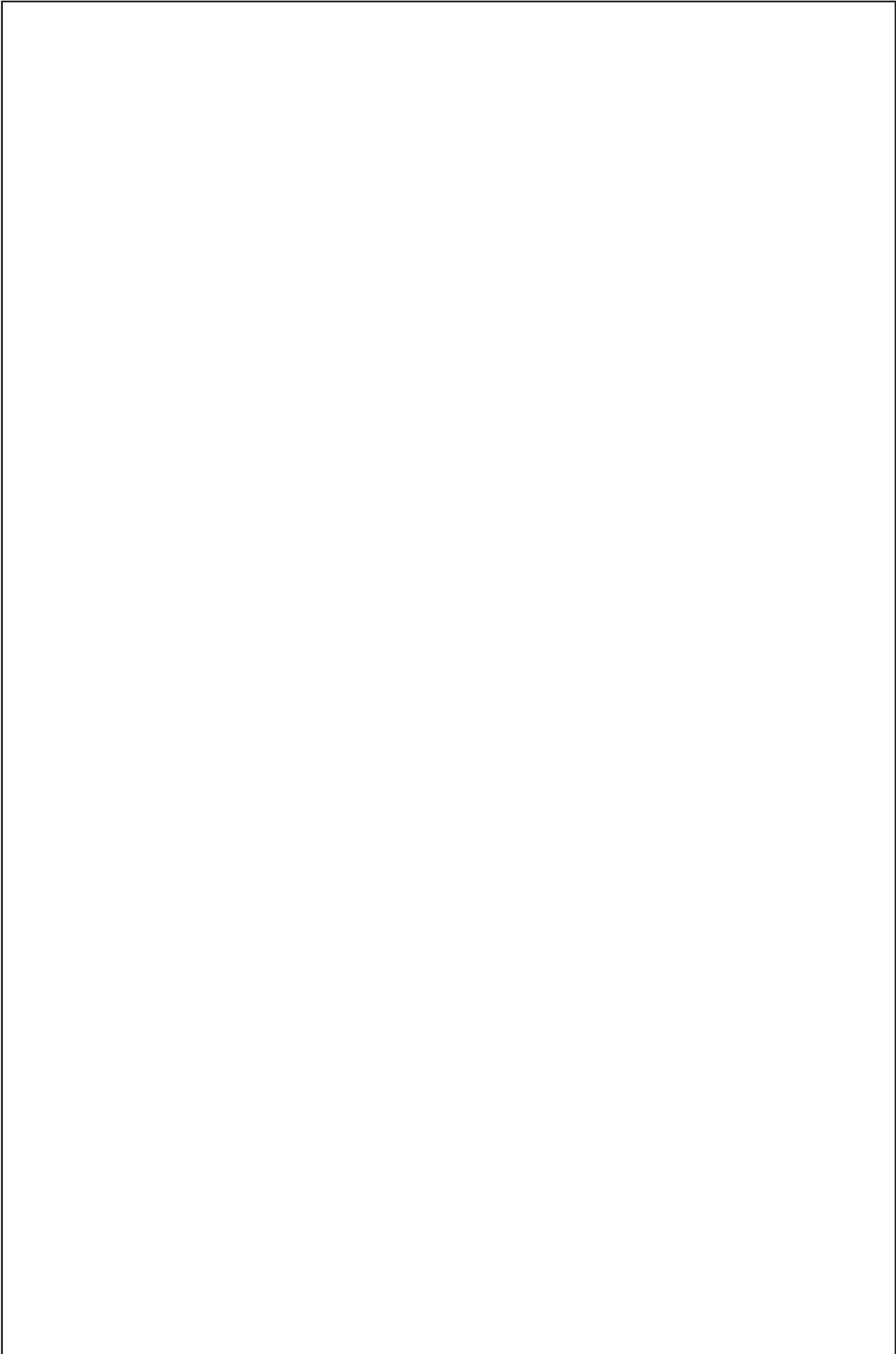

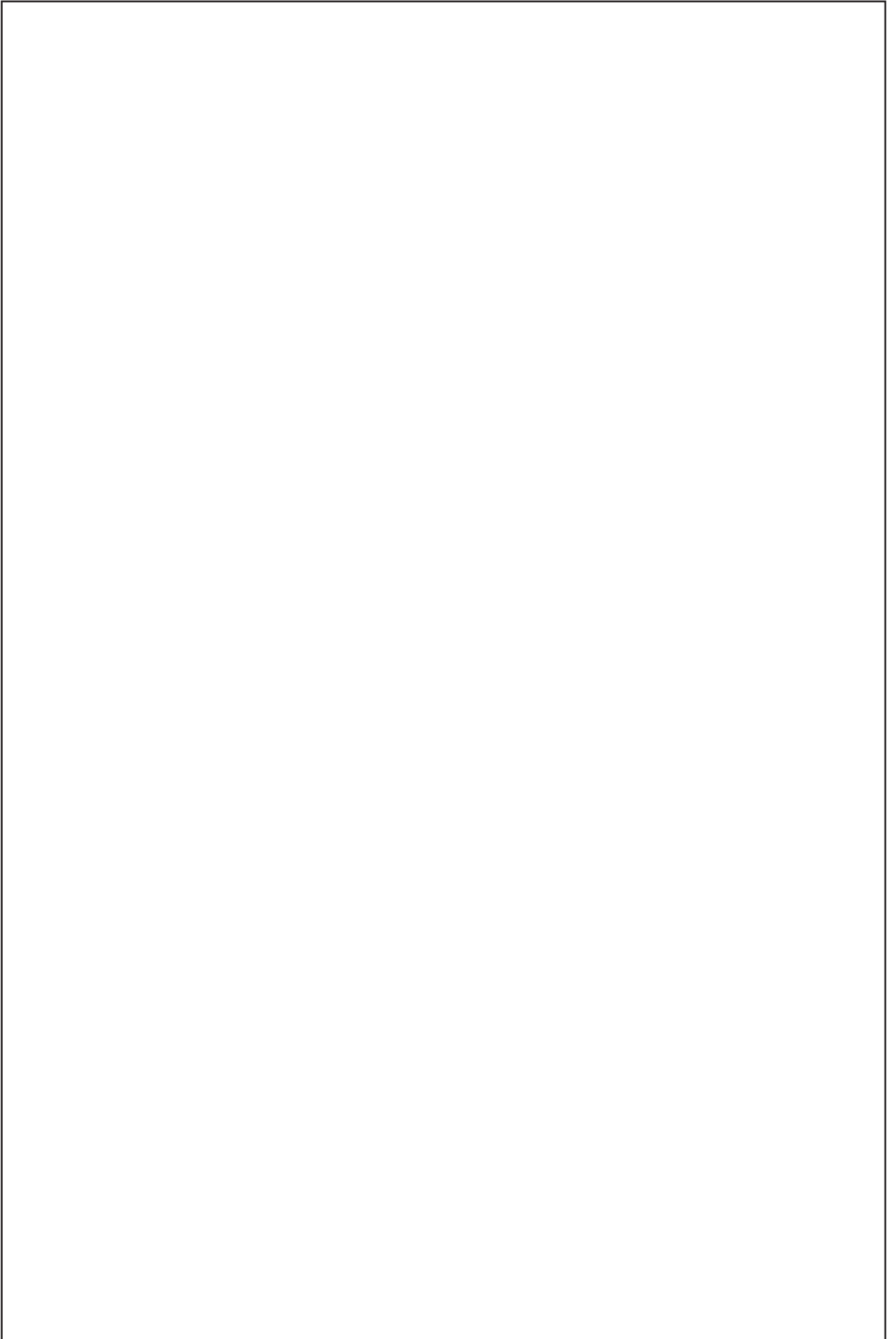

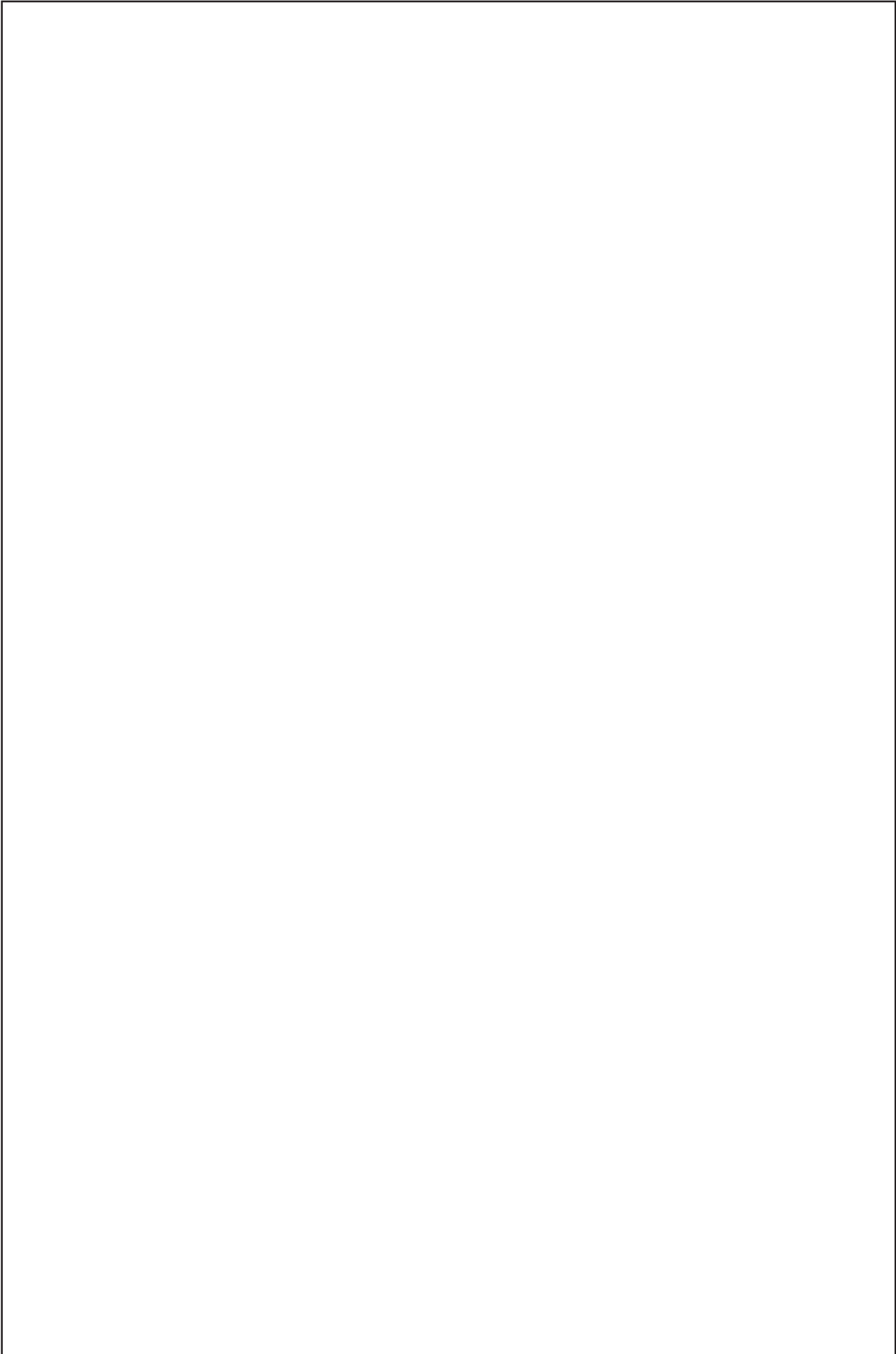

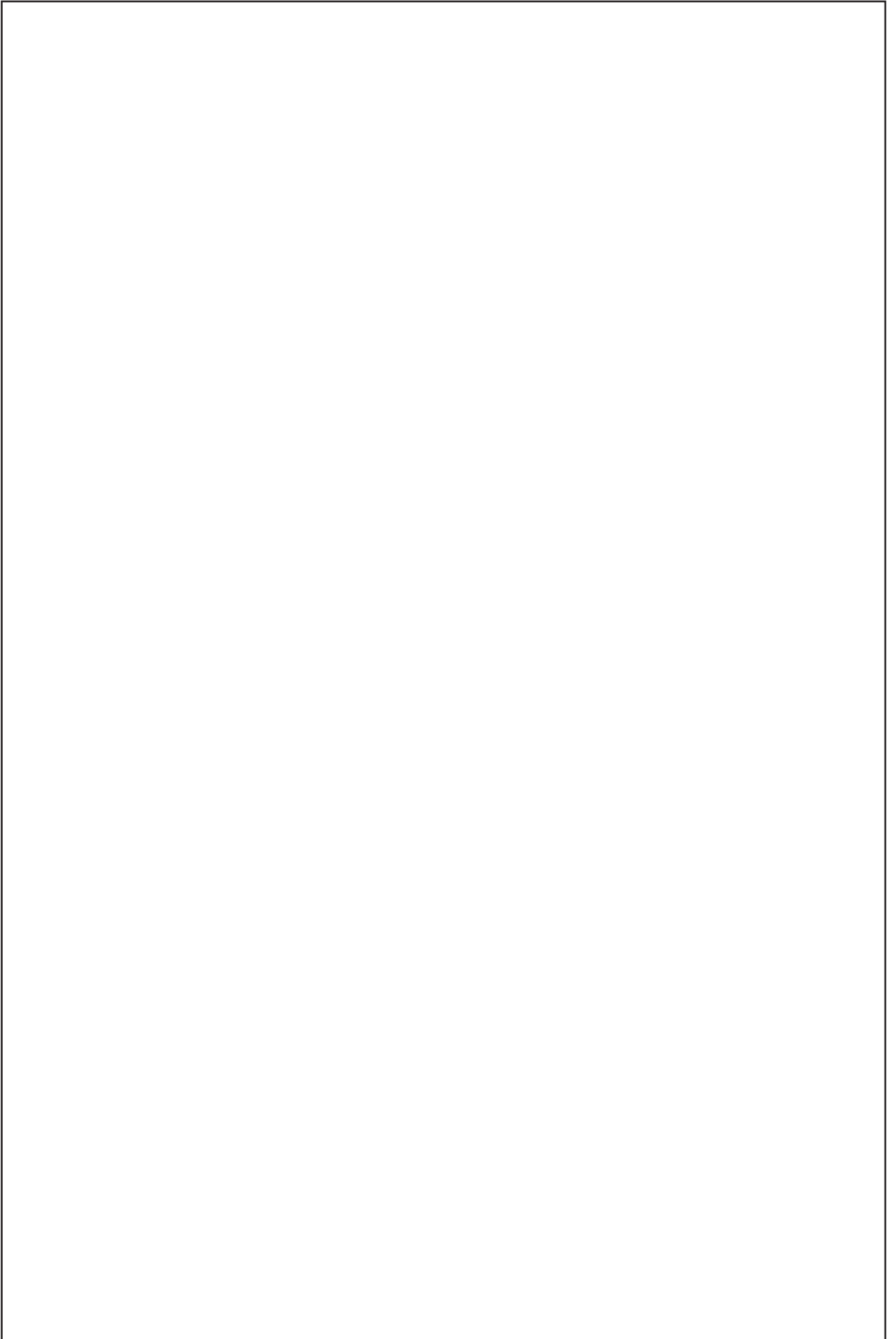

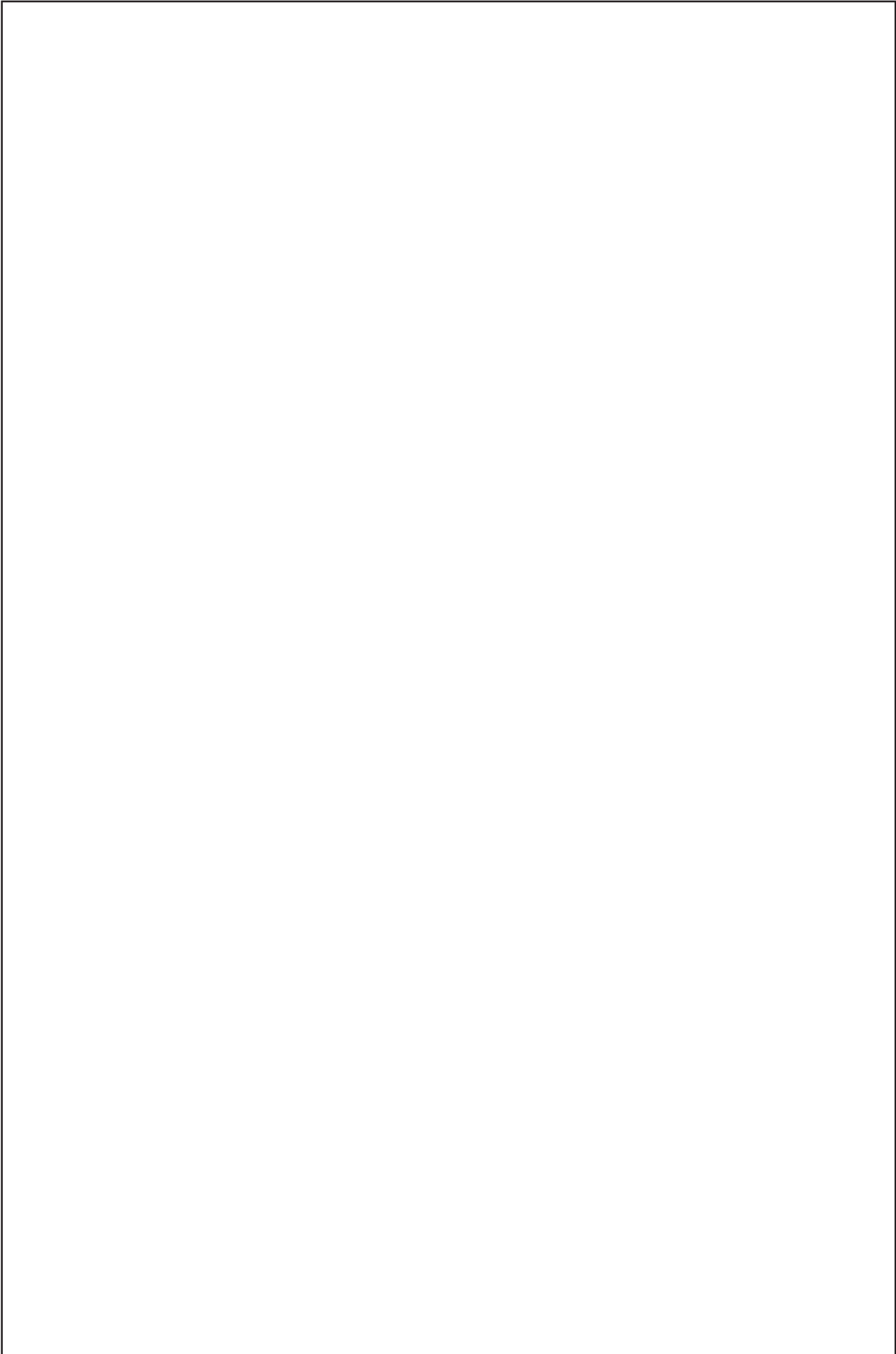

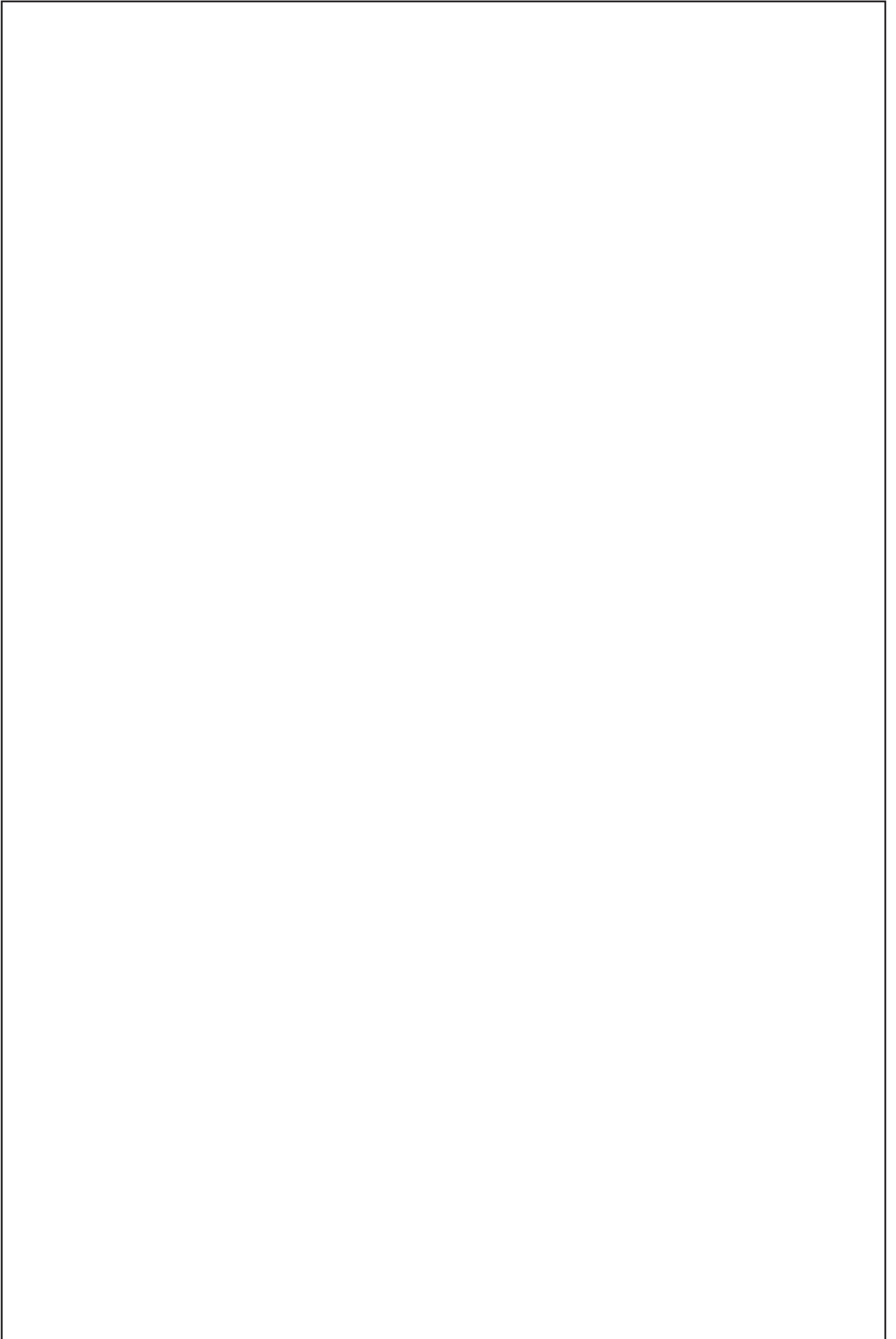

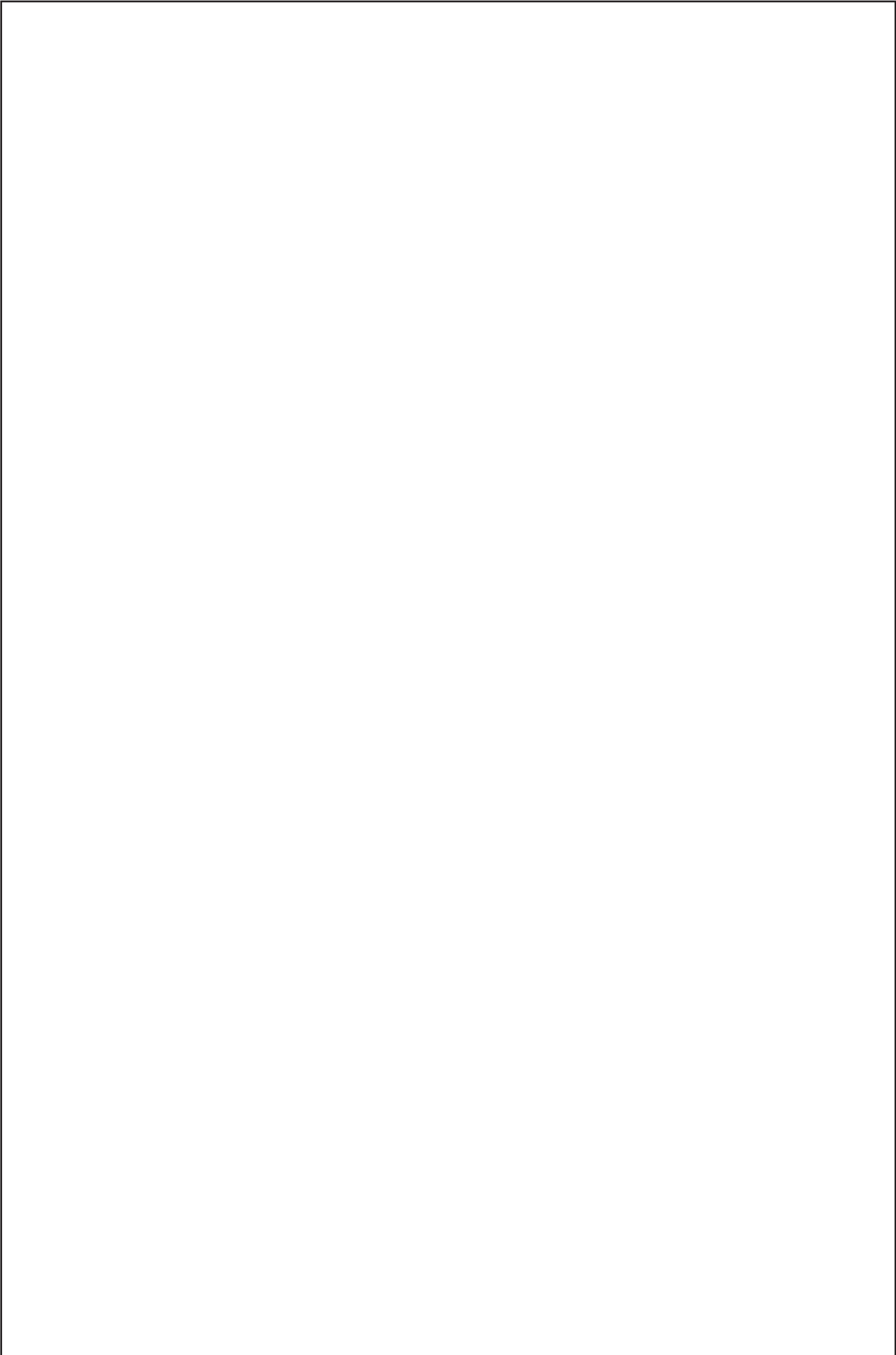

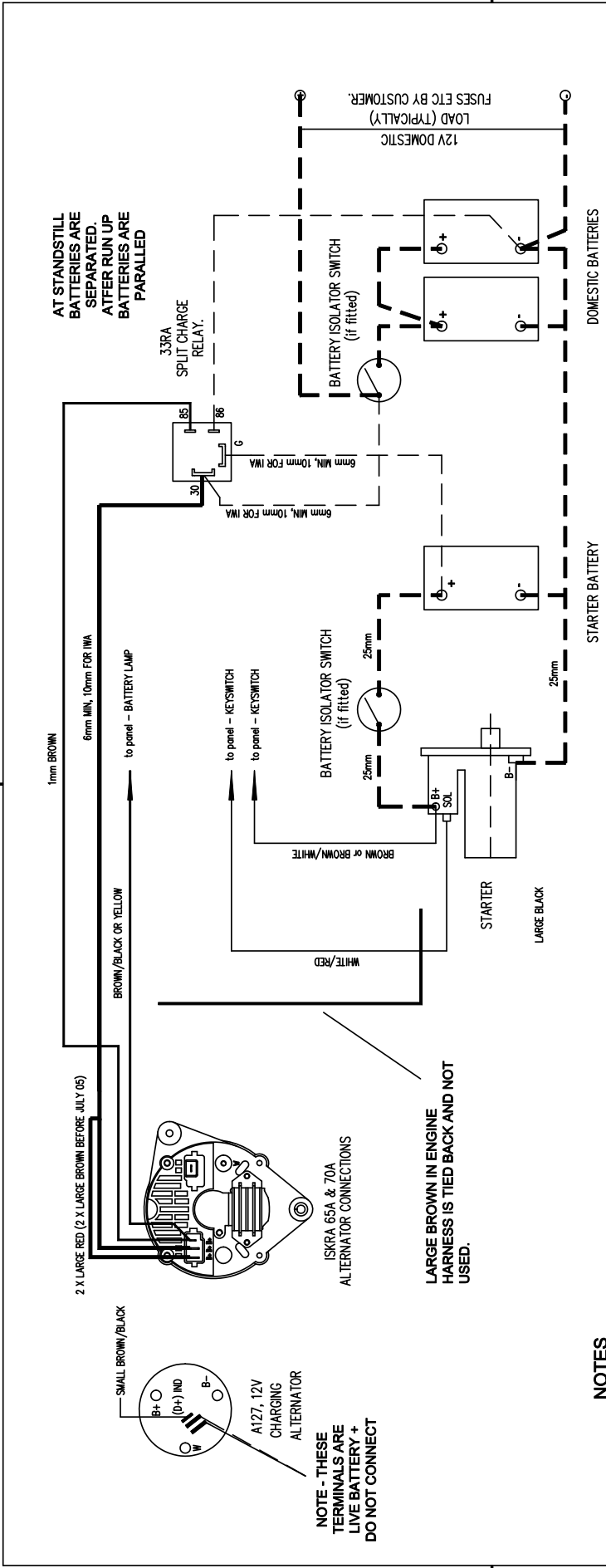

NOTES

IF BATTERY ISOLATOR(S) ARE FITTED THEY MUST BE CLOSED WHEN ENGINE IS STARTED AND RUNNING. THEY MUST NOT BE OPERATED WHEN THE ENGINE IS RUNNING AS THIS WILL DAMAGE THE ALTERNATOR.

BATTERY LEADS MUST BE INCREASED IN CSA FOR RUNS OVER 2M. CONSULT BETA. CABLES SHOWN BY DASHED LINES ARE CUSTOMER SUPPLY. RECOMMENDED MINIMUM CSA'S SHOWN.

WE RECOMMEND THE USE OF MULTISTRANDED CABLE TO BS 6862 PT. 1. - 25mm - 196/0.4(EPR/CSP) 6mm - 84/0.3 1mm - 14/0.3

BETA SPLIT CHARGE RELAY PT NO - 200-57640
 BETA BATT. ISOLATOR SWITCH PT NO - 200-62200
 REFER ALSO TO SPECIFIC ENGINE WIRING DIAGRAM(S)
 ALSO BETA MARINE NOTES "DUAL BATTERY CHARGING SYSTEMS".
 BATTERY LEADS, SWITCHES AND 33RA RELAY ARE OPTIONAL EXTRAS AND ARE ONLY SUPPLIED WHEN SPECIFICALLY ORDERED.

REV	DESCRIPTION	DATE	APP'D	NOTES	COMPLETE UNIT
01	REDRAWN ON CAD	01.08.2001	TW	FOR BLOCKING DIODE SYSTEM REFER TO DRAWING 300-62220. DRAWINGS 200-02189, 300-00212 SHEETS 1, 2 AND 3 ALSO RELATE TO SPLIT CHARGE AND INSULATED SYSTEMS.	TYPICAL INSALLATION FOR SPLIT CHARGE DUAL BATTERY SYSTEM, MACHINE SENSED ALTERNATORS.
02	MINOR MODIFICATIONS AND NOTES	10.10.2001	PAG		TITLE
03	CHANGED STD ALTERNATOR	05.06.2003	DM	(ISSUE 02+ OF THIS DRAWING ALSO REPLACES 300-97720).	SPLIT CHARGE RELAY INSTALLATION.
04	CHANGED NOTES	15.12.2005	DM		DWG NO. 300-62210
					DATE OCTOBER 1997
					SHEET 1 OF 1
					REV 04

BETA MARINE

DRAWN BY:-- PAG
 CHECKED BY:--

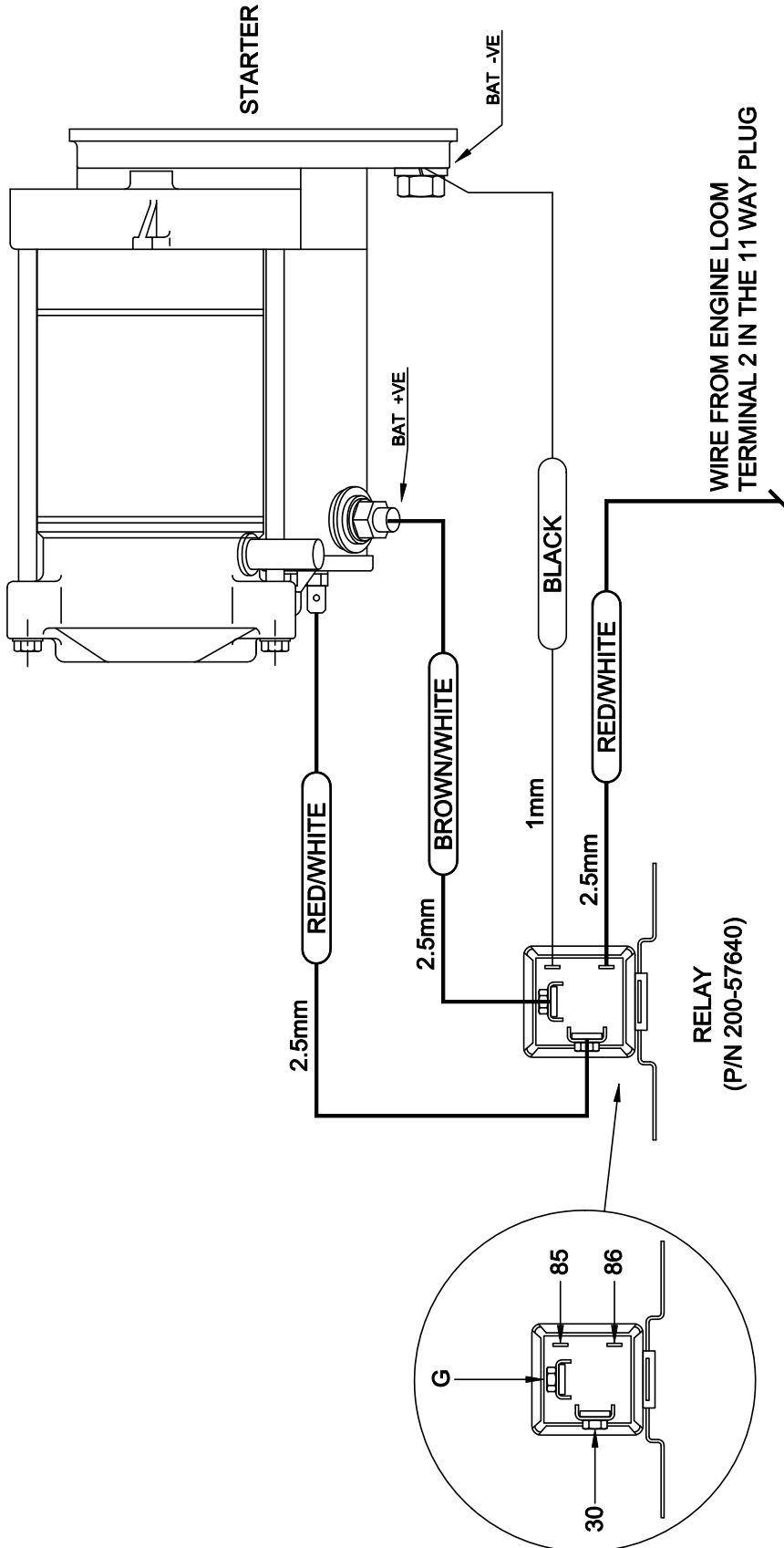

REV	DESCRIPTION	DATE	APPD	DRAWN	NOTES	TITLE	SCALE	PAGE	DATE	REV
01						STARTER BOOSTER RELAY FOR EXTENDED HARNESS OVER 4m TOTAL LENGTH	N/A	1 of 1	16/10/02	
DIMENSIONS IN MM (INCH) DO NOT SCALE BETA MARINE LTD, DAVEY WAY, WATERWELLS, QUEDGELEY, GLOUCESTER GL2 2AD, UK TEL: (01453) 835282 FAX: (01453) 835284 BETA MARINE							DRAWN BY: TW CHECKED BY: DM DWG NO: 300-58520	SIZE A4 SCALE N/A PAGE 1 of 1	DATE 16/10/02	REV

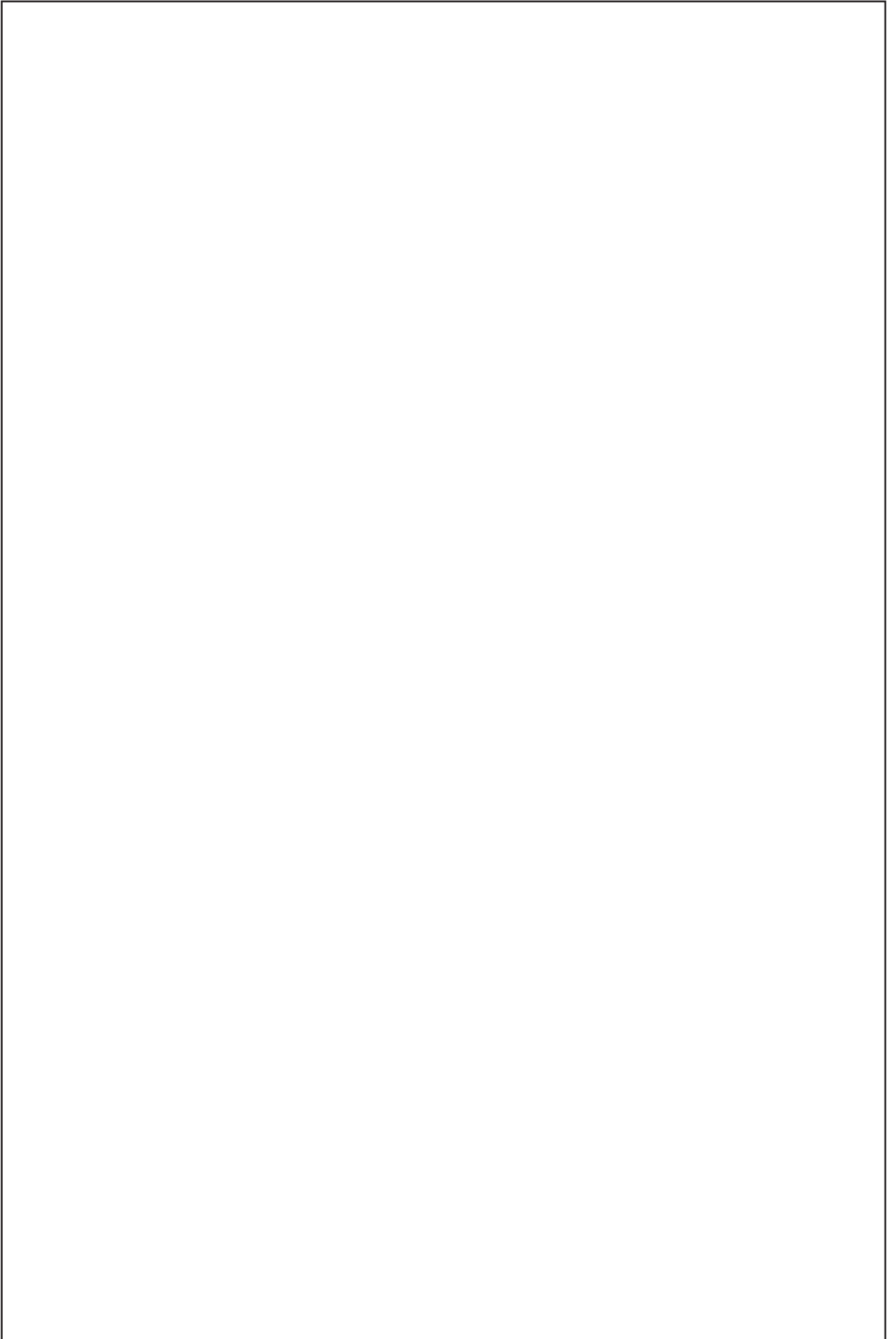

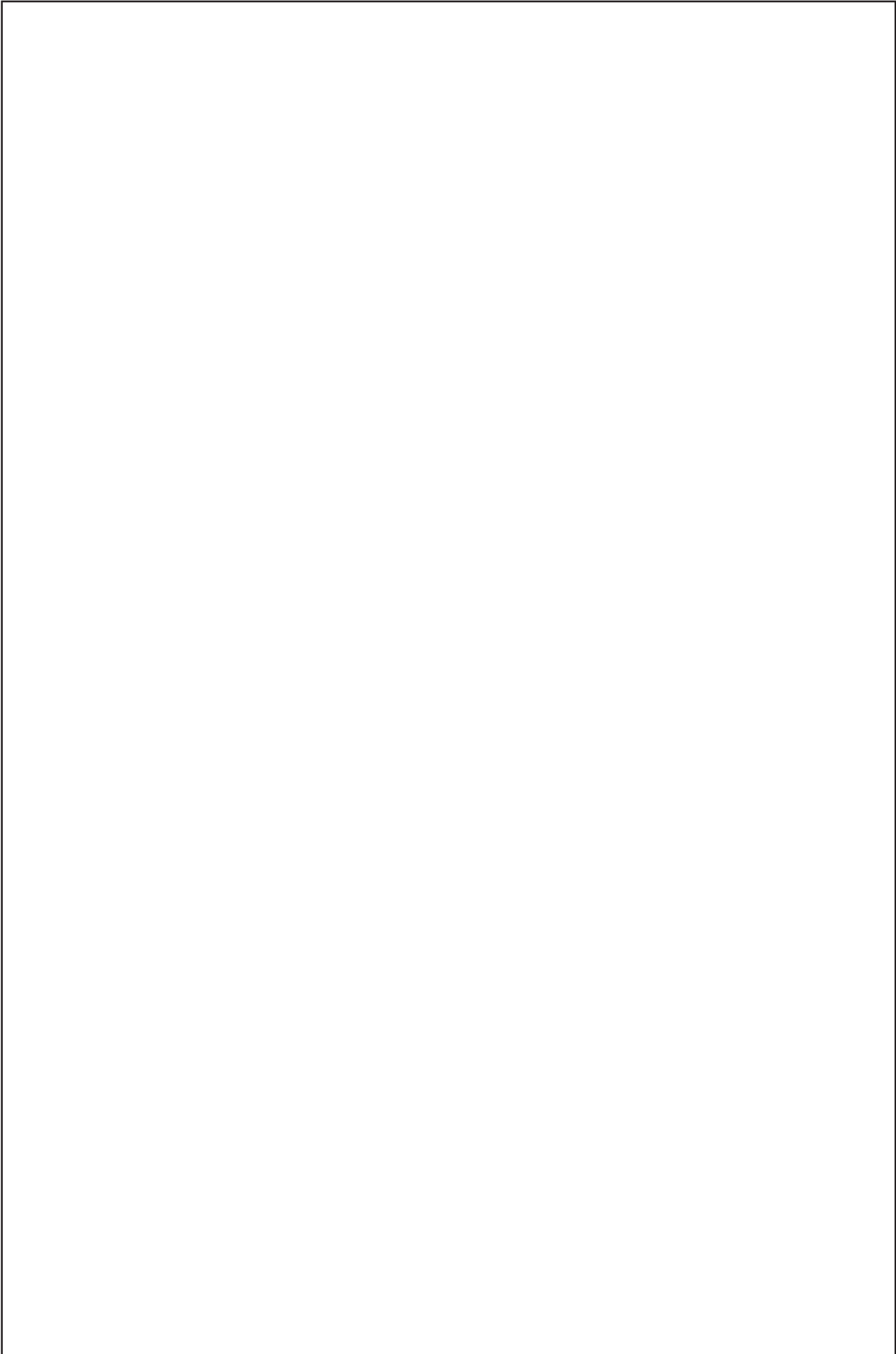

Declaration of Conformity for Recreational Craft Propulsion Engine with the Exhaust emission requirements of Directive 94/25/EC as amended by 2003/44/EC

(Completed by manufacturer of inboard engines without integral exhaust)

Name of engine manufacturer: Beta Marine Limited

Street: Davy Way, Waterwells

Town: Quedgeley, Gloucestershire

Post Code: GL2 2AD

Country: U.K.

Engine type-approved according to: Stage II of Directive 97/68/EC

DESCRIPTION OF ENGINES AND ESSENTIAL REQUIREMENTS

Engine type: Inboard engine.

Fuel type: Diesel gas oil JIS K2204:1997 or equal.

Combustion cycle: 4-stroke.

ENGINE(S) COVERED BY THIS DECLARATION

Engine models and engine family names:	EC Type certificate number (exhaust)
BD1105 BV1505 Beta 35/38 3KBXL01.5BCD	e1*97/68DA*2001/63*0160*00 e1*97/68DA*2004/26KA*0164*00
BD1703 Beta 39 BV1903 Beta 43 BV2003 Beta 43 BV2203 Beta 50 YKBXL02.2FCD	e1*97/68DA*2001/63*0072*05 e1*97/68DA*2004/26KA*0072*08 e1*97/68DA*2004/26KA*0072*09
BV2203 6KBXL02.2FCC	e1*97/68KA*2004/26*0375*00
BV2403 Beta 60 3KBXL02.4HCD	e1*97/68GA*2001/63*0147*01
BV3300 Beta 75 3KBXL03.3BCD	e1*97/68GA*2001/63*0145*00
BV3600 Beta 75 7KBXL03.6BCD	e1*97/68JA*2004/26*0430*00
BV3300T 3KBXL03.3BAD	e1*97/68GA*2001/63*0144*00
BV3800 Beta 90 3KBXL03.8ACD	e1*97/68GA*2001/63*0155*00

ENGINE(S) COVERED BY THIS DECLARATION

Engine models and engine family names:	EC Type certificate number (exhaust)
BZ602 Beta 16 BD902 Beta 25 3KBXL898KCD 7KBXL898KCB	e1*97/68DA*2002/88*0266*00
BD905 BD1005 Beta 28 BV1305 Beta 35 3KBXL01.3BCD	e1*97/68DA*2001/63*0157*00 e1*97/68DA*2004/26KA*0157*02

Essential requirements	Standards Used	Other normative document used	See technical file
Annex I.B – Exhaust Emissions			
engine identification	N/A	2033/44 annex 1B para 1.	QA025
exhaust emission requirements	N/A	2003/44 para 16, L214/19	EC type certificate has its own technical file.
durability	N/A	2033/44 annex 1B para 3.	QA033
owner's manual	BS EN ISO 10240	2033/44 annex 1B para 4.	N/A
Annex I.C – Noise Emissions	see craft manufacturer's Declaration of Conformity		

I declare on behalf of the engine manufacturer that the engine(s) will meet the exhaust emission requirements of Directive 94/25/EC as amended by Directive 2003/44/EC when installed in a recreational craft, in accordance with the engine manufacturer's supplied instructions and that this (these) engine(s) must not be put into service until the recreational craft into which it is (they are) to be installed has been declared in conformity with the relevant provisions of the above mentioned Directive

Name J. A. Growcoat
(identification of the person empowered to sign on behalf of the engine manufacturer)

Signature and title:



C.E.O.

Date: (yr/month/day) 2008 / 10 / 22 Quedgeley, Gloucestershire
Certificate 2.03 Revision 05, latest EU certificate numbers added.

Declaration of Conformity for Recreational Craft Propulsion Engine with the Exhaust emission requirements of Directive 94/25/EC as amended by 2003/44/EC

(Completed by manufacturer of inboard engines without integral exhaust)

Name of engine manufacturer: Beta Marine Limited

Street: Davy Way, Waterwells

Town: Quedgeley, Gloucestershire

Post Code: GL2 2AD

Country: U.K.

Engine type-approved according to: Stage II of Directive 97/68/EC

DESCRIPTION OF ENGINES AND ESSENTIAL REQUIREMENTS

Engine type: Inboard engine.

Fuel type: Diesel gas oil JIS K2204:1997 or equal.

Combustion cycle: 4-stroke.

ENGINE(S) COVERED BY THIS DECLARATION	
Engine models and engine family names:	EC Type certificate number (exhaust)
BD1105 BV1505 Beta 35/38 3KBXL01.5BCD	e1*97/68DA*2001/63*0160*00 e1*97/68DA*2004/26KA*0164*00
BD1703 Beta 39 BV1903 Beta 43 BV2003 Beta 43 BV2203 Beta 50 YKBXL02.2FCD	e1*97/68DA*2001/63*0072*05 e1*97/68DA*2004/26KA*0072*08 e1*97/68DA*2004/26KA*0072*09
BV2203 6KBXL02.2FCC	e1*97/68KA*2004/26*0375*00
BV2403 Beta 60 3KBXL02.4HCD	e1*97/68GA*2001/63*0147*01
BV3300 Beta 75 3KBXL03.3BCD	e1*97/68GA*2001/63*0145*00
BV3600 Beta 75 7KBXL03.6BCD	e1*97/68JA*2004/26*0430*00
BV3300T 3KBXL03.3BAD	e1*97/68GA*2001/63*0144*00
BV3800 Beta 90 3KBXL03.8ACD	e1*97/68GA*2001/63*0155*00

ENGINE(S) COVERED BY THIS DECLARATION	
Engine models and engine family names:	EC Type certificate number (exhaust)
BZ602 Beta 16 BD902 Beta 25 3KBXL898KCD 7KBXL898KCB	e1*97/68DA*2002/88*0266*00
BD905 BD1005 Beta 28 BV1305 Beta 35 3KBXL01.3BCD	e1*97/68DA*2001/63*0157*00 e1*97/68DA*2004/26KA*0157*02

Essential requirements	Standards Used	Other normative document used	See technical file
Annex I.B – Exhaust Emissions			
engine identification	N/A	2033/44 annex 1B para 1.	QA025
exhaust emission requirements	N/A	2003/44 para 16, L214/19	EC type certificate has its own technical file.
durability	N/A	2033/44 annex 1B para 3.	QA033
owner's manual	BS EN ISO 10240	2033/44 annex 1B para 4.	N/A
Annex I.C – Noise Emissions		see craft manufacturer's Declaration of Conformity	

I declare on behalf of the engine manufacturer that the engine(s) will meet the exhaust emission requirements of Directive 94/25/EC as amended by Directive 2003/44/EC when installed in a recreational craft, in accordance with the engine manufacturer's supplied instructions and that this (these) engine(s) must not be put into service until the recreational craft into which it is (they are) to be installed has been declared in conformity with the relevant provisions of the above mentioned Directive

Name J. A. Growcoat

Signature and title:



C.E.O.

(identification of the person empowered to sign on behalf of the engine manufacturer)

Date: (yr/month/day) 2008 / 10 / 22 Quedgeley, Gloucestershire

Certificate 2.03 Revision 05, latest EU certificate numbers added.

Emission durability

In respect to the Recreational Craft Directive 94/25/EC and amendment 2003/44/EC Annex 1, B3.

The engine must be installed, maintained and operated within the parameters detailed in the Operator's Maintenance Manual. Maintenance must use approved materials, parts and consumables. Should the engine lie unused for a period in excess of 6 months it must be inhibited otherwise it will deteriorate with resulting decrease in performance. See also the Winterising and Laying Up procedures in the Operator's Maintenance Manual.

The fuel settings of the diesel injection system must not be tampered with otherwise the guarantee will be invalid and the performance may fall outside prescribed limit. Such adjustment cannot be allowed under the terms of the emission certification.

Performance of the engine depends upon the use of correct fuels, lubricants and inhibitors. These are fully detailed in the Operator's Maintenance Manual.

Particular attention must be paid to the installation with respect to the exhaust system. The system must be designed so that water cannot back feed into the engine. The run must be such that the back pressure at the engine manifold does not exceed the level detailed in the Operator's Maintenance Manual. Wet, water injected, exhaust systems must be at least the bore mentioned in the Operator's Maintenance Manual and should the run be excessive this bore must be increased accordingly. Back pressure is measured at the outlet of the engine manifold before the water injection bend or dry bellows.

Our experience over 19 years has shown that properly installed and maintained engines hold their performance without major mishap even when running hours exceed those mentioned in the Recreational Craft Directive. It is the owners / users responsibility to ensure that the engine continues to function properly and any malfunction must be immediately investigated. The Trouble Shooting section as detailed in the Operator's Maintenance Manual is particularly helpful in this respect. Engine performance, especially with respect to erratic running, exhaust condition, low power output and high oil consumption are indications of engine conditions that may result in emissions outside the prescribed limits and must therefore be investigated and rectified immediately.

Fast Moving Parts Listings

H/E & K/C: **Beta 75 & 90**. In all cases please quote **Beta Marine WOC "K" number** and Engine type.

Description	Part Number	Qty per Engine
Control Panel Standard Key (To June '08)	600-00058	A Pair
Control Panel Standard Key (From June '08)	600-00058/01	A Pair
Control Panel Key Switch (To June '08)	600-00057	A Pair
Control Panel Key Switch (From June '08)	600-00057/01	A Pair
Control Panel Stop Button (and Heat & Start on ABWW)	200-00072	1
Tachometer , 0 - 3000 rpm with Digital Hour Counter	200-02373/03	1
Water Temperature Switch Gauge (B & C Panels)	200-96200	1
Oil Pressure Switch Gauge (C Panel Only)	200-96190	1
Voltmeter (C Panel Only)	200-96210	1
Green Power On Indicator Lamp & Retaining Clip	200-04656	1
Stop Warning Indicator Lamp & Retaining Clip	200-04657	3 or 4
Alarm Board (All Panels from June '05)	200-04655	1
Relay 12 Volt 40Amp (28Ra) Fitted to Rear of Panels	200-87020	1
Fuse (Blade) 40Amp	200-00959	1
Standard Engine Harness	200-05267	1
Water Temperature Switch (A, ABV & ABWW Panels)	200-01133	1
Water Temperature Sender (C & B Panels)	200-94360	1
Oil Pressure Switch (A, ABV & ABWW Panels)	600-62670	1
Oil Pressure Sender (C & B Panels)	200-94350	1
Cylinder Head Gasket	600-00253	1
Top Gasket Set	600-01099	1
Lower Gasket Set	600-01100	1
Rocker Cover Gasket	600-00257	1
Flexible Mount - Large 55 Shore Metalastic Type	213-96970/01	1
Flexible Mount - Large 65 Shore Metalastic Type	213-02646/02	1
Extended Dip Stick Guide & Stick Kit (Requires Bending)	600-96320	1
Manuals		
Operators Maintenance Manual	221-06346	1
Workshop Manual – Beta 75	600-00759	1
Workshop Manual – Beta 90	600-07082	1
Spare Parts Manual – Beta 75	600-00228	1
Spare Parts Manual – Beta 90	600-07083	1

Note: the above part numbers are suitable for earth return installations only (where battery negative cable is connected directly to engine ground).

For insulated earth (where battery negative cable is isolated from engine ground) different harnesses, alternators, switches for oil pressure and engine temperature will be required.

Fast Moving Parts Listings

H/E & K/C: **Beta 75 & 90**. In all cases please quote **Beta Marine WOC "K" number** and Engine type.

Description	Part Number	Qty per Engine
Wasting Zinc Anode	209-61840	1
Heat Exchanger " O " Ring	209-00814	2
Exhaust Elbow Gasket	600-98960	1
Pressure Cap (Not USA)	209-80130	1
60mm Water Injection Bend Elbow (From Oct. '02)	202-02951	1
Thermostat	600-00581	1
Thermostat Gasket (To Sept. '04)	600-00582	1
Thermostat Gasket (From Oct. '04)	600-04360	1
Drive Plate SAE10 - PRM260	206-97010	1
Drive Plate SAE10 - PRM500	206-04295	1
Drive Plate SAE10 - ZF25 / BW71C	206-00090	1
Standard Alternator	600-00632	1
Standard Alternator Vee-Belt	214-94260	1
Iskra 95Amp Alternator (Requires Poly-Vee Drive)	200-01167	1
Iskra 95Amp Alternator Vee-Belt	214-02142	1
Plunge Type Fuel Filter (To '08) Approx. 115 mm OAL	211-02817	1
Plunge Type Fuel Filter (From '08) Approx. 70 mm OAL	211-60210	1
Plunge Type Fuel Filter (Beta 90, from '08) Approx. 115 mm OAL	211-02817	1
Oil Filter	211-70510/02	1
Air Cleaner Element (To Jan '04)	211-96980	1
Air Cleaner Element (To Aug '09)	211-04109	1
Air Cleaner Element (From Sept '09)	211-03819	1
Sump Drain Pump	210-80061	1
Sump Drain Pump Clamp	212-00793	2
Sea Water Pump	207-01178	1
Sea Water Pump Impellor	207-98880	1
Sea Water Pump Gasket	207-01101	1
Sea Water Pump End Cover Plate	207-01102	1
Sea Water Pump End Cover Plate Screw	207-01103	1
Sea Water Pump Service Kit	207-01104	1
Tube Stack	209-02846	1
Fuel Lift Pump	600-01466	1
Fuel Stop Solenoid (Energised to stop , to '08)	200-94370	1
Fuel Stop Solenoid (Energised to run , from '08)	600-00627	1
Fuel Stop Solenoid (Energised to stop , from Oct '09)	200-94370	1

Service Record

	Service	Date	Responsible	
1	Commissioned			
2	First 25 hours			
3	First 50 hours			
4	Every 150 hours with shallow sump			
5	Every Year / Every 250 hours if sooner			
6				
7				
8				
9	Every 750 hours			
10				
11				
12				
13				
14				
15				
16				

Heat Exchanger Cooled
10 to 90bhp

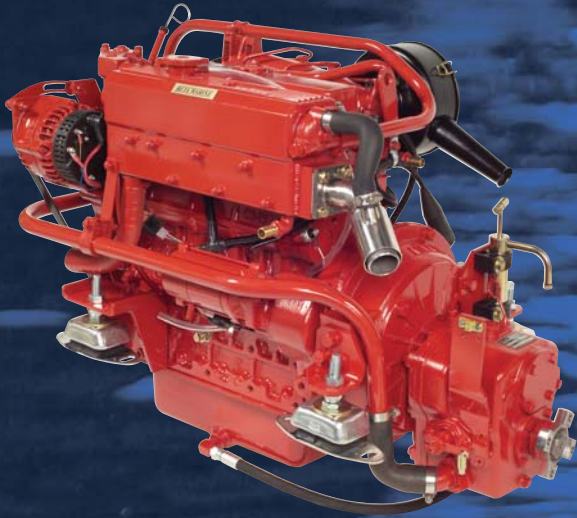

Keel Cooled
10 to 90bhp



Marine Generating Sets
3.7 to 40kVA



Sail Drives
13.5 to 50bhp



BETA MARINE

Beta Marine Limited
Davy Way, Waterwells
Quedgeley, Gloucester
GL2 2AD, UK.

Tel: 01452 723492
Fax: 01452 883742
Email: sales@betamarine.co.uk
www.betamarine.co.uk

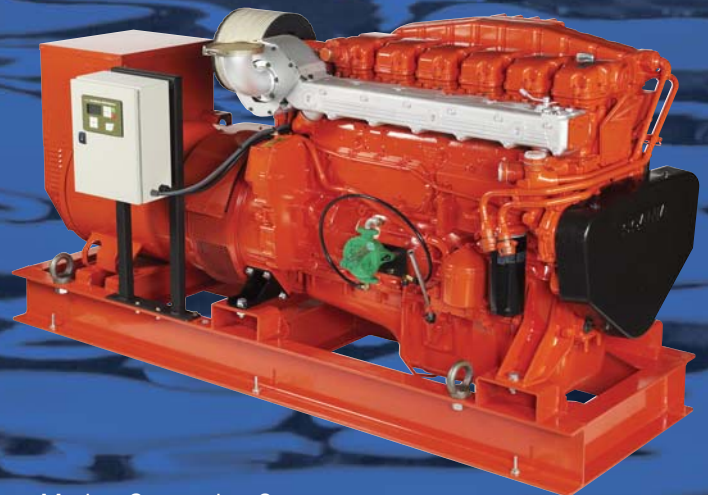

Marine Generating Sets
30 to 900kVA