

BETA MARINE

Small Diesel Engine Range

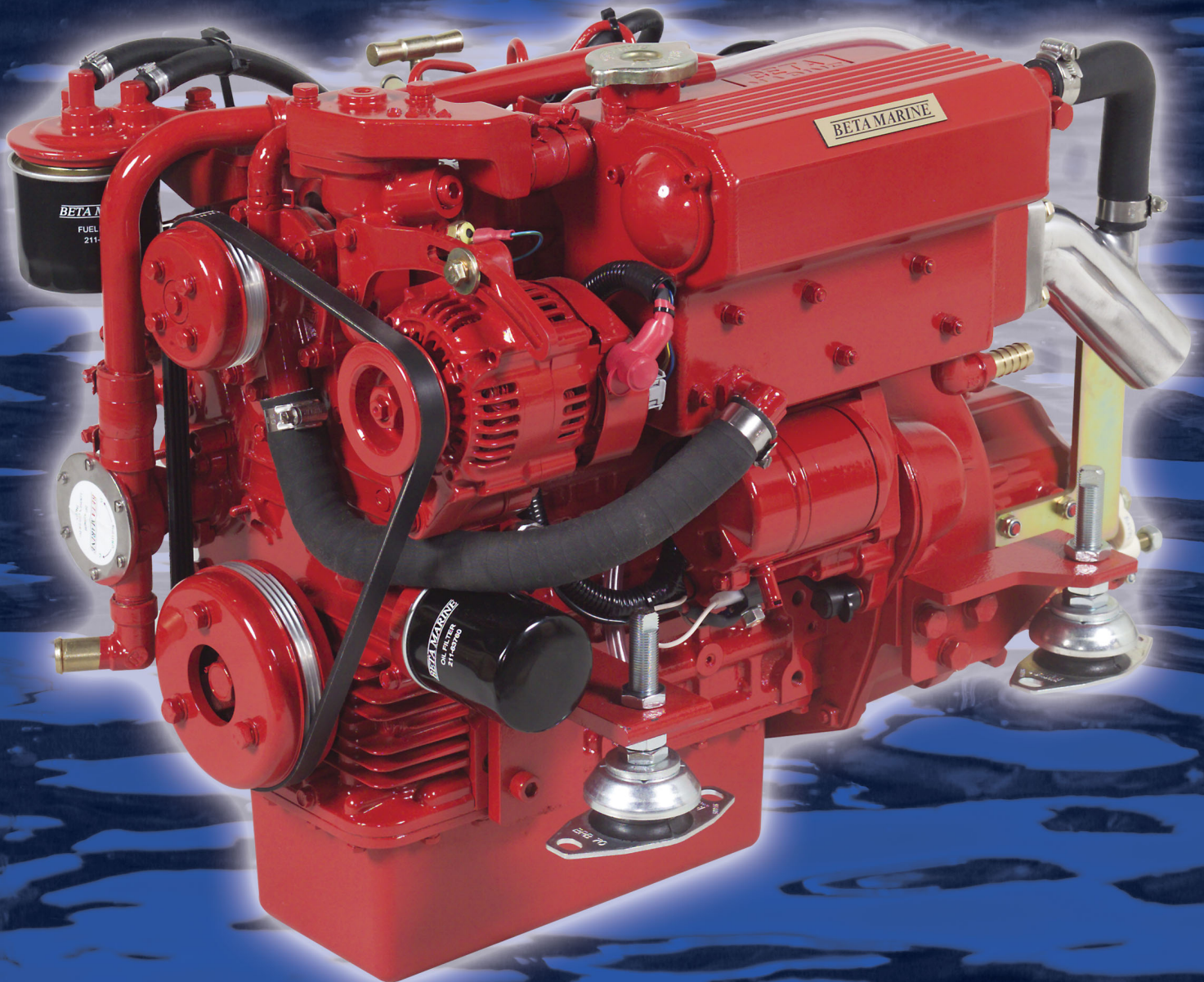

**Heat Exchanger Cooled 10 to 38 hp
The Yachtsman's Choice**

Why Beta?

Because:

- We have a superb heat exchanger cooled engine range especially engineered for the yachtsman and work boats at an affordable price, with a 3 year 'self service' warranty.
- With our Dealer network and dedicated seagoing team, we have probably installed a Beta engine in a yacht similar to yours. Ask for details!
- Special engine feet option - designed and manufactured to suit your engine bearers.
- Easy maintenance with mounted sump pump and standard/optional polyvee belt and pulley drive transmission with our high output alternators.
- Our Small engine range is based upon the most technically advanced Kubota diesels that give you very smooth, quiet power, right through the speed range.
- Low carbon foot print - these clean engines meet all current and projected exhaust emission regulations - both **RCD** (Recreational Craft Directive 94/25/EC as amended by 2003/44/EC) and **EPA** (U.S Environmental Protection Agency) exhaust emission compliance.
- Beta Engines are built in Gloucestershire, U.K.
- See our website for many details:
www.betamarine.co.uk

Beta's Gloucester manufacturing facility

Seagoing Specifications

Beta Marine's Seagoing engines are:

- Heat Exchanger cooled, indirect injection, naturally aspirated marine diesel engines based on Kubota.
- Multi cylinder with high inertia flywheel for smooth running.
- Three vortex combustion for quiet running, low emissions and excellent fuel consumption.
- Quiet gear driven camshaft for engine reliability and easy servicing – no timing chains or tooth belts to replace.
- Water cooled exhaust manifold.
- Battery charging alternator 40/65 amps - giving full power at cruising speed with 12 volt electric starting as standard.
- Heater plugs for cold start below 5°C.
- Standard 'ABV' Control Panel.
- Heavy duty feet and flexible mountings.
- Technodrive, or PRM, or ZF gearbox with 2:1 reduction ratio as standard. Output rotation is clockwise in ahead, viewed from gearbox end.
- Fuel filter and mechanical fuel lift pump.
- Lubricating oil filter and sump drain pump.
- 'Morse' type engine speed and gearbox control cable support and end fittings.
- Installation angles up to 15° maximum when static, and 25° when heeling.

Seagoing Options

- A, ABVW, B and C Control panel options with gauges and alarms.
 - Down angle and Vee drive gearbox options.
 - Shallow sump.
 - Special engine feet for your installation.
 - Calorifier connections for hot water systems.
 - Larger 70/120 amp battery charging alternators and second 70 amp.
- Many more – see our price list!



Beta 10

2 Cylinders - 479cc - 10hp max at 3,000 rev/min - 89Kg

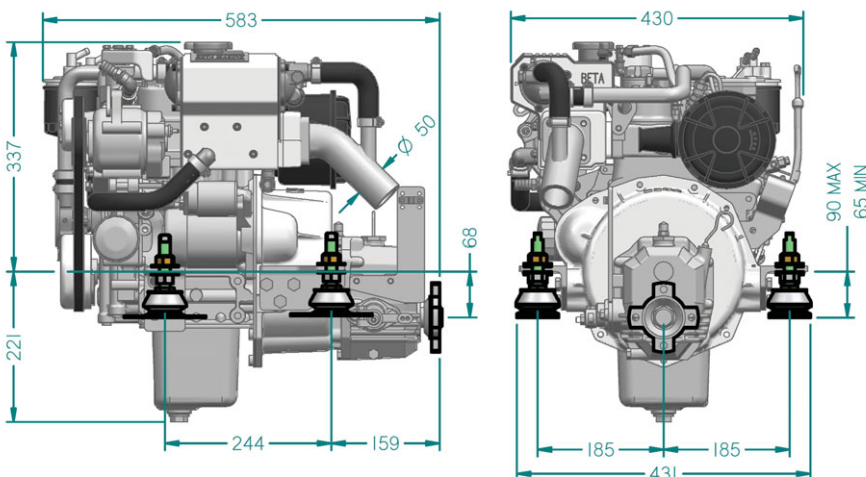
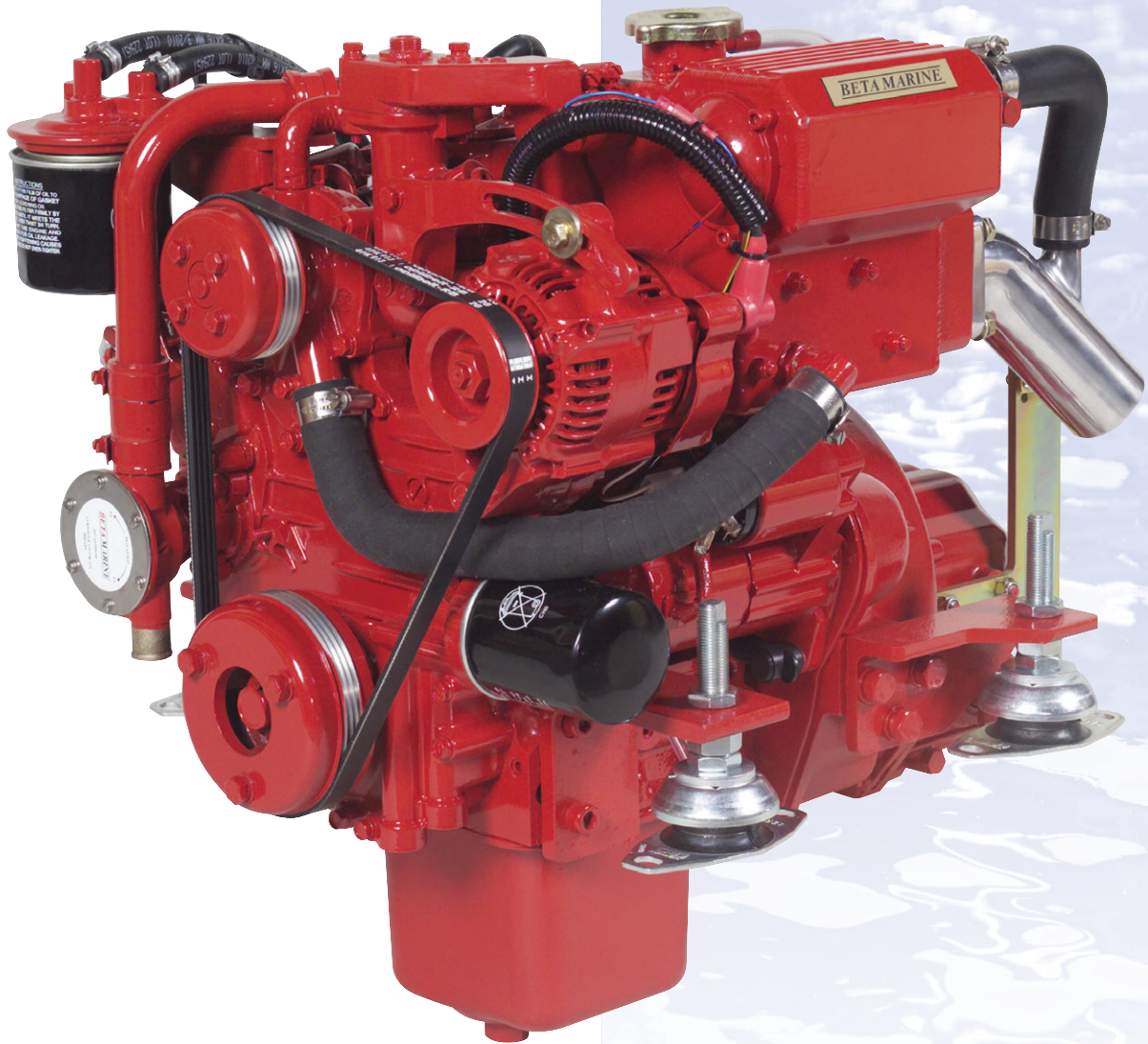

These are typical dimensions: please ask Beta Marine for an accurate drawing if required

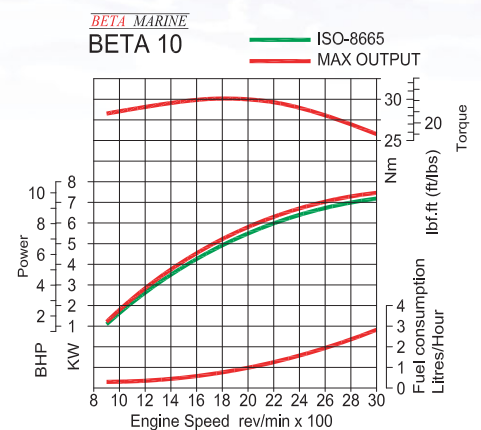

Fuel Consumption
Based on theoretical propeller loading
- matched at full speed

Beta 14

2 Cylinders - 479cc - 13.5hp max at 3,600 rev/min - 90Kg

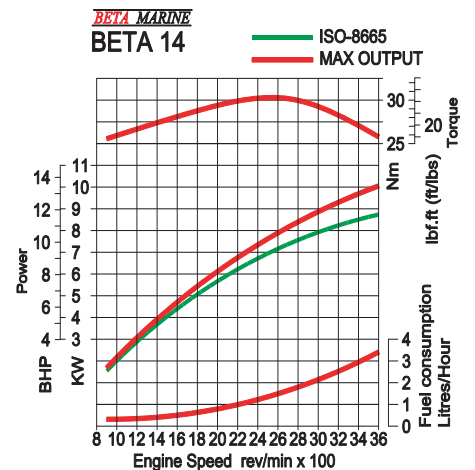
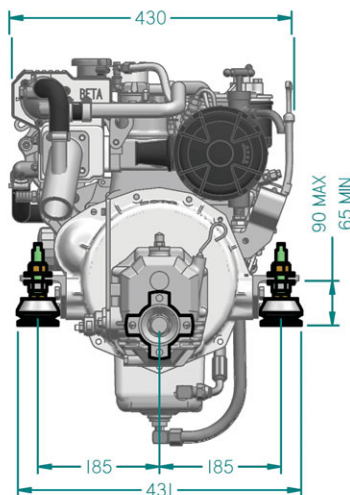
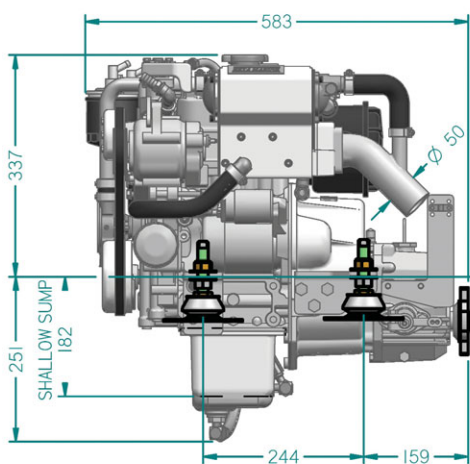
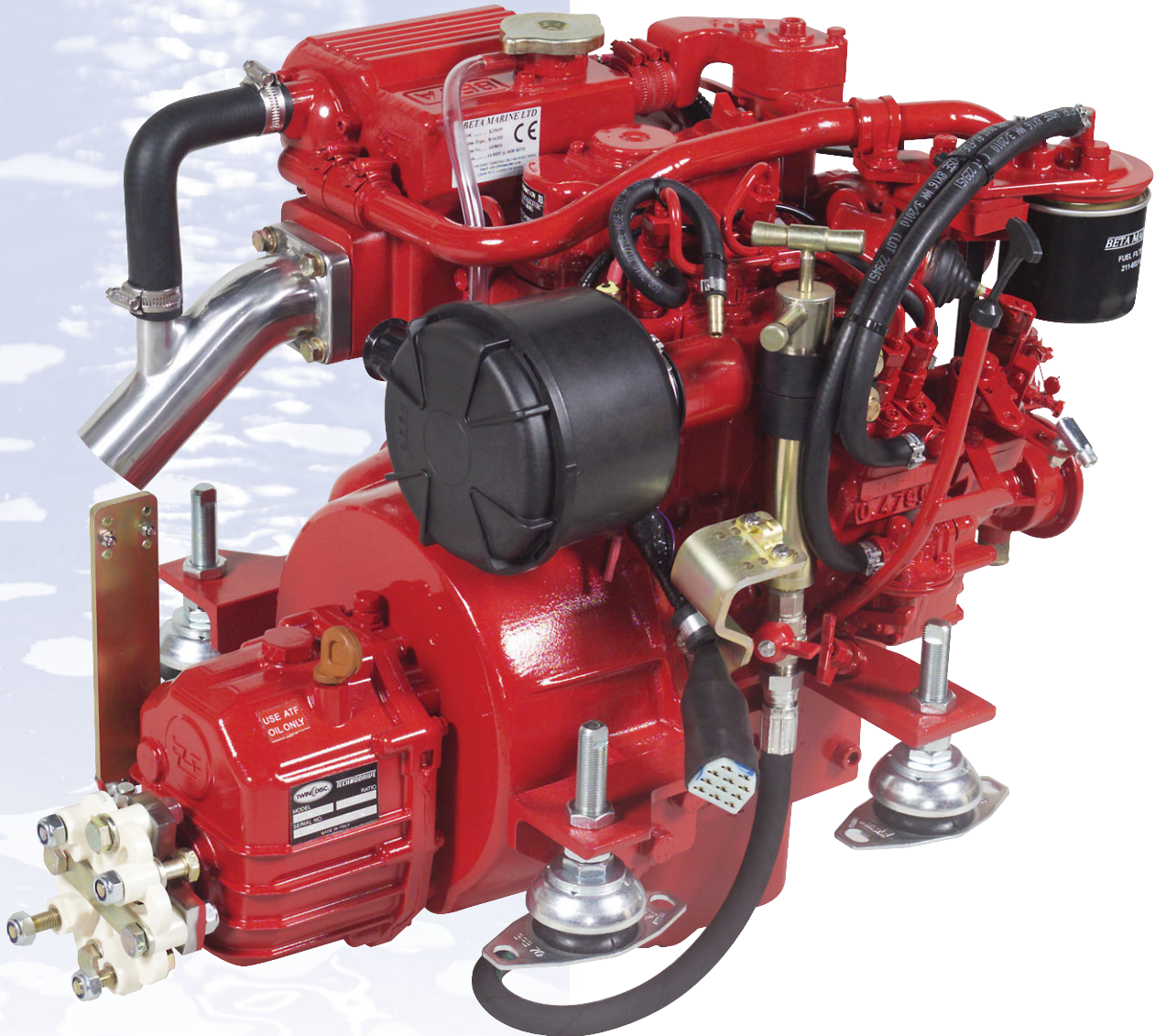

These are typical dimensions: please ask Beta Marine for an accurate drawing if required

Fuel Consumption
Based on theoretical propeller loading
- matched at full speed

Beta 16

2 Cylinders - 599cc - 16hp max at 3,600 rev/min - 95Kg



Engine shown with optional high-rise injection bend

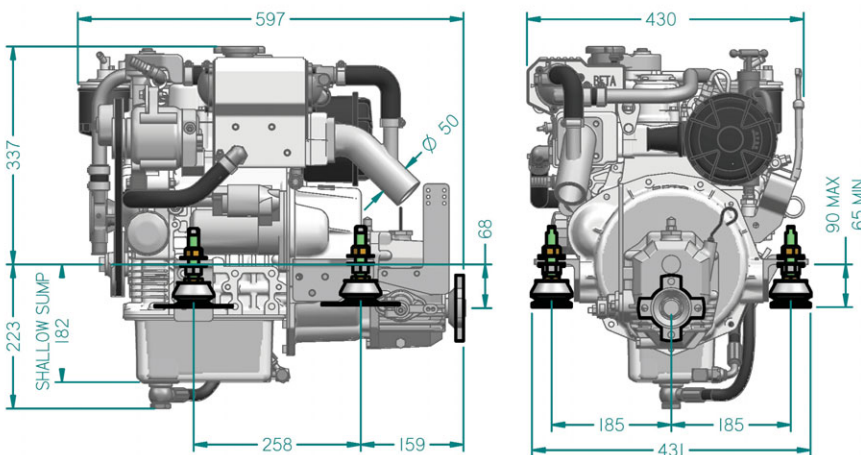

These are typical dimensions: please ask Beta Marine for an accurate drawing if required

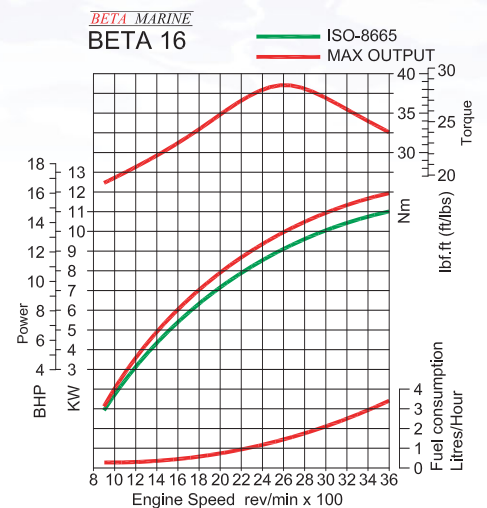

Fuel Consumption
Based on theoretical propeller loading
- matched at full speed

Beta 20

3 Cylinders - 719cc - 20hp max at 3,600 rev/min - 104Kg

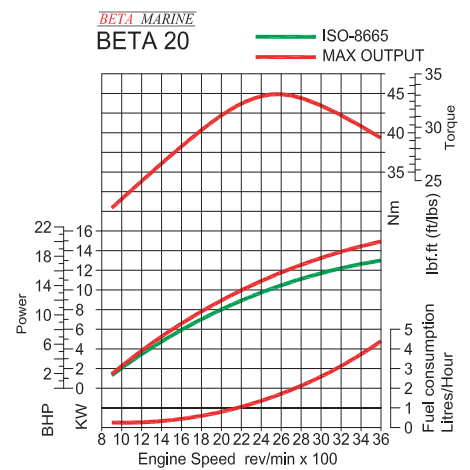
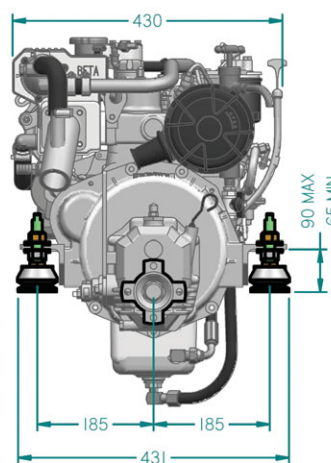
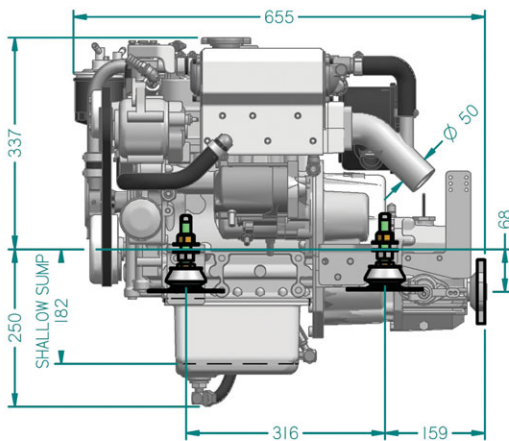
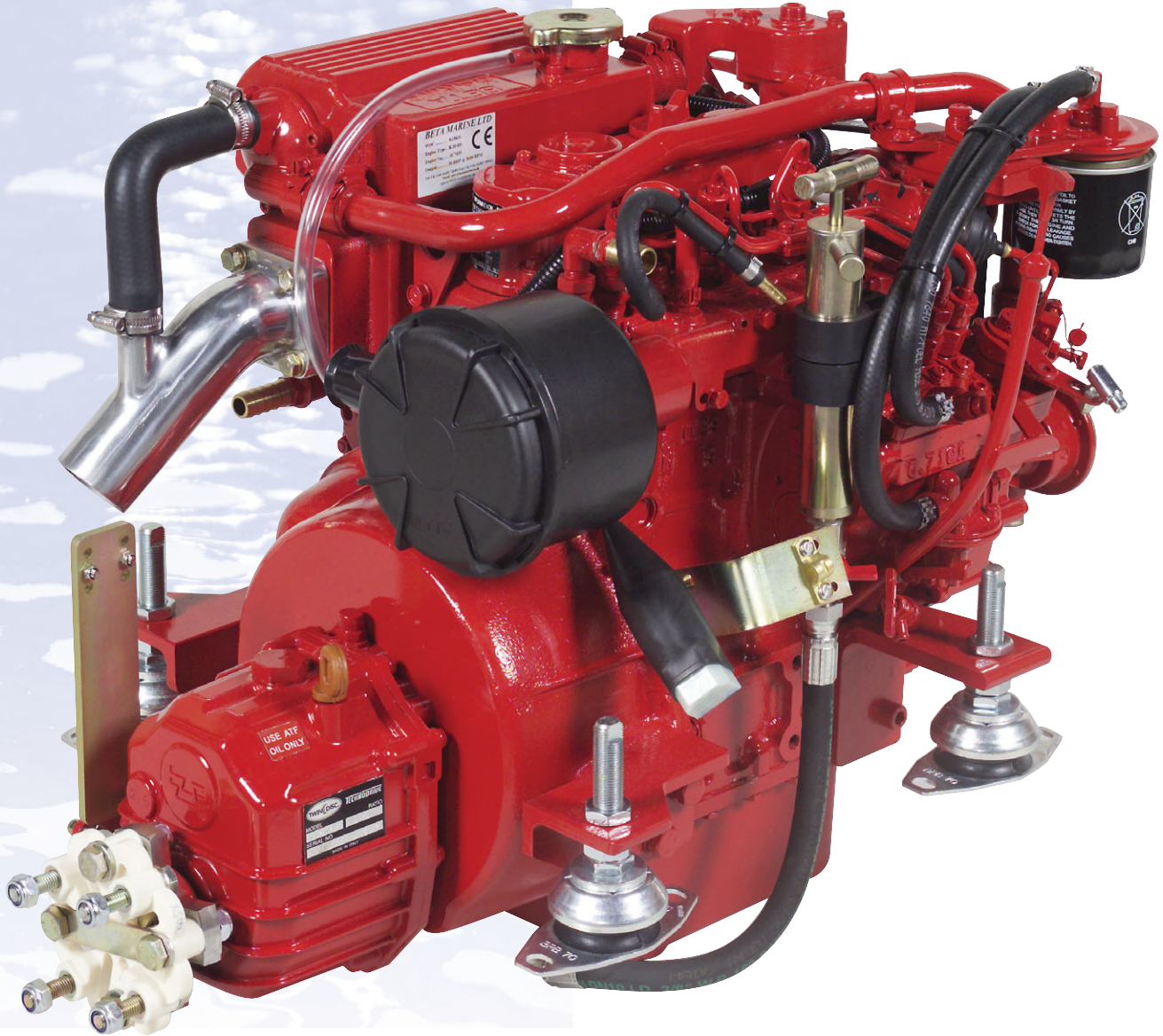

These are typical dimensions: please ask Beta Marine for an accurate drawing if required

Fuel Consumption
 Based on theoretical propeller loading
 - matched at full speed

Beta 25

3 Cylinders - 898cc - 25hp max at 3,600 rev/min - 113Kg

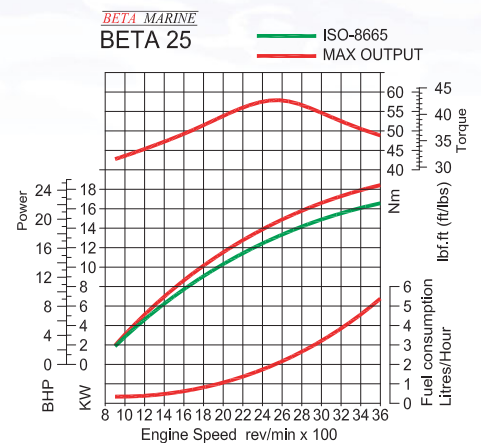
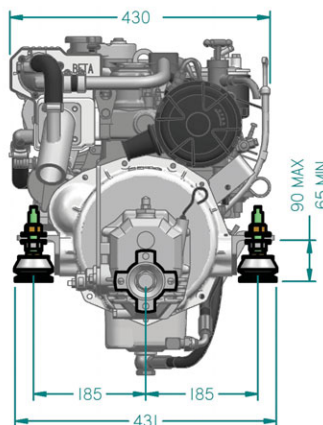
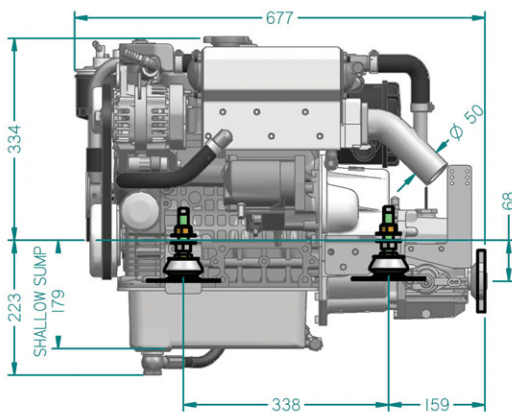
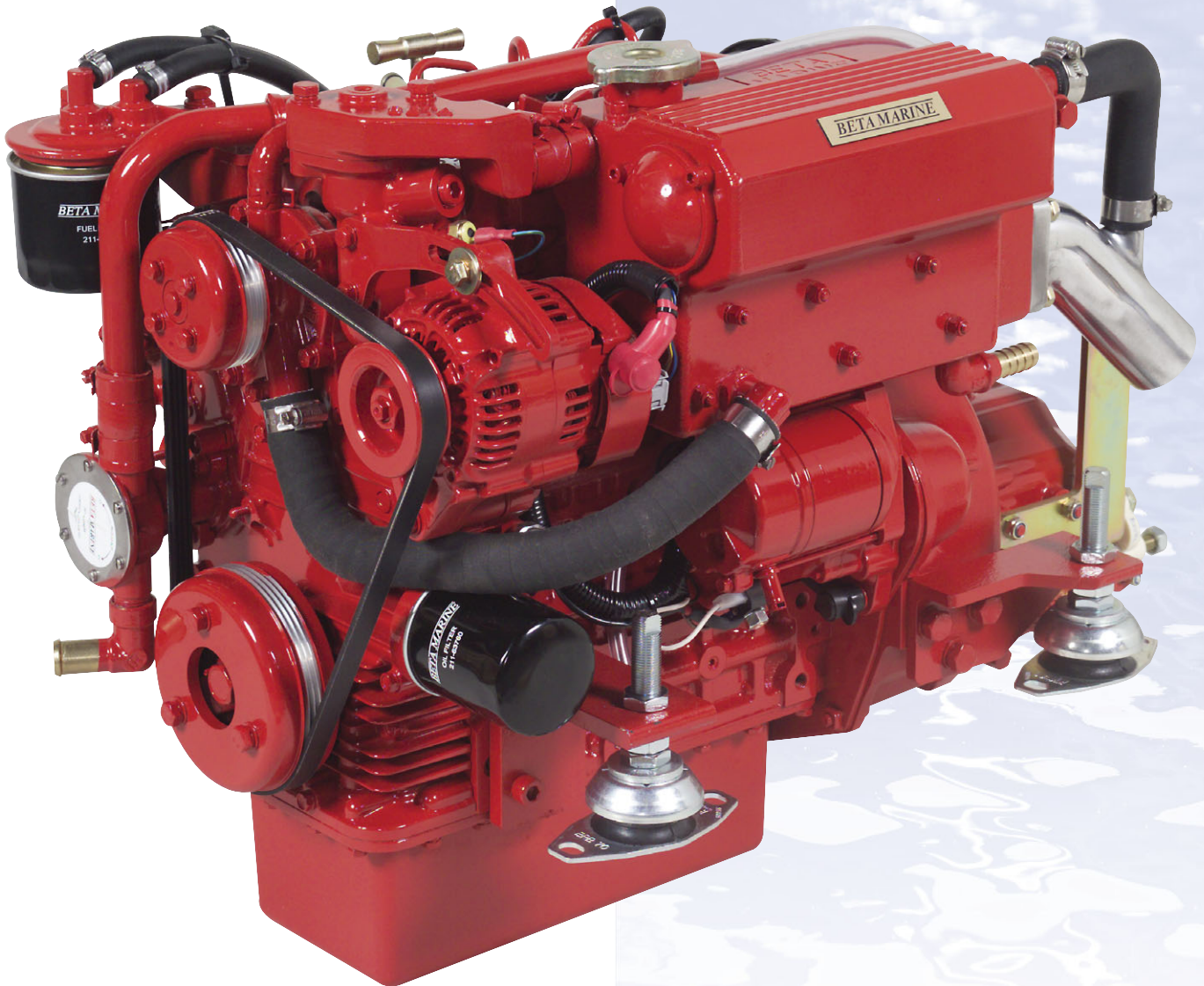

These are typical dimensions: please ask Beta Marine for an accurate drawing if required

Fuel Consumption
Based on theoretical propeller loading
- matched at full speed

Beta 30

3 Cylinders - 1123cc - 30hp max at 3,600 rev/min - 139Kg

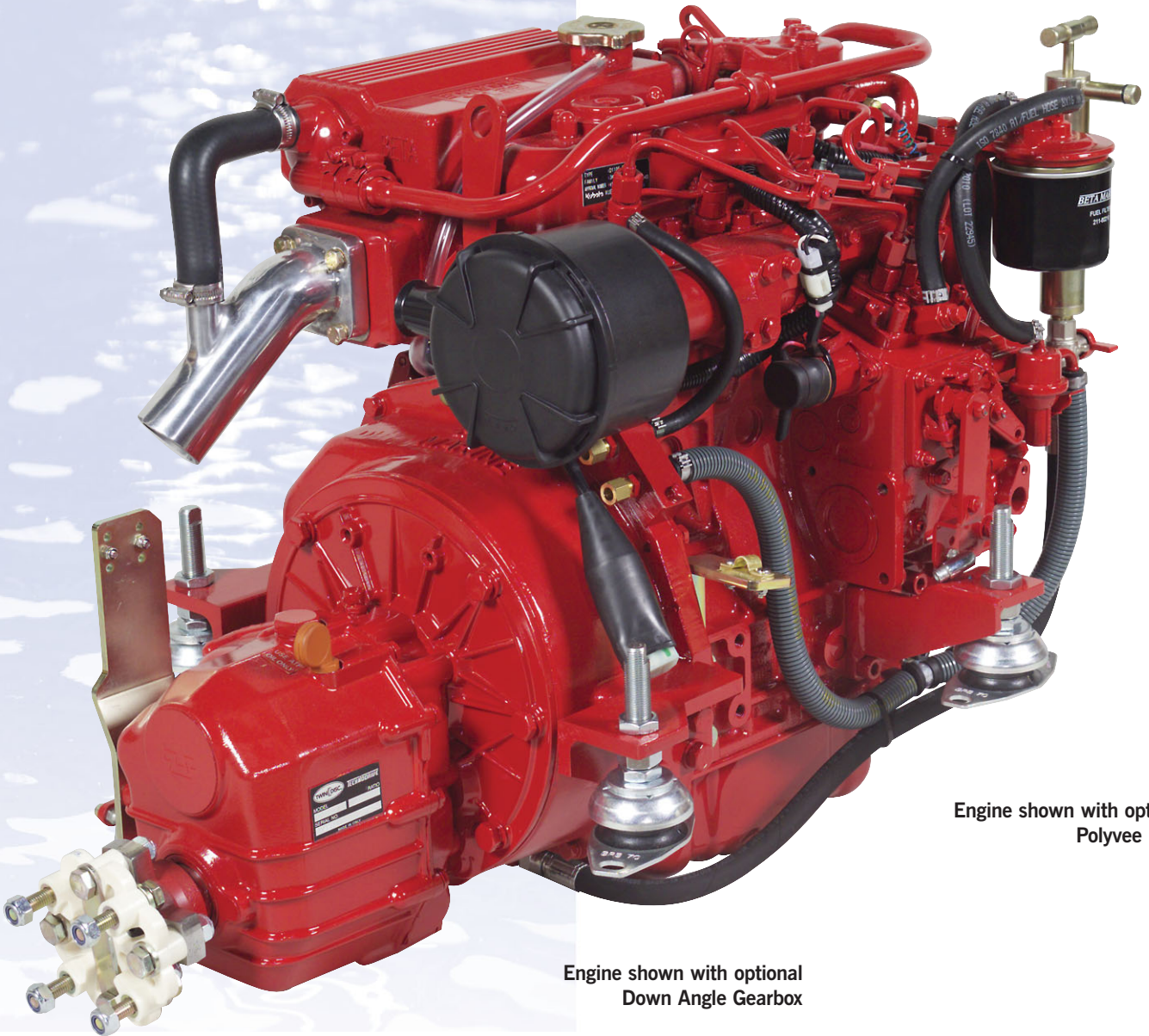

Engine shown with optional Polyvee Drive

Engine shown with optional Down Angle Gearbox

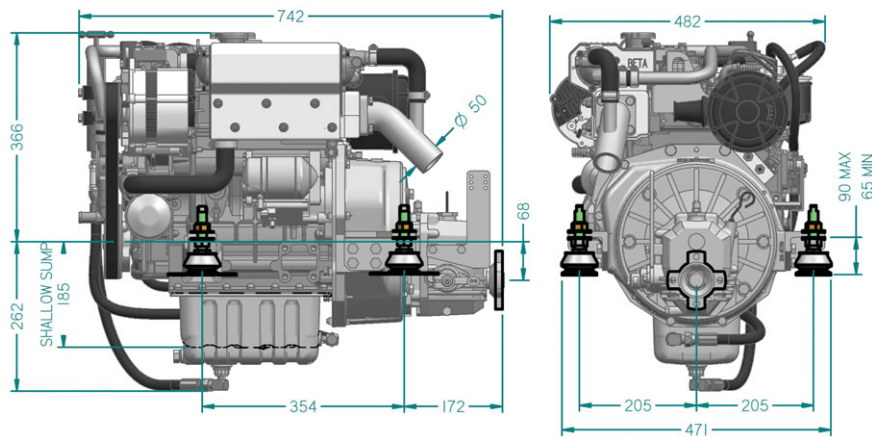

These are typical dimensions: please ask Beta Marine for an accurate drawing if required

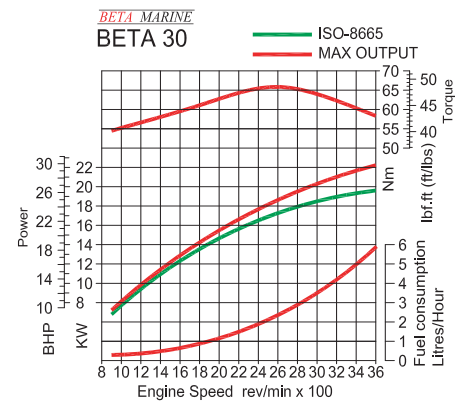

Fuel Consumption
Based on theoretical propeller loading
- matched at full speed

Beta 35

4 Cylinders - 1498cc - 35hp max at 2,800 rev/min - 168Kg

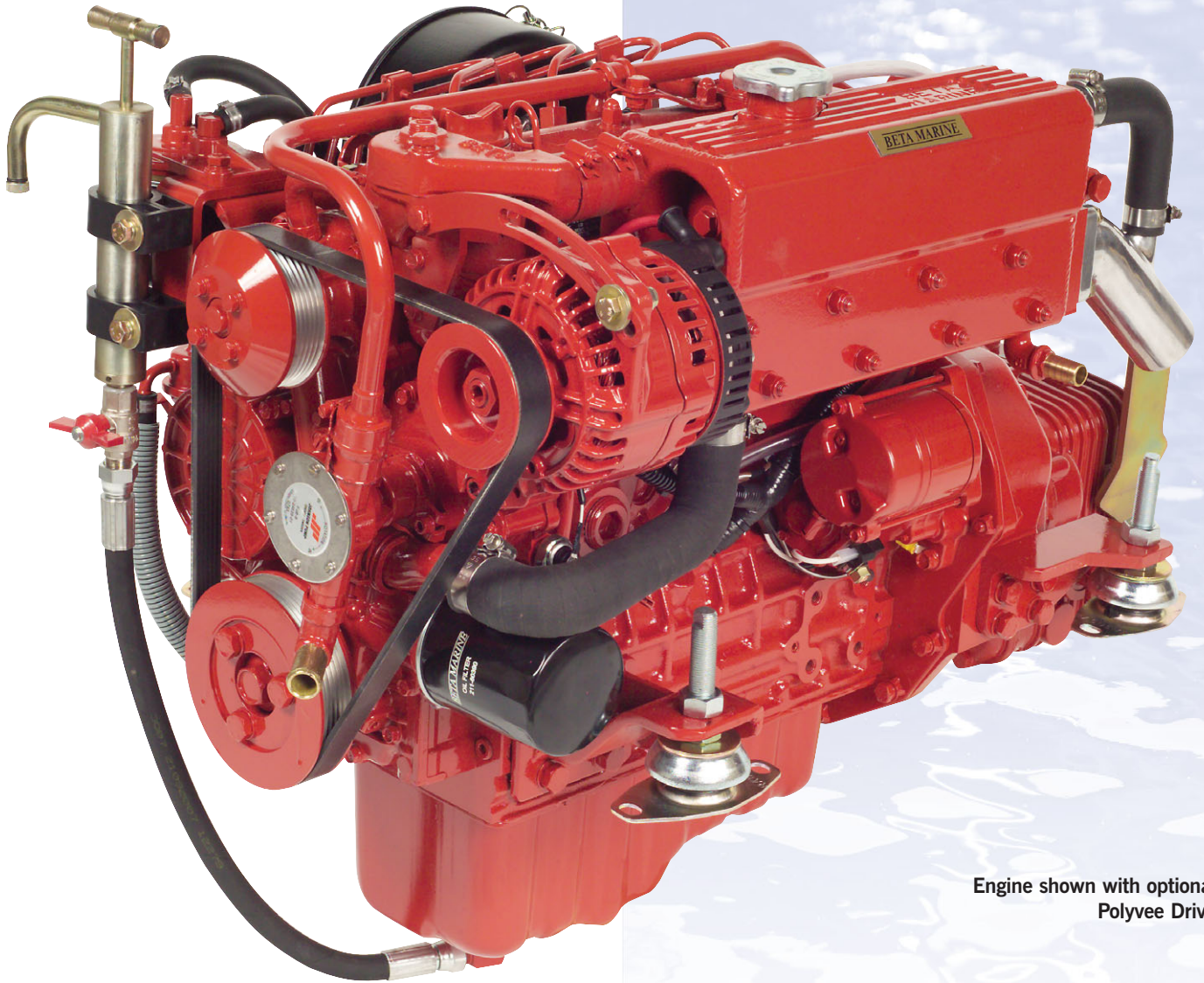

Engine shown with optional Polyvee Drive

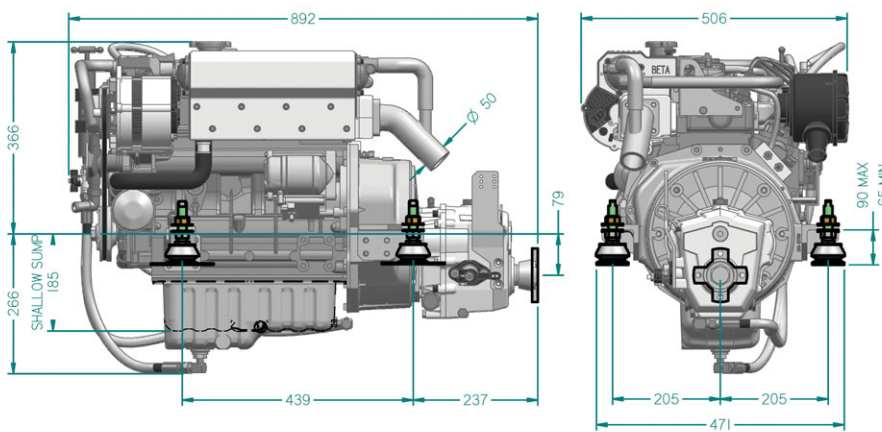

These are typical dimensions: please ask Beta Marine for an accurate drawing if required

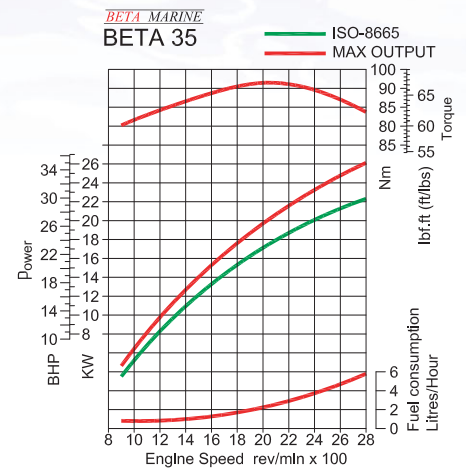

Fuel Consumption
Based on theoretical propeller loading
- matched at full speed

Beta 38

4 Cylinders - 1498cc - 38hp max at 3,600 rev/min - 168Kg

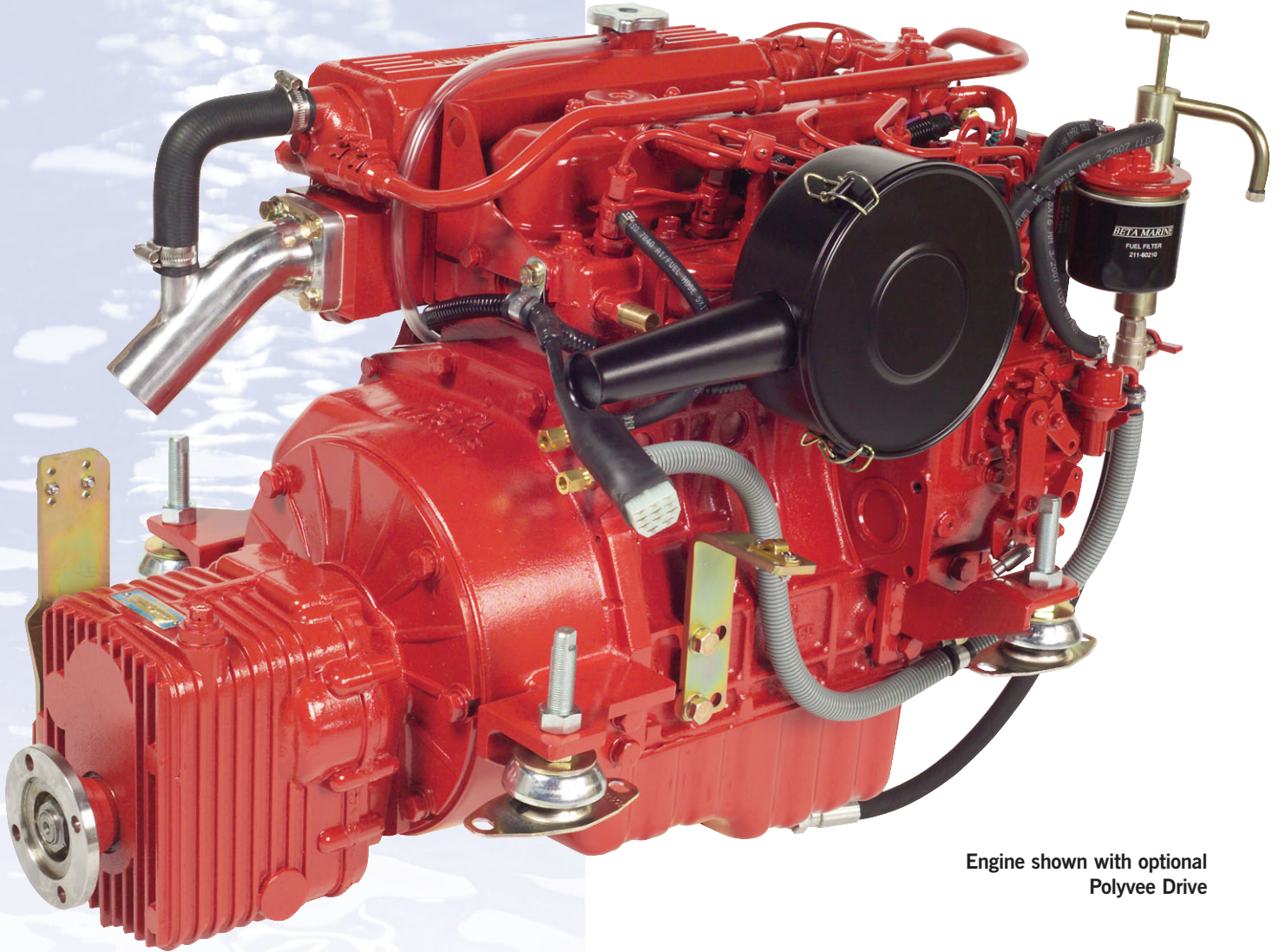

Engine shown with optional Polyvee Drive

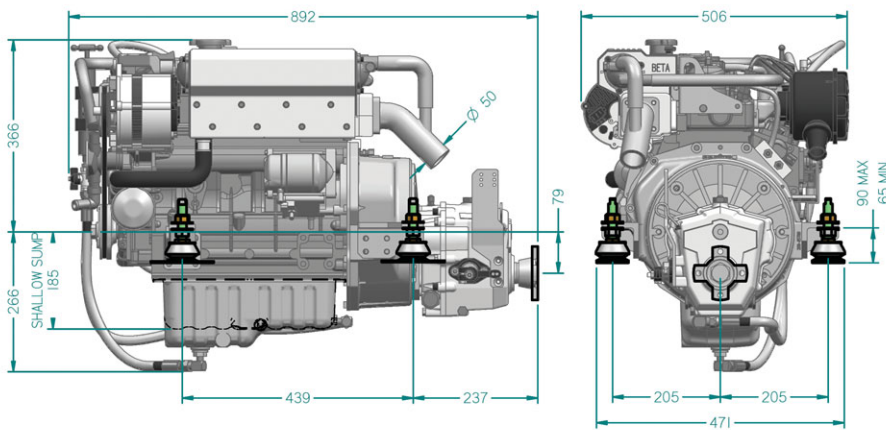

These are typical dimensions: please ask Beta Marine for an accurate drawing if required

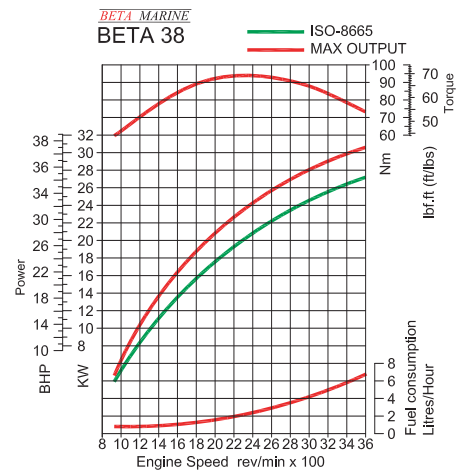

Fuel Consumption
Based on theoretical propeller loading
- matched at full speed

Control Panels

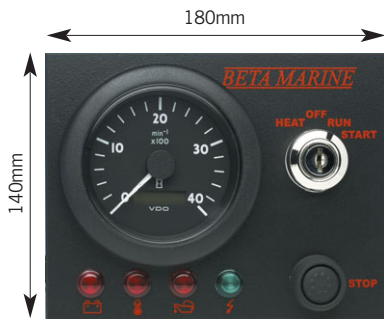

Standard 'ABV' Control Panel

Tachometer with running hour recorder, keystart switch, push button stop, green light for 'power on', red warning lights and audible alarm for: low oil pressure, high water temperature, domestic and engine alternators 'no charge'; 3m interconnection cable with multi pin plug connector.



Optional 'A' Control Panel

Keystart switch, push button stop, green light for 'power on', red warning lights and audible alarm for: low oil pressure, high water temperature, domestic and engine alternators 'no charge'; 3m interconnection cable with multi pin plug connector.



Optional 'ABVW' Control Panel

Tachometer with running hour recorder, waterproof push buttons for heat/start/stop, green light for 'power on', red warning lights and audible alarm for: low oil pressure, high water temperature, domestic and engine alternators 'no charge'; 3m interconnection cable with multi pin plug connector.



Optional 'B' Control Panel

Tachometer with running hour recorder, water temperature gauge, keystart switch, push button stop, green light for 'power on', red warning lights and audible alarm for: low oil pressure, high water temperature, domestic and engine alternators 'no charge'; 3m interconnection cable with multi pin plug connector.



Optional 'C' Control Panel

Tachometer with running hour recorder, oil pressure and water temperature gauges, voltmeter, keystart switch, push button stop, green light for 'power on', red warning lights and audible alarm for: low oil pressure, high water temperature, domestic and engine alternators 'no charge'; 3m interconnection cable with multi pin plug connector.

Re-Engining? - Special Feet

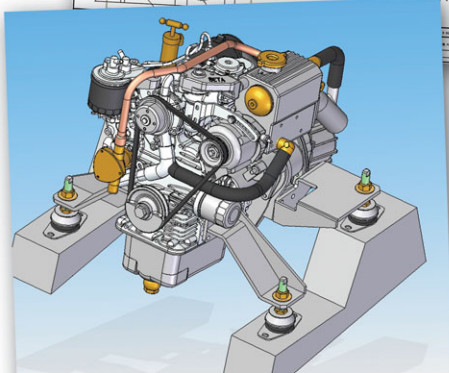
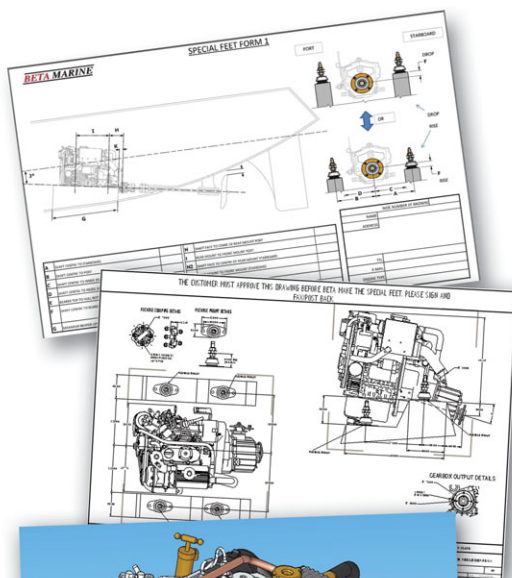

Are you replacing an old engine?

Beta engines have been fitted into thousands of yachts around the world with our standard engine feet; but where necessary we also offer our unique service of designing and manufacturing "Special Engine Feet" so that our engine just drops onto your existing engine bearers.

We have made hundreds of "Special Feet" over the years and in many cases can substantially reduce the time and installation costs.

The system works like this: we have a standard drawing where you just fill in the measurements of your existing engine bearers and propeller shaft position; we then prepare a finalised drawing for you to sign-off for us to manufacture your special feet. We then manufacture, fit and paint them so that your engine arrives ready to 'drop in'.

BETA MARINE

The Yachtman's Choice...

- Advanced engineering giving very low emissions
- Compact and quiet - they run like sewing machines
- National and International Dealer support
- Large 70 and 120 amp alternator options
- Special feet option - manufactured to suit your installation
- Heat exchanger cooled



Saildrives

Beta 1450, Beta 1650, Beta 2050,
Beta 2550, Beta 3050, Beta 3550,
Beta 3850, Beta 4350, Beta 5050
& Beta 6050



Beta 10
& Beta 14



Beta 16



Beta 20



Beta 25



Beta 30

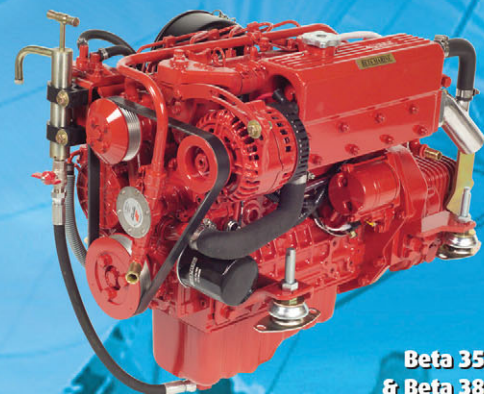

Beta 35
& Beta 38

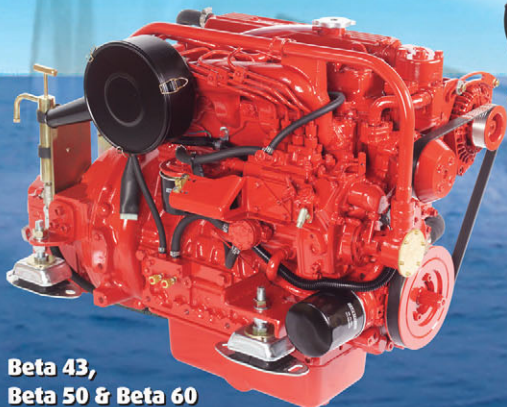

Beta 43,
Beta 50 & Beta 60



Beta 75,
Beta 90 & Beta 105

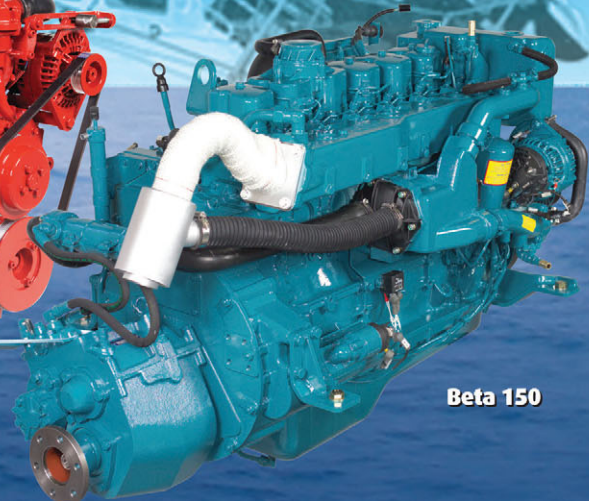

Beta 150